

DEPARTMENT OF THE ARMY TECHNICAL MANUAL

---

TECHNICAL MANUAL  
OPERATOR AND ORGANIZATIONAL  
MAINTENANCE MANUAL  
TRUCK, LIFT, FORK, POWER SHIFT G.E.D.,  
6,000 LB  
CAPACITY, SRT. 180 IN. LIFT  
(ALLIS CHALMERS MODEL F60-24PS-180)  
(ARMY MODEL MHE 212)  
FSN 3930-489-0263

---

HEADQUARTERS, DEPARTMENT OF THE ARMY

MARCH 1971

This reprint includes all changes in effect at the time of publication; changes 1 through 3.

**WARNING**

**HAZARDOUS CONDITIONS.**

are present during servicing of this equipment.

**DEATH**

or serious burns may result if personnel fail to observe safety precautions. When servicing the battery, do not smoke or use flame in the vicinity. Batteries generate hydrogen, a highly explosive gas.

**WARNING**

**COMBUSTIBLE FUEL**

is used for operation of this equipment.

**DEATH**

or serious burns may result if personnel fail to observe safety precautions. Do not fill fuel tank while engine is running. Provide metallic contact between the fuel container and fuel tank to prevent a static spark from igniting fuel. Wipe or flush any spillage. Make sure fire extinguisher is on truck.

**WARNING**

**HIGH TIERING, TRAVELING, AND LIFTING**

with this equipment.

**DEATH**

or serious injury may result if personnel fail to observe safety precautions. Position elevated load with a slight back tilt of mast over loading spot, then tilt mast forward to stack.

Use caution when approaching doorways, aisles, intersections or workers. Avoid sudden starting and stopping. Reduce speed on turns. Know rated capacity of truck and do not overload it. Descend ramps in reverse. Block at least two wheels when parked on incline.

**WARNING**

**PRESSURIZED COOLANT**

is present in a warm or overheated engine.

**DEATH**

or serious burns may result if personnel fail to observe safety precautions. Do not remove the radiator cap from an overheated radiator; stop and allow radiator to cool before removing cap to avoid injury by scalding.

CHANGE  
NO. 4

**TM 10-3930-624-12**  
**C 4**  
HEADQUARTERS  
DEPARTMENT OF THE ARMY  
Washington, D.C., 12 November 1989

**Operator and Organizational Maintenance Manual**

**TRUCK, LIFT, FORK: POWER SHIFT G.E.D.,  
6,000 LB CAPACITY, SRT, 180 IN. LIFT  
(ALLIS CHALMERS MODEL F60-24PS-180)  
(ARMY MODEL MHE-212)  
NSN 3930-00-489-0263**

TM 10-3930-624-12, 2 March 1971, is changed as follows:

The manual title is changed to read as shown above.

*Page i.*

The manual title is changed to read as shown above.

Chapter 3. Add "Section VIII. Maintenance of the brakes, paragraph 3-14, page 3-4".

*Page iii.*

Add illustration number "figure 3-4 Hand brake adjustment, page 3-4".

Add illustration number "fig 4-52.1, Inching pedal mechanical adjustment, page 4-43".

Add illustration number "fig 4-52.2, Inching pedal hydraulic adjustment, page 4-43".

*Page 1-1.*

Paragraph 1-1b. Change "TM 750-244-3 (Procedures for Destruction of Equipment to Prevent Enemy use)" to "TM 750-244-6 (Procedures for Destruction of Tank-Automotive Equipment to Prevent Enemy Use)".

Paragraph 1-2 is superseded as follows:

**1-2. Maintenance Forms, Records, and Reports**

Maintenance forms, records, and reports which are to be used by maintenance personnel at all maintenance levels are listed in and prescribed by DA Pam 738-750.

Paragraph 1-4 is superseded as follows:

**1-4. Reporting Errors and Recommending Improvements.**

You can help improve this manual. If you find any mistakes or if you know of a way to improve the procedures, please let us know. Mail your letter or DA Form 2028 (Recommended Changes to Publications and Blank Forms) direct to: Commander, U.S. Army Tank-Automotive Command, AMSTA-MB, Warren, MI 48397-5000. A reply will be furnished to you.

*Page 3-2.* Paragraph 3-2*i* is rescinded.

*Page 3-3.* Table 3-1 is changed as follows:

In the Procedure column for sequence number 4, change to read as follows: "Check electrolyte level weekly. Report low electrolyte level to organizational maintenance. Check for loose or damaged battery cables. Report loose or damaged battery cables to organizational maintenance."

Table 3-1 is changed as follows:

Operator's Maintenance Category			Item to be inspected	Daily Schedule (or weekly)	Paragraph reference
Interval and sequence number					
Before operation	During operation	After operation		Procedure	
6.1	...	....	Fan belt .....	Inspect fan belt for looseness or damage. Proper tension is 1/2 inch deflection, midway between fan pulley and the alternator pulley. Report all damage and deficiencies to organizational maintenance.	
12.1	...	...	Tires .....	Check for embedded glass and metal, cuts, gouges, and other damage. Report all damage to organizational maintenance.	

Page 3-4. Add the following: "Section VIII. MAINTENANCE OF THE BRAKES".

**3-14. General**

The parking brake is a dual shoe mechanical brake, mounted on the drive shaft, and can be used either as a parking brake or an emergency brake. The brake shoes are actuated through a cable by an adjustable over-center type lever mounted on the left-hand cowl panel. A service brake is mounted on each of the drive wheels. The service brakes are operated by hydraulic pressure. The brake drum rotates on the end of the drive axle and the shoe assemblies are mounted on the backing plate.

**3-15. Parking Brake Adjustment**

- a. Set the hand brake lever in the fully-released position.
- b. Remove the setscrew that locks the adjusting knob in position as illustrated in figure 3-4.
- c. Turn the adjusting knob in a clockwise direction one or two turns. Check the adjustment by engaging the brake.
- d. Repeat step c if necessary; otherwise install the setscrew in the adjusting knob to prevent loss of adjustment.

- (1) Check the level of electrolyte weekly. Add distilled water if necessary.

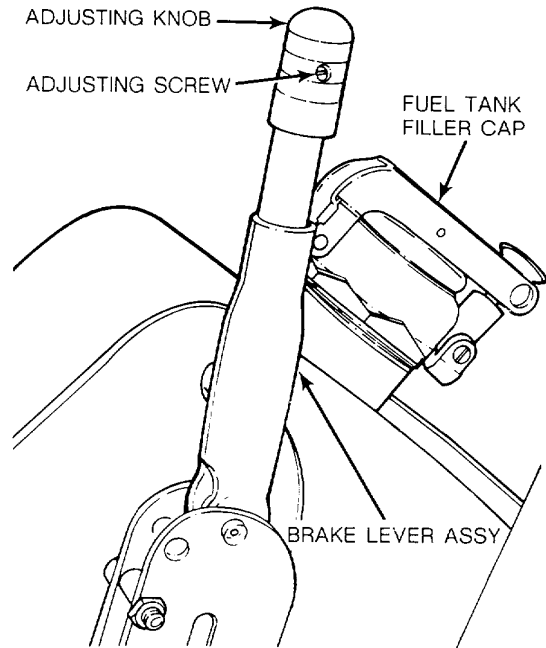

TA501592 ■

Page 4-2. Paragraph 4-5. Delete "(When printed)".

Page 4-34. Paragraph 4-39i is added as follows:

- i. *Battery Service.*

**Note.** Overfilling the battery can cause poor performance or early failure due to loss of electrolyte.

Figure 3-4. Hand brake adjustment.

- (2) Keep the top of the battery clean.
- (3) Refer to TM 9-6140-200-14 for more specific servicing information.

Page 4-41.

Paragraph 4-50c is superseded as follows:

c. *Parking Brake Adjustment.* Refer to paragraph 3-15.

Figure 4-48 is rescinded.

Page 4-43. Paragraph 4-53.1 is added as follows:

#### 4-53.1. Pedal, Brake and Inching

a. Removal.

(1) Remove the floor plate and toe plate (para 4-72).

(2) Disconnect the master cylinder clevis pin. Remove the pedal springs and the brake pedal stop.

(3) Remove the setscrews holding the shaft in position. Install a 2 inch long capscrew in the end of the pedal shaft.

(4) Pressing against the capscrew, press the shaft out of the steering column mounting bracket into the opposite bracket and remove the capscrew.

(5) Loosen the bracket capscrews and lower the assembly until the shaft can be removed from the pedals. Remove the pedals from the truck.

b. *Installation.*

(1) Position the pedals in the shaft. Raise the shaft and pedal assembly into alignment with the hole in the steering column mounting bracket and push the shaft into the hole.

(2) Insert the 2 inch long capscrew into the end of the shaft and pull the shaft out far enough to locate the setscrew holes. Align them with the setscrew

holes in the mounting brackets, push in the shaft, and install the setscrews. Remove the capscrew and tighten the mounting bracket.

(3) Install the brake pedal stop and the pedal springs. Connect the master cylinder clevis pin.

(4) Make any necessary adjustments (subpara c).

(5) Install the toe plate and floor plate (para 4-72).

c. *Adjustment.*

(1) Mechanical adjustment. (fig. 4-52.1.)

**Caution: Ensure that the inching plunger is completely bottomed before making any adjustments. Be sure that the inching pedal stop prevents the inching plunger from piercing the back of the control valve.**

(a) With the brake pedal in the normal position, set the inching pedal stop to allow a 1/16-1/4 inch gap between the pickup lug and brake pedal.

(b) Install the return spring (normal length 10 inch). Tighten the spring until it is 11-11 1/4 inch long.

(c) Position the inching spring against the plunger so that the deflection is 3/32-1/8 inch

(d) Raise the drive wheels off the floor, start the engine and operate at high idle, and shift the transmission into forward or reverse gear. The inching valve plunger must not move forward.

(e) Lower the wheels to the ground, engage the brakes, and place the transmission in gear. The engine should approach a stall. Shut down the engine.

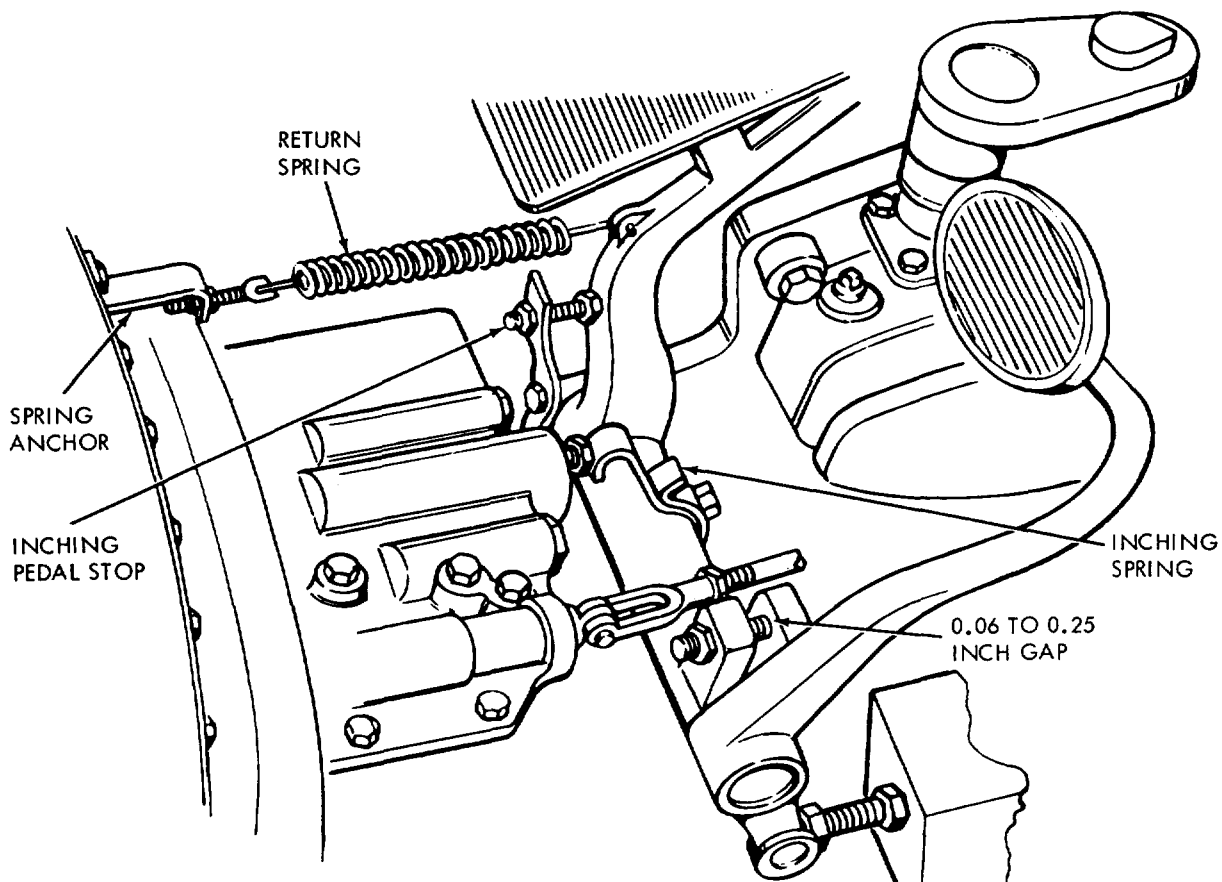

TA501857

Figure 4-52.1. Inching pedal mechanical adjustment.

(2) Hydraulic adjustment. (fig. 4-52.2.)

**Note. Do not perform hydraulic adjustments until the mechanical adjustments are correct.**

(a) Install a 160 or 300 psi pressure gage at the pressure port of the power shift control cover.

(b) Depress the brake pedal until the brake shoes engage the drum. A slight resistance will be felt in pedal movement.

(c) Place a wedge between the brake return stop and the pedal lug to fix the position of engagement.

(d) Engage the parking brake.

(e) Start the engine and operate at low idle (500 to 600 rpm). Place the transmission in

neutral and keep the seat deck down. Depress the inching pedal until the pressure gage reads 6 to 10 psi.

(f) Set the adjusting screw to contact the brake pedal and lock.

(g) Operate the engine at high idle speed. Remove the wedge and compress the inching pedal spring to  $3/32$ - $1/8$  inch. Pressure gage should indicate 100-160 psi. Pull the inching pedal forward and ensure that the pressure reading does not increase. Shut down the engine.

(h) Loosen the inching spring mounting capscrew and readjust the spring to a  $3/32$ - $1/8$  inch deflection. Tighten the capscrew. Check for free oscillation of the inching spring.

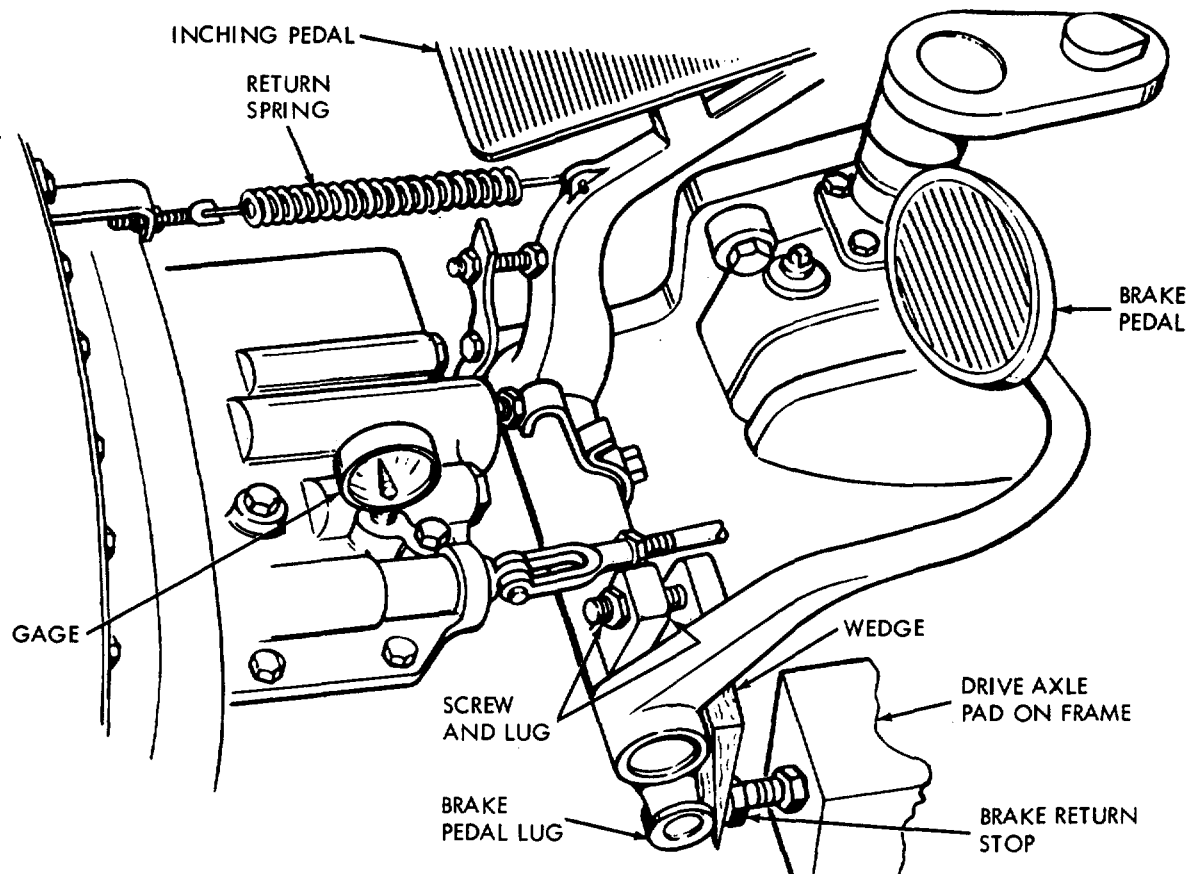

TA501858 ■

Figure 4-52.2. Inching pedal hydraulic adjustment.

Page 4-48. Following 4-61a(6), subparagraphs 4-61b and 4-61c are added as follows:

*b. Removal.*

- (1) Place the mast in forward position. Hold the mast in position with a chain.
- (2) Remove the cotter key and pin from the tilt cylinder.
- (3) Remove the toe plate and floor plate (para 4-72).
- (4) Disconnect hydraulic lines at the tilt cylinder. Cap or plug openings.
- (5) Remove the capscrew and pin retainer from the tilt cylinder mounting bracket in the frame. Insert a drift into the tilt cylinder pin and remove the pin. Remove the tilt cylinder.

*c. Installation.* Install the tilt cylinder in the reverse order of removal. Start the engine and operate the mast through several complete cycles and check for hydraulic leaks. Make sure the tilt cylinders bottom simultaneously.

Page A-1.

Paragraph A-1. Change "TB 5-4200-200-10" to "TB 5-4200-200-100".

Paragraph A-3. Change "TM 9-213" to "TM 43-0139".

Paragraph A-5.

Change "TM 38-750" to "DA Pam 738-750".

Add "TM 10-3930-624-20P, Organizational Maintenance Repair Parts and Special Tools Lists, Truck, Lift, Fork: Power Shift G.E.D., 6,000 LB Capacity, SRT, 180 In. Lift (Allis-Chalmers Model F60-24PS-180) (Army Model MHE-212) NSN 3930-00-489-0263".

Change "TM 10-3930-624-35P" and its title to "TM 103930-624-34P, Direct Support and General Support Maintenance Repair Parts and Special Tools Lists (Including Depot Maintenance Repair Parts and Special Tools Lists), Truck, Lift, Fork: Power Shift G.E.D., 6,000 LB Capacity, SRT, 180 In. Lift (Allis-

Chalmers Model F60-24PS-180) (Army Model MHE-212) NSN 3930-00-489-0263".

Paragraph A-7. Change "TM 750-244-3" and its title to "TM 750-244-6, Procedures for Destruction of

Tank-Automotive Equipment to Prevent Enemy Use".

Page C-1. Appendix C is superseded as follows:

## APPENDIX C MAINTENANCE ALLOCATION CHART

---

### Section I. INTRODUCTION

#### C-1. General

a. This section provides a general explanation of all maintenance and repair functions authorized at the various maintenance levels.

b. The Maintenance Allocation Chart (MAC) in Section II designates overall authority and responsibility for the performance of maintenance functions on the identified end item or component. The application of the maintenance functions to the end item or component will be consistent with the capacities and capabilities of the designated maintenance levels.

c. Section III lists the tools and test equipment (both special tools and common tool sets) required for each maintenance function as referenced from Section II.

d. Section IV contains supplemental instructions and explanatory notes for a particular maintenance function.

#### C-2. Maintenance Functions

Maintenance functions will be limited to and defined as follows:

a. *Inspect.* To determine the serviceability of an item by comparing its physical, mechanical, and/or electrical characteristics with established standards through examination (e.g., by sight, sound, or feel).

b. *Test.* To verify serviceability by measuring the mechanical, pneumatic, hydraulic, or electrical characteristics of an item and comparing those characteristics with prescribed standards.

c. *Service.* Operations required periodically to keep an item in proper operating condition, i.e., to clean (includes decontaminate, when required), to preserve, to drain, to paint, or to replenish fuel, lubricants, chemical fluids, or gases.

d. *Adjust.* To maintain or regulate, within prescribed limits, by bringing into proper or exact position, or by setting the operating characteristics to specified parameters.

e. *Aline.* To adjust specified variable elements of an item to bring about optimum or desired performance.

f. *Calibrate.* To determine and cause corrections to be made or to be adjusted on instruments or test, measuring, and diagnostic equipments used in precision measurement. Consists of comparisons of two instruments, one of which is a certified standard of

known accuracy, to detect and adjust any discrepancy in the accuracy of the instrument being compared.

g. *Removal/Install.* To remove and install the same item when required to perform service or other maintenance functions. Install may be the act of emplacing, seating, or fixing into position a spare, repair part, or module (component or assembly) in a manner to allow the proper functioning of an equipment or system.

h. *Replace.* To remove an unserviceable item and install a serviceable counterpart in its place. "Replace" is authorized by the MAC and is shown as the third position of the SMR code.

i. *Repair.* The application of maintenance services, including fault location/troubleshooting, removal/installation, and disassembly/assembly procedures, and maintenance actions to identify troubles and restore serviceability to an item by correcting specific damage, fault, malfunction, or failure in a part, subassembly, module (component or assembly), end item, or system.

j. *Overhaul.* That maintenance effort (service/action) prescribed to restore an item to a completely serviceable/operational condition as required by maintenance standards in appropriate technical publications (i.e., DMWR). Overhaul is normally the highest degree of maintenance performed by the Army. Overhaul does not normally return an item to like new condition.

k. *Rebuild.* Consists of those services/actions necessary for the restoration of unserviceable equipment to a like new condition in accordance with original manufacturing standards. Rebuild is the highest degree of materiel maintenance applied to Army equipment. The rebuild operation includes the act of returning to zero those age measurements (hours/miles, etc.) considered in classifying Army equipment/components.

#### C-3. Explanation of Columns in the MAC, Section II

a. *Column 1, Group Number.* Column 1 lists functional group code numbers, the purpose of which is to identify maintenance significant components, assemblies,



subassemblies, and modules with the next higher assembly. End item group number shall be "00."

b. *Column 2, Component/Assembly.* Column 2 contains the names of components, assemblies, subassemblies, and modules for which maintenance is authorized.

c. *Column 3, Maintenance Function.* Column 3 lists the functions to be performed on the item listed in Column 2. For a detailed explanation of these functions, see paragraph C-2.)

d. *Column 4, Maintenance Level.* Column 4 specifies, by the listing of a work time figure in the appropriate column(s), the level of maintenance authorized to perform the function listed in Column 3. This figure represents the active time required to perform that maintenance function at the indicated level of maintenance. If the number or complexity of the tasks with listed maintenance function vary at different maintenance levels, appropriate work time is shown for each level. The work time figure represents the average time required to restore an item (assembly, subassembly, component, module, end item, or system) to a serviceable condition under end item operating conditions. This time includes preparation time (including any necessary disassembly time), troubleshooting/ fault location time, and quality assurance/quality control time in addition to the time required to perform the specific tasks identified for the maintenance functions authorized in the Maintenance Allocation Chart. The symbol

designations for the various maintenance levels are as follows:

- C ..... Operator or Crew
- O ..... Organizational Maintenance
- F ..... Direct Support Maintenance
- H ..... General Support Maintenance
- D ..... Depot Maintenance

e. *Column 5, Tools and Equipment.* Column 5 specifies, by code, those common tool sets (not individual tools) and special tools, TMDE, and support equipment required to perform the designated function.

f. *Column 6, Remarks.* This column shall, when applicable, contain a letter code, in alphabetic order, which shall be keyed to the remarks contained in Section IV

**C-4. Explanation of Columns in Tool and Test Equipment Requirements, Section III**

a. *Column 1, Reference Code.* The code recorded in Column 6, Section II.

b. *Column 2, Remarks.* This column lists information pertinent to the maintenance function being performed as indicated in the MAC, Section II.

**Section II. MAINTENANCE ALLOCATION CHART**

(1) GROUP NUMBER	(2) COMPONENT ASSEMBLY	(3) MAINTENANCE FUNCTION	(4) MAINTENANCE CATEGORY					(5) TOOLS AND EQUIPMENT	(6) REMARKS
			C	O	F	H	D		
01 0100	ENGINE Engine Assembly	Inspect Test Service Replace Repair Overhaul	0.2  0.4	1.0	8.0	12.0 28.0			
0101	Crankcase, Block, Cylinder Head Cylinder Block Cylinder Head	Replace Replace			2.5	8.0			
0102	Crankshaft	Replace				12.0			
0103	Flywheel Assembly	Replace Repair			1.0 1.0				

**Section II. MAINTENANCE ALLOCATION CHART -Continued**

(1) GROUP NUMBER	(2) COMPONENT ASSEMBLY	(3) MAINTENANCE FUNCTION	(4) MAINTENANCE CATEGORY					(5) TOOLS AND EQUIPMENT	(6) REMARKS
			C	O	F	H	D		
0104	<i>Pistons, Connecting Rods</i> Piston, Internal	Replace				4.0			
		Repair				2.0			
	Connecting Rods	Replace				4.0			
		Repair				2.0			
0105	<i>Valves, Camshafts, and Timing Systems</i> Rocker Arm Assemblies	Replace			1.2				
		Repair				1.0			
	Valve, Poppet, Engine	Adjust		0.5					
		Replace Repair			5.5 2.0				
	Gear, Helical	Replace			2.0				
	Camshaft	Replace				8.0			
0106	<i>Engine Lubrication System</i> Filter, Fluid, Pressure	Service		0.2					
		Replace		0.3					
		Repair		0.3					
	PCV Valve	Service		0.1					
		Replace		0.2					
	Pump Assembly, Oil	Replace			2.0				
		Repair			2.0				
0108	<i>Manifolds</i> Manifold, Exhaust	Replace		1.0					
		Repair		2.0					
<b>03</b>	<b>FUEL SYSTEM</b>								
0301	<i>Carburetor</i>	Adjust		0.5					
		Replace		2.0					
0302	<i>Fuel Pump</i>	Test		0.3					
		Replace		0.5					
0304	<i>Air Cleaner</i>	Service	0.2						
		Replace		0.2					
0306	<i>Tanks ,Lines, Fittings</i> Tank , Fuel	Service	0.1						
		Replace		0.4					
		Repair				1.5			

**Section II. MAINTENANCE ALLOCATION CHART -Continued**

(1) GROUP NUMBER	(2) COMPONENT ASSEMBLY	(3) MAINTENANCE FUNCTION	(4) MAINTENANCE CATEGORY					(5) TOOLS AND EQUIPMENT	(6) REMARKS
			C	O	F	H	D		
0308	<i>Engine Speed Governor</i>	Adjust Replace Repair		0.3	0.5 1.0				
0309	<i>Fuel Filters</i>	Replace Repair		0.3 0.3					
0312	<i>Accelerator, Throttle or Choke Controls</i>								
	Accelerator Pedal and Linkage	Service Adjust Replace		0.2 0.6 0.8					
	Choke Control	Replace		0.5					
<b>04</b>	<b>EXHAUST SYSTEM</b>								
0401	<i>Muffler and Pipes</i>	Replace		1.0					
<b>05</b>	<b>COOLING SYSTEM</b>								
0501	<i>Radiator</i>	Inspect Service Replace Repair	0.1 0.2	1.0 1.0		2.0			
0503	<i>Water Manifolds, Thermostats and Housing Gasket Thermostat</i>	Inspect Replace		0.1 0.5					
0504	<i>Water Pump</i>								
	Pump, Coolant, Engine	Inspect Replace		0.1 1.2					
0505	<i>Fan Assembly</i>								
	Belt	Inspect Adjust Replace	0.1	0.2 0.8					
<b>06</b>	<b>ELECTRICAL SYSTEM</b>								
0601	<i>Alternator, Engine</i>	Test Replace Repair		0.5 0.5	2.0				

**Section II. MAINTENANCE ALLOCATION CHART -Continued**

(1) GROUP NUMBER	(2) COMPONENT ASSEMBLY	(3) MAINTENANCE FUNCTION	(4) MAINTENANCE CATEGORY					(5) TOOLS AND EQUIPMENT	(6) REMARKS
			C	O	F	H	D		
0602	<i>Generator Regulator (Voltage)</i>								
	Voltage Regulator	Test Replace		0.3 0.3					
0603	<i>Starting Motor</i>	Test Replace Repair		0.3 0.6					
0605	<i>Ignition Components</i>				1.5				
	Coil, Ignition	Test Replace		0.2 0.3					
	Spark Plug	Adjust Replace		0.3 0.5					
	Distributor, Ignition	Inspect Adjust Replace Repair		0.2 0.3 0.5 0.8					
0607	<i>Instrument or Engine Control Panel</i>								
	Panel, Instrument	Replace		1.0					
0608	<i>Miscellaneous Items</i>								
	Fuseholder, Block	Replace		0.2					
0609	<i>Lights</i>	Replace Repair		0.4 0.5					
0610	<i>Sending Units and Warning Switches</i>	Replace		0.4					
0611	<i>Horn</i>	Test Replace	0.1	0.5					
	Horn Button Assembly	Replace			0.5				
0612	<i>Batteries, Storage</i>	Inspect Test Service Replace	0.1	0.1 0.3 0.3					
	Cables, Batteries	Inspect Replace	0.1	0.3					
0613	<i>Chassis Wiring Harness</i>	Replace		2.5					

**Section II. MAINTENANCE ALLOCATION CHART -Continued**

(1) GROUP NUMBER	(2) COMPONENT ASSEMBLY	(3) MAINTENANCE FUNCTION	(4) MAINTENANCE CATEGORY					(5) TOOLS AND EQUIPMENT	(6) REMARKS
			C	O	F	H	D		
<b>07</b>	<b>TRANSMISSION</b>								
0705	<i>Transmission Shifting Components</i>								
	Bracket Assembly, Shifting Control	Replace Repair			1.0 2.0				
0708	<i>Torque Converter</i>	Replace			0.5				
0710	<i>Transmission Assembly</i>	Test Service Replace Repair Overhaul		0.3	2.0 8.0	12.0 16.0			
0713	<i>Intermediate Clutch</i>	Replace Repair				4.0 6.0			
0714	<i>Servo Unit</i>								
	Valve Assembly, Transmission	Replace Repair			1.0 2.0				
0721	<i>Coolers, Pumps, Motors</i>								
	Filter Element, Fluid Transmission Pump, Rotary	Replace Replace Repair		0.2		1.0 1.5			
<b>09</b>	<b>PROPELLER, PROPELLER SHAFTS, UNIVERSAL JOINTS, COUPLER, AND CLAMP ASSEMBLY</b>								
0900	<i>Propeller Shafts</i>								
	Universal Joint Assembly	Service Replace Repair		0.2 1.0 0.5					
<b>10</b>	<b>FRONT AXLE</b>								
1000	<i>Front Axle Assembly</i>								
	Shaft, Shouldered	Replace			2.0				
1002	<i>Differential</i>	Service Replace Repair		0.3	4.0	4.0			

**Section II. MAINTENANCE ALLOCATION CHART -Continued**

(1) GROUP NUMBER	(2) COMPONENT ASSEMBLY	(3) MAINTENANCE FUNCTION	(4) MAINTENANCE CATEGORY					(5) TOOLS AND EQUIPMENT	(6) REMARKS
			C	O	F	H	D		
<b>11</b>	<b>REAR AXLE</b>								
1100	Rear Axle Assembly	Service Replace		0.2	3.0				
1104	Steering, Sideshift, and Wheel Leaning Mechanism								
	Spindle, Wheel	Service Replace		0.2	2.0				
<b>12</b>	<b>BRAKES</b>								
1201	Hand Brakes Lever, Manual Control	Adjust Replace	0.1	0.7					
	Brake Shoe	Test Replace	0.1	1.0					
1202	Service Brakes								
	Brake Shoe	Replace		1.0					
1204	Hydraulic Brake System								
	Cylinder Assembly, Master	Service Replace		0.2 1.0					
	Cylinder Assembly, Wheel	Replace		1.0					
	Lines and Fittings	Replace Repair		1.0 1.0					
1206	Mechanical Brake System								
	Pedal Assembly, Inching Control	Adjust Replace		0.2 0.9					
<b>13</b>	<b>WHEELS</b>								
1311	Wheel Assembly	Replace		1.2					
1313	Tires	Inspect Replace	0.1			1.7			
<b>14</b>	<b>STEERING</b>								
1401	Mechanical Steering Gear Assembly								
	Steering Unit	Replace Repair			4.0	2.0			

**Section II. MAINTENANCE ALLOCATION CHART -Continued**

(1) GROUP NUMBER	(2) COMPONENT ASSEMBLY	(3) MAINTENANCE FUNCTION	(4) MAINTENANCE CATEGORY					(5) TOOLS AND EQUIPMENT	(6) REMARKS
			C	O	F	H	D		
1401	<i>Mechanical Steering Gear Assembly (Con't)</i>								
	Rod Assembly, Tie	Adjust Replace Repair		0.5 2.0 0.5					
1412	<i>Hydraulic or Air Cylinders</i>								
	Cylinder Assembly, Power	Replace Repair		1.0	2.0				
<b>15</b>	<b>FRAME, TOWING ATTACHMENTS, DRAWBARS, AND ARTICULATION SYSTEMS</b>								
1501	<i>Frame Assembly</i>								
	Counterweight	Replace		0.7					
	Pin, Tow, Frame	Replace		0.3					
<b>18</b>	<b>BODY, CAB, AND HOOD</b>								
1801	<i>Body, Cab, and Hood Assemblies</i>								
	Hood Assembly	Replace		1.0					
1805	<i>Floors and Related Components</i>	Replace		1.0					
1806	<i>Upholstery Seats</i>								
	Frame, Seat	Adjust Replace	0.1	0.5					
<b>22</b>	<b>BODY, CHASSIS AND ACCESSORY ITEMS</b>								
2210	<i>Data Plate</i>								
	Warning Decal	Replace		0.1					
<b>24</b>	<b>HYDRAULIC AND FLUID SYSTEMS</b>								
2401	<i>Pump and Motor</i>								
	Pump, Rotary	Test Replace Repair			0.5 1.0 2.0				

**Section II. MAINTENANCE ALLOCATION CHART - Continued**

(1) GROUP NUMBER	(2) COMPONENT ASSEMBLY	(3) MAINTENANCE FUNCTION	(4) MAINTENANCE CATEGORY					(5) TOOLS AND EQUIPMENT	(6) REMARKS
			C	O	F	H	D		
2402	<i>Manifold and/or Control Valves</i>								
	Valve, Linear, Direct	Replace Repair			1.0 2.0				
2403	<i>Hydraulic Controls and/or Manual Controls</i>								
	Link, Control Valve Lever	Replace			1.0				
2404	<i>Tilt Cylinders and Tilt Crank Cylinder Assembly, Tilt</i>								
		Adjust Replace Repair		0.2 0.5	1.5				
2405	<i>Mast Column</i>	Replace			2.0				
	Cylinders, Lift	Replace Repair			1.0 2.0				
	Carriage Assembly	Replace Repair			1.0 1.0				
2406	<i>Strainers, Filters, Lines and Fittings, Etc.</i>								
	Filter, Fluid, Pressure	Replace Repair		0.3 0.3					
	Lines and Fittings	Inspect Replace		0.2 0.5					
2408	<i>Liquid Tanks or Reservoirs</i>								
	Breather	Service Replace		0.2 0.1					
	Reservoir	Service Replace		0.2	0.7				
<b>76</b>	<b>FIRE FIGHTING EQUIPMENT COMPONENTS</b>								
7638	<i>Portable Fire Fighting Equipment</i>								
	Mounting Hardware	Replace		0.2					



### Section III. TOOL AND TEST EQUIPMENT REQUIREMENTS

Not Applicable.

### Section IV. REMARKS

Not Applicable.

*Page I-1, right column.*

Below *Brakes: Master cylinder*, add "Parking brake adjustment, paragraph 3-15, page 3-4".

Below *Brakes: Parking brake handle and linkage*, add "Pedal, brake and inching, paragraph 4-53.1, page 4-43".

By Order of the Secretary of the Army:

*Page I-4, left column.*

Below *Parking brake system.*, add "Adjustment, paragraph 3-15, page 3-4".

Below *Parking brake system: Description*, add "Pedal, brake and inching, paragraph 4-53.1, page 4-43".

Official:

WILLIAM J. MEEHAN II  
*Brigadier General, United States Army*  
*The Adjutant General*

CARL E. VUONO  
*General, United States Army*  
*Chief of Staff*

Distribution:

To be distributed in accordance with DA Form 12-25F (Block Nos. 2224, 2225), Operator and Unit maintenance requirements for Truck, Fork Lift, 6000 LB Capacity, Power Shift (Model MHE 212).

U.S. GOVERNMENT PRINTING OFFICE: 1990 743-024/00183

Change in force: C 1, C 2, and C 3

CHANGE }  
No. 3 }

HEADQUARTERS  
DEPARTMENT OF THE ARMY  
WASHINGTON, D.C., 03 April 1974

**Operator and Organizational Maintenance Manual**  
**TRUCK, LIFT, FORK; POWER SHIFT GE.D., 6,000 LB.**  
**CAPACITY, SRT, 180 IN. UFT**  
**(ALLIS CHALMERS MODEL F60-24PS-180,**  
**ARMY MODEL MHE 212) FSN 3930-4802 63**

TM 10-3930624-12, 2 March 1971, is changed as follows:

*Inside Front Cover.* Add the following warning to the list of safety precautions:

**WARNING**

**Operation of this equipment presents a noise hazard to personnel in the area. The noise level exceeds the allowable limits for unprotected personnel. Wear ear muffs or ear plugs which were fitted by a trained professional**

*Page 1-1.* Paragraph 14 is superseded as follows:

**1-4.Recommendation for Maintenance Publications Improvements**

You can help to improve this manual by calling attention to errors and by recommending improvements. Your letter or DA Form 2028 (Recommended Changes to Publications and Blank Forms) should be

mailed direct to: Commander, US Army Troop Support Command, ATTN. AMSTS-MPP, 4300 Goodfellow Blvd., St. Louis, MO 63120. A reply will be furnished directly to you.

*Page 2-3.* Immediately after the section IV title, add the following warning:

**WARNING**

**Operation of this equipment presents a noise hazard to personnel in the area. The noise level exceeds the allowable limits for unprotected personnel. Wear ear muffs or ear plugs which were fitted by a trained professional.**

*Page A-1.* In paragraph A-5, add the following reference: "TB MED 251, Noise and Conservation of Hearing."

By Order of the Secretary of the Army:

CREIGHTON W. ABRAMS  
*General, United States Army*  
*Chief of Staff*

Official:

VERNE L. BOWERS  
*Major General, United States Army*  
*The Adjutant General*

Distribution:

To be distributed in accordance with DA Form 12-25A, (qty rqr block No. 893) Operator Maintenance Requirements for Warehouse Equipment.

CHANGE }  
No. 2 }

HEADQUARTERS  
DEPARTMENT OF THE ARMY  
WASHINGTON, D.C., 17 May 1972

**Operator and Organizational Maintenance Manual**

**TRUCK, LIFT, FORK; POWER SHIFT, G.E.D.  
6000 LB CAPACITY, SRT, 180 IN. LIFT  
(ALLIS CHALMERS MODEL F60-24PS-180)  
(ARMY MODEL MHE-212)  
FSN 3930-489-0263**

---

TM 10930-62412, 2 March 1971, is changed as follows:

*Page 2-1.* Paragraph 2-1.1 is added as follows:

**2-1. Maintenance and Operating Supplies**

A list of maintenance and operating supplies required for

initial operation of the fork lift truck are contained in  
table 2-0.

Table 2-0. Maintenance and Operating Supplies

(1) COMPONENT APPLICATION	(2) MFR PART NO OR NAT'L STOCK NO.	(3) DESCRIPTION	(4) QTY REQ F/INITIAL OPN	(5) QTY REQ F/8 HRS OPN	(6) NOTES
Air Cleaner	9150-265-9435(2) 9150-265-9428(2) 9150-242-7603(2)	OIL, LUBRICATING: 5-gal drum as follows: OE 30 OE 10 OES	½ pt 1/2 pt 1/2 pt	(3) (3) (3)	(1) Includes quantity of oil fill engine oil system as follows: 6 qt-Engine crankcase 1 qt-Oil filter
Crankcase		OIL, LUBRICATING (4)  OE 30 OE 10  OES	7 qt (1) 7 qt (1)  7 qt (1)	(3) (3)  (3)	(2) See C9100-IL for additional data requisitioning procedures. (3) See current LO for grade application and replenishment intervals. (4) Use oil as prescribed for air cleaner.
Grease Points	9150-190-0905(2)	GREASE, AUTOMOTIVE AND ARTILLERY: 5-lb can as follows: GAA	5 lb	(3)	(5) Tank capacity.
Hydraulic Reservoir	9150-231-9071(2)	BRAKE FLUID, AUTOMOTIVE: 1 gal can as follows: HBA	5/16 qt	(3)	(6) Use oil as prescribed for reservoir.
Oil Can Points	9150-265-9429(2) 9150-242-7604(2)	OIL, LUBRICATING, ENGINE: 55-gal drum as follows: OE 10 OES	38 qt 38 qt	(3) (3)	
Radiator	6850-644-1409 6850-174-1806	OIL, LUBRICATING (4) OE 30 OE 10	16 qts		
Tank, Fuel	9130-160-1818(2) 9130-160-1830(2)	WATER, ANTIFREEZE: 55-gal drum as follows: ANTIFREEZE: Ethylene glycol ANTIFREEZE: Compound arctic	9 qts 16 qts		
Transmission, Torque Converter	9130-160-1818(2) 9130-160-1830(2)	FUEL, GASOLINE: Automotive; Bulk as follows: 91A 91C	8 3/4 gal 8 3/4 gal	(5) (5)	
Differential	9150-577-5844 9150-257-5440	OIL, LUBRICATING (6)  OE 10 OES OIL, GEAR: GO GOS (Sub 0)	11 qts 11 qts 5 gal can 5 pts 5 pts	(3) (3) (3) (3) (3)	

**APPENDIX B**

**BASIC ISSUE ITEMS LIST AND ITEMS TROOP INSTALLED OR AUTHORIZED**

**Section I. INTRODUCTION**

**B-1. Scope**

This appendix lists items required by the operator for operation of the fork lift truck.

**B-2. General**

This list is divided into the following sections:

a. *Basic Issue Items List-Section II.* Not applicable.

b. *Items Troop Installed or Authorized List Section III.* A list of items in alphabetical sequence, which at the discretion of the unit commander may accompany the fork lift truck. These items are NOT subject to turn-in with the fork lift truck when evacuated.

**B-3. Explanation of Columns**

The following provides an explanation of columns in the tabular list of Basic Issue Items List, Section II, and Items Troop Installed or Authorized, Section III.

a. Source, Maintenance, and Recoverability Code(s) (SMR):

(1) Source Code, indicates the source for the listed item. Source codes are:

<i>Code</i>	<i>Explanation</i>
P	Repair parts, special tools and test equipment supplied from GSA/DSA or Army supply system and authorized for use at indicated maintenance levels.
P2	Repair parts, special tools and test equipment which are procured and stocked for insurance purposes because the combat or military essentiality of the end item dictates that a minimum quantity be available in the supply system.

(2) Maintenance Code, indicates the lowest level of maintenance authorized to install the listed item. The maintenance level code is:

<i>Code</i>	<i>Explanation</i>
C	Crew/Operator

(3) Recoverability Code, indicates whether unserviceable items should be returned for reconveyor salvage. Items not coded are non-recoverable. Recoverability codes are:

<i>Code</i>	<i>Explanation</i>
R	Applied to repair parts (assemblies and components), special tools and test equipment which are considered economically repairable at direct and general support maintenance levels.
S	Repair parts, special tools, test equipment and assemblies which are economically repairable at DSU and GSU activities and which normally are furnished by supply on an exchange basis.

b. *Federal Stock Number.* This column indicates the Federal stock number assigned to the item and will be used for requisitioning purposes.

c. *Description.* This column indicates the Federal item name and any additional description of the item required.

d. *Unit of Measure (U/M).* A 2 character alphabetic abbreviation indicating the amount or quantity of the item upon which the allowances are based, e.g., ft, ea, pr, etc.

e. *Quantity Furnished With Equipment (BILL only).* This column indicates the quantity of an item furnished with the equipment.

f. *Quantity Authorized (Items Troop Installed or Authorized Only).* This column indicates the quantity of the item authorized to be used with the equipment.

g. *Illustration (BILL only).* This column is divided as follows:

(1) *Figure Number.* Indicates the figure number of the illustration in which the item is shown.

(2) *Item Number.* Indicates the callout number used to reference the item in the illustration.

**Section III. ITEMS TROOP INSTALLED OR AUTHORIZED LIST**

(1) SMR Code	(2) Federal stock No.	(3) Description  Ref No, & Mfr code	(4) Unit of meas  Usable on code	(5) Qty Auth
	7510-889-3494	BINDER, LOOSE LEAF	EA	1
	7520-559-9618	CASE, MAINTENANCE AND OPERATING MANUALS	EA	1
	4210-889-2221	EXTINGUISHER, FIRE	EA	1

By Order of the Secretary of the Army:

Official:

VERNE L. BOWERS,  
*Major General, United States Army,  
The Adjutant General.*

W. C. WESTMORELAND,  
*General, United States Army,  
Chief of Staff.*

Distribution:

To be distributed in accordance with DA Form 12-25A, (qty rqr block No. 893) Operator Maintenance Requirements for Warehouse Equipment.

CHANCE }  
No. 1 }

HEADQUARTERS  
DEPARTMENT OF THE ARMY  
WASHINGTON, D.C., 1 September 1971

**Operator and Organizational Maintenance Manual**  
**TRUCK, LIFT, FORK, POWER SHIFT G.E.D., 6,000 LB.**  
**CAPACITY, SRT. 180 IN. LIFT**  
**(ALLIS CHALMERS MODEL F60-24PS-180)**  
**(ARMY MODEL MHE 212) FSN 3930-489-0263**

TM 10-3930-624-12, 2 March 1971, is changed as follows:

*Page iv.* After "4-61 Hydraulic Oil Filter" add the following: "4-61.1 Mast and carriage chain, removal" and adjustment."

*Page 3-2.* Paragraph 3-2f(1) is superseded as follows:

(1) Remove the floor plate to gain access to the dipstick located on the right side of the transmission case. Refer to figure 3-3.

Paragraph 3-2f(3). In line 4 change "transmission fluid" to read "oil".

Paragraph 3-2f(4) is superseded as follows:

(4) Install the floor plate.

Paragraph 3-2h. Add "Coolant should be as specified in table 2-1"

Paragraph 3-2i(1). In line 1 change "regularly" to read "weekly".

*Page 3-3, Table 3-1.* In "Procedure column", for sequence number 2, add "and replenish as necessary to bring to full mark on dipstick".

Table 3-1. In "Procedure column," for sequence number 3, add "Coolant should be as specified in table 2-1".

In the "Before Operation column" delete sequence number "10" and add "10" to line 10 in the "During Operation column".

*Page 3-3, table 3-2.* In the "Corrective Action" column for item 1, add "and add fuel as required".

In the "Corrective Action" column for Item 2, add "Reference Section III of Basic Issue Items List for correct grade of fuel.

In the "Corrective Action" column for item 4, and add

"with coolant as specified in table 2-1".

In the "Corrective Action" column for item 8 add "(para 3-2e).

In "Corrective Action" column for item 7a, add "(para 3-2d)".

In the "Corrective Action" column for item 7b, add "Report defective oil lines to organizational maintenance".

In the "Corrective Action" column for item 9, add para 3-2f".

In the "Probable Cause" and "Corrective Action" columns for item 11, delete paragraph "b".

*Page 3-4, paragraph 3-11.* In line 1 change "At periodic intervals" to read "At 100 hour intervals".

*Page 4-2, table 4-1.* In the "Reference" column for item 1, add "para 4-31".

In the "Reference" column for item 7, change "p 4-63" to read "para 4-65".

In the "Procedure" column for item 7, delete "place if clogged or dirty" and substitute "Service". In the "Reference" column for item 8, change "4-61" to read "para 4-60 thru para 4-65".

In "Reference" column for item 10, change "4-51" to read "para 4-51 thru para 4-52".

In the "Reference" column for item 13, add "4-26".

Item 17 is added as follows:

Add to column 2 "Mast"

Add to column 3 "Inspect and adjust if necessary".

Add to column 4 "para 4-65"



Page 4-9, paragraph 4-15c(l). In line 1 change "Remove rocker arm cover" to read "Remove crankcase ventilation line (para 4-16), rocker arm cover".

Paragraph 4-15c(3). In line 1 change "check the clearance" to read "With the engine cold, check the clearance".

Page 4-12, paragraph 4-17b(1). In line 1 delete "Filter" and substitute "Cover and case".

Paragraph 4-17c(3). Add "reinstall the inlet and outlet lines from the filter case (7). Replace the screw (8), lockwasher (9), nut (10), and strap (11) securing the case (7)".

Paragraph 4-18a(3). Add note as follows:

**NOTE**

**Remove the 2 clamps which secure the PCV line.**

Paragraph 4-18c(3). Add "reconnect the fitting which secures the positive crank-case ventilation valve to the bottom of the manifold. Reinstall the clamps which secure the PCV line".

Page 4-14, paragraph 4-18c(5). Delete the second sentence.

Page 4-34, paragraph 4-39c(2). Change second sentence to read "Remove the front grille and remove battery by sliding horizontally from the battery compartment".

Page 4-40, paragraph 4-50. Add subparagraph "e" as follows:

*e. Hand Brake Lever Assembly Removal.*

(1) Add slack to the hand brake cable. Refer to paragraph c above.

(2) Remove cotter pin and pin securing the brake cable to the hand brake lever.

(3) Remove the nuts (2), washers (2), and screws (2), securing clamp and plate to hand e assembly. Remove clamp, plate and spacer.

(4) Remove hand brake cable from hand brake assembly.

(5) Remove acorn nuts (2) from the carriage bolts (2) securing hand brake assembly to the side

**NOTE**

**To prevent the square neck carriage bolts from moving axially out of square holes in the left side panel when the spacers and hand brake assembly are being installed, wrap the shank of the carriage bolt as it protrudes from the side panel with one or two warps of tape.**

(6) Install hand brake assembly in reverse procedure of removal.

Page 4-48, paragraph 4-64. Add the following note after subparagraph c(2).

**NOTE**

**Do not overtighten cover nut.**

Page 4-49. Paragraph 4-65.1 is added as follows:

**4-65.1. Mast and Carriage Chain, Removal and Adjustment**

*a. Removal.*

(1) Lower mast and carriage to the lowest limit (fig. 4-67).

(2) Attach chain hoist to the carriage and raise slightly to relieve tension on the lift chains.

(3) Refer to figure 4-61.1 and remove cotter pins and chain links from bolts. Remove chains from chain anchors on carriage in a similar manner.

(4) Lift chains over chain bearings and remove from mast.

*b. Cleaning and Inspection.*

(1) Clean chains with a cleaning compound (SPEC. P-S-661) and dry thoroughly.

(2) Inspect chain for bent, cracked or damaged links.

(3) Lubricate chains with oil (OE).

*c. Installation.*

(1) Install chains in reverse order of removal.

(2) Operate lift mechanism and check chains for binding or uneven operation. With cylinder fully retracted, carriage should be level and forks should not touch the floor. Refer to *d* below for chain adjustment.

*d. Chain Adjustment.*

*(1) Carriage chain adjustment.*

*(a)* Lower carriage to its lowest point of travel.

*(b)* The bottom of the carriage lower bar should be 3.0 to 3.5 inches from the floor.

*(c)* Adjust the chain adjusting bolts as necessary.

*(2) Mast chain adjustment.*

*(a)* Start engine and allow to idle.

*(b)* Extend mast to its maximum height. Measure the distance between the inner stop and crosshead support on the intermediate mast. The clearance should be between 1/64 and 1/32 inch.

*(c)* Adjust chain bolts as necessary to achieve above dimensions.

**NOTE**

**Insure that chains are adjusted to equal tension.**

Page 4-49. Figure 4-61.1 is added as follows:

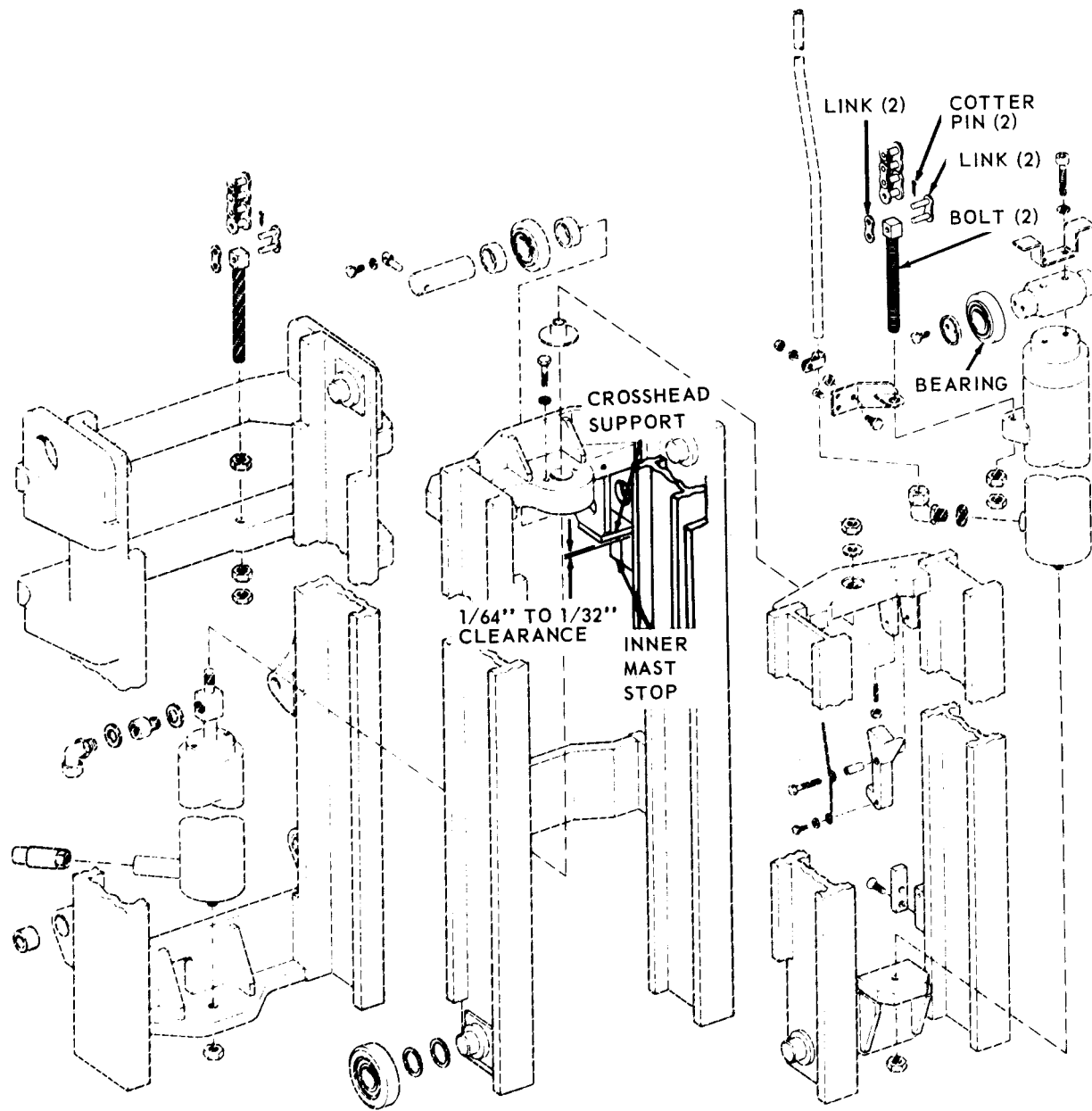

ME 3930-624-12/4-61.1

Figure 4-61.1. Mast and carriage chain, removal and adjustment.

Page C-3, Maintenance Allocation Chart. Add the following to group 13.

Chain            Inspect 0            Adjust 0            Replace 0

By Order of the Secretary of the Army:

Official:

VERNE L. BOWERS,  
*Major General, United States Army,  
The Adjutant General*

W. C. WESTMORELAND,  
*General, United State Army,  
Chief of Staff.*

Distribution:

To be distributed in accordance with DA Form 12-25A (qty rqr Block #191). Operator requirements for Warehouse Equipment: Gasoline.

**OPERATOR AND ORGANIZATIONAL MAINTENANCE MANUAL**

**TRUCK, LIFT, FORK, POWER SHIFT, G.E.D., 6,000 LB**

**CAPACITY, SRT, 180 IN. LIFT (ALLIS-CHALMERS**

**MODEL F60-24PS-180) (ARMY MODEL MHE 212)**

**FSN 3930-489-0263**

		Paragraph	Page
CHAPTER	1 INTRODUCTION		1-1
Section	I. General.....	1-1	1-1
	II. Description and data .....	1-5	1-1
CHAPTER	2 OPERATING INSTRUCTIONS		2-1
Section	I. Service upon receipt of material.....	2-1	2-1
	II. Movement to a new worksite .....	2-2	2-1
	III. Controls and instruments .....	2-4	2-1
	IV. Operations under usual conditions .....	2-6	2-3
	V. Operations under unusual conditions.....	2-10	2-4
CHAPTER	3 OPERATOR'S MAINTENANCE INSTRUCTIONS		3-1
Section	I. Lubrication instructions .....	3-1	3-1
	II. Preventive maintenance checks and services.....	3-3	3-2
	III. Troubleshooting .....	3-5	3-3
	IV. Maintenance of the engine .....	3-6	3-4
	V. Maintenance of the air cleaner .....	3-8	3-4
	VI. Maintenance of the fuel tank .....	3-10	3-4
	VII. Maintenance of the radiator.....	3-12	3-4
CHAPTER	4 ORGANIZATIONAL MAINTENANCE INSTRUCTIONS		4-1
Section	I. Service upon receipt of material.....	4-1	4-1
	II. Repair parts, special tools, and equipment.....	4-3	4-1
	III. Lubrication instructions .....	4-6	4-2
	IV. Preventive maintenance checks and services.....	4-8	4-2
	V. Troubleshooting .....	4-10	4-2
	VI. Radio interference suppression .....	4-11	4-8
	VII. Maintenance of the engine .....	4-15	4-9
	VIII. Maintenance of the fuel system.....	4-19	4-14
	IX. Maintenance of the air induction and exhaust system.....	4-25	4-20
	X. Maintenance of the cooling system .....	4-27	4-22
	XI. Maintenance of the electrical system .....	4-32	4-25
	XII. Maintenance of the transmission.....	4-44	4-37
	XIII. Maintenance of the shafts and axles .....	4-46	4-40
	XIV. Maintenance of the brakes.....	4-49	4-40
	XV. Maintenance of the wheels.....	4-54	4-44
	XVI. Maintenance of the steering system .....	4-57	4-45
	XVII. Maintenance of the hydraulic lift components.....	4-60	4-47
	XVIII. Maintenance of the body.....	4-66	4-49
CHAPTER	5 MATERIAL USED IN CONJUNCTION WITH THE TRUCK		5-1

	<b>Paragraph</b>	<b>Page</b>
APPENDIX A. References .....		A-1
B. Basic Issue Items List .....		B-1
C. Maintenance Allocation Chart .....		C-1
INDEX .....		I-1

## LIST OF ILLUSTRATIONS

<i>Number</i>	<i>Title</i>	<i>Page</i>
1-1	Truck, forklift, left front, three quarter view .....	1-1
1-2	Truck, forklift, right rear, three quarter view .....	1-1
1-3	Wiring diagram .....	1-5
1-4	Hydraulic diagram .....	1-6
1-5	Transmission and torque converter hydraulic system diagram .....	1-7
2-1	Controls and instruments .....	2-2
2-2	Shift, lift, and tilt pattern .....	2-4
3-1	Checking crankcase oil level .....	3-1
3-2	Air cleaner .....	3-1
3-3	Transmission dipstick .....	3-2
4-1	Battery connections .....	4-1
4-2	Valve clearance adjustment .....	4-10
4-3	Crankcase ventilation .....	4-11
4-4	Oil filter .....	4-12
4-5	Manifold .....	4-13
4-6	Manifold mounting .....	4-14
4-7	Carburetor adjustment .....	4-14
4-8	Fuel pump .....	4-15
4-9	Fuel tank .....	4-16
4-10	Governor adjustment .....	4-17
4-11	Fuel filter .....	4-18
4-12	Accelerator controls .....	4-19
4-13	Air cleaner and connections .....	4-20
4-14	Exhaust system .....	4-21
4-15	Reverse flushing the radiator .....	4-22
4-16	Reverse flushing the engine block .....	4-23
4-17	Thermostat location .....	4-23
4-18	Water pump and fan blade .....	4-24
4-19	Fan belt adjustment .....	4-24
4-20	Hydraulic pump removal .....	4-25
4-21	Checking alternator output .....	4-25
4-22	Voltage regulator .....	4-26
4-23	Checking voltage regulator setting .....	4-27
4-24	Starting motor .....	4-28
4-25	Distributor .....	4-29
4-26	Adjusting contact gap .....	4-29
4-27	Breaker point gap .....	4-30
4-28	Distributor timing adjustment .....	4-30
4-29	Flywheel timing mark .....	4-30
4-30	Timing light connections .....	4-31
4-31	Distributor assembly .....	4-32
4-32	Spark plug gap .....	4-33
4-33	Ignition coil .....	4-33
4-34	Battery location .....	4-34
4-35	Unlocking instrument panel from lock pins .....	4-35
4-36	Instrument panel anchor pins .....	4-35
4-37	Instrument panel gages, meters, and switches .....	4-35
4-38	Headlight assembly .....	4-36
4-39	Taillight assembly .....	4-36
4-40	Horn mounting and adjusting screw .....	4-37
4-41	Horn relay .....	4-37
4-42	Transmission drain plug .....	4-38
4-43	Transmission oil filter element .....	4-38
4-44	Transmission lines, fittings and filter .....	4-39
4-45	Universal joint and propellor shaft .....	4-40
4-46	Parking brake removal .....	4-41

<b>Number</b>	<b>Title</b>	<b>Page</b>
4-47	Parking brake assembly .....	4-41
4-48	Hand brake adjustment.....	4-41
4-49	Dust shield .....	4-42
4-50	Self-adjusting brakes .....	4-42
4-51	Master cylinder .....	4-43
4-52	Pedal lash adjustment .....	4-43
4-53	Wheel removal.....	4-44
4-54	Tie rod removal (pivot arm end) .....	4-45
4-55	Tie rod removal (steer knuckle end) .....	4-46
4-56	Tie rod assembly .....	4-46
4-57	Power steering cylinder removal.....	4-47
4-58	Checking mast tilt angle .....	4-47
4-59	Tilt cylinder yoke .....	4-48
4-60	Hydraulic oil reservoir.....	4-48
4-61	Hydraulic oil filter.....	4-49
4-62	Grille removal.....	4-50
4-63	Hood, side panels, seat support, and front grille.....	4-51
4-64	Counterweight removal.....	4-52
4-65	Floor and toe plates.....	4-53
4-66	Overhead guard removal.....	4-53
4-67	Fork removal.....	4-54
5-1	Fire extinguisher.....	5-1

# CHAPTER 1 INTRODUCTION

## Section I. GENERAL

### 1-1. Scope

a. The instructions in this manual are for the use of personnel to whom the F60-24PS-180 Forklift Truck is issued. They provide procedures for Operator and Organizational levels of maintenance for the equipment and its accessories.

b. Instructions for destruction of material to prevent enemy use will be in accordance with TM 750-244-3 (Procedures for Destruction of Equipment to Prevent Enemy use).

c. Preparation, care and removal of equipment in administrative storage will be in accordance with applicable requirements of TM 740-90-1 (Administrative Storage of Equipment).

### 1-2. Forms and Records

DA Forms and Records used for equipment maintenance will be those prescribed in TM 38-750.

### 1-3. Equipment Serviceability Criteria

Not applicable to this equipment.

### 1-4. Reporting of Errors

Reporting of errors, omissions, and recommendations for improving this publication by the individual users is encouraged. Reports should be submitted on DA Form 2028, (Recommended Changes to Publications), and forwarded directly to Commanding General U.S. Army Mobility Equipment Command, ATTN: AMSME-MPP, 4300 Goodfellow Blvd., St. Louis, Mo. 63120.

## Section II. DESCRIPTION AND DATA

### 1-5. Description

a. General. The Model F60-24PS-180 forklift truck (fig. 1-1 and 1-2) is built by the Allis-Chalmers Manufacturing Co. It is powered by gasoline engine, Model 6MB-230 and has a lifting capacity of 6000 pounds.

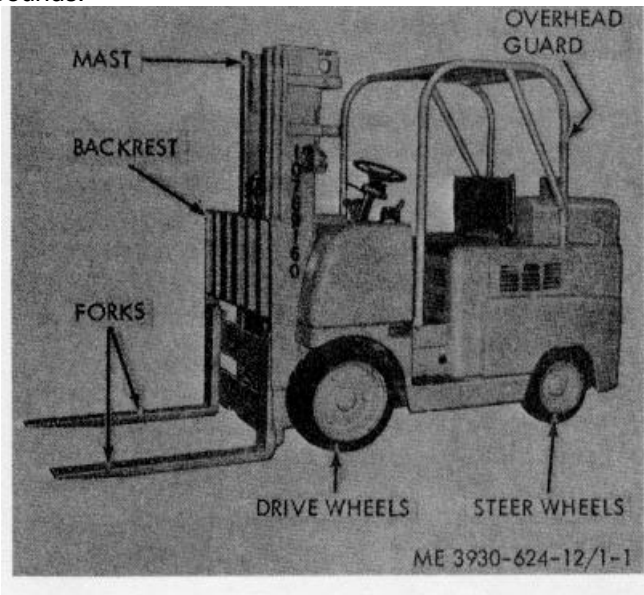

Figure 1-1. Truck, forklift, left front, three quarter view.

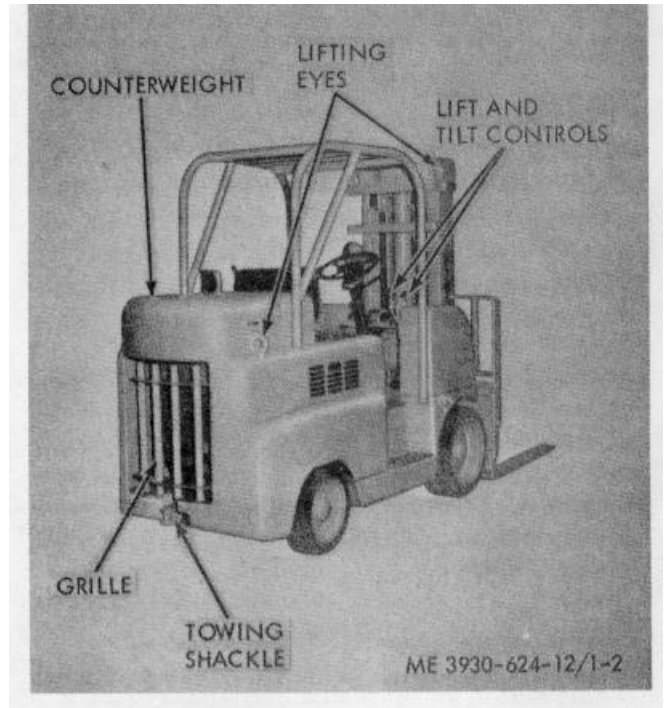

Figure 1-2. Truck, forklift, right rear, three quarter view.



*b. Engine.* The engine is of the four-stroke cycle design incorporating an over head valve arrangement. Engine cooling is accomplished by a belt-driven centrifugal pump forcing coolant through the head, block, and large tubular fin-type radiator. The engine is pressure lubricated to the rocker arms, main bearings, and connecting rods by a gear type oil pump driven by the camshaft. The oil is cleaned by a replaceable oil filter. Crankcase emission is eliminated via valve cover-to-intake manifold and block-to-air cleaner systems.

*c. Transmission.* The power-shift transmission consists of three major components: a constant-mesh transmission, a hydraulically actuated clutch pack, and a torque converter. A single lever shift control is mounted on the right of the steering column and controls the direction of travel through a control valve mounted on the transmission housing.

*d. Drive Unit.* The drive unit incorporates a double-reduction gear train. 1 parts of the unit are bearing-mounted. The first reduction is through a heavy duty spiral bevel ring gear and pinion drive gear. The final reduction is obtained through a pinion (axle shaft) and internal tooth gear (bull gear).

*e. Service Brakes.* The hydraulic self-adjusting brakes are located in each drive wheel. They have a large braking area and give smooth braking and positive control under all operating conditions.

*f. Parking Brake.* The parking brake is mounted on the differential case, and the brake drum is mounted on the differential-drive pinion flange. The parking brake handle is located within easy reach of the operator's left hand.

*g. Steering.* Steering of the lift truck is accomplished with full hydraulic power from a hydraulic cylinder. Rotation of the steering wheel operates a hydraulic valve, sending hydraulic pressure to the steering cylinder. Hydraulic oil pressure is supplied by the hydraulic pump mounted below the radiator. The pump also provides hydraulic oil pressure to operate the lift and tilt cylinders. Refer to figure 1-4 for schematic drawing of the hydraulic system.

*h. Mast.* The mast assembly consists of special rolled steel channel sections and is of all-welded construction. Two independent lift chains are utilized for safety, and each chain has sufficient strength to handle a full load safely. A seat at the bottom of the mast permits self-alignment of the lift cylinder within the mast channels, thus reducing off center stresses.

*i. Fork Carriage.* The fork carriage is a heavy-duty structure of welded steel built to provide the ultimate in strength and visibility with a minimum of overhang from the center of the drive wheels to the face of the forks.

The forks are mounted on the fork carriage supports at the top and bottom by fork anchors. The top carriage support is notched for positioning the forks, with a locking device in the top fork anchor to prevent shifting. The forks are identical to eliminate the necessity of a right and left fork.

*j. Hydraulic System.* Hydraulic pressure used to actuate the cylinders or accessory equipment is supplied by a positive-displacement gear pump coupled directly to the engine crankshaft. A control valve with handles conveniently located to the right of the operator actuates the lift and tilt cylinders or attachments. The hydraulic oil reservoir has more than ample capacity for normal displacement needs.

*k. Instrument Panel.* The instrument panel, located directly in front of the driver, has a complete set of electrical gages. These include an oil pressure gage, fuel gage, engine coolant temperature gage, ammeter, and a direct reading engine hour meter. The ignition starting switch and choke control are also located on the panel.

*l. Electrical System.* The truck utilizes a 12 volt electrical system which consists of a 12 volt battery, heavy duty alternator, voltage regulator, starting motor, solenoid switch, and horn. The electrical gages are protected by fuses in the circuit. Gage fuses and horn fuse are located at the right underside of the instrument panel.

**1-6. Identification and Tabulated Data**

*a. Identification.* The fork lift truck has five major identification plates.

- (1) The truck model and serial number plate is located near the center of the instrument panel.
- (2) The engine model and serial number plate is located on the left side of the cylinder block.
- (3) The battery caution plate is located on the right hand seat angle.
- (4) The shipping plate is located in the driver's compartment on the inside of the right hand cowl.
- (5) The air cleaner service plate is located on the left hand seat angle, near the air cleaner.

*b. Tabulated Data.*

(1) *Capacities.*

Cooling System .....	16 quarts
Engine crankcase (with filter) ....	7 quarts
Drive Axle .....	5 pints
Fuel tank.....	8.3 gallons
Air cleaner.....	1/2 pint
Hydraulic system.....	9 gallons
Transmission (with filter) .....	11 quarts
Brake system .....	3/4 pint

(2) *Truck, fork lift.*  
 Manufacturer..... Allis-Chalmers  
 Model..... F60-24PS-180  
 U.S. Army Registration Nrs .. 10769009 thru 10769338

(3) *Engine*  
 Manufacturer..... Allis-Chalmers  
 Manufacturer part number.... 415261  
 Model..... 6MB-230  
 Type..... Gasoline  
 Displacement ..... 230 cubic inches  
 Power..... 55 horsepower at 2200rpm  
 Torque ..... 153 ft lbs at 1200 rpm  
 Number of cylinders ..... 6 - in line  
 Bore ..... 3-7 / 16"  
 Stroke ..... 4 1/8"  
 Firing order ..... 1-5-3-6-2-4  
 Compression ratio ..... 8.0 to 1  
 Cycles ..... 4

(4) *Air cleaner*  
 Manufacturer..... United Air Cleaner  
 Model..... 14CX87A  
 Type..... Oil bath

(5) *Carburetor*  
 Manufacturer..... Zenith Carburetor Division  
 Manufacturer part number.... 0-13151  
 Model..... 267-J8  
 Type..... Up-draft, single barrel

(6) *Alternator, electrical*  
 Manufacturer..... Delco-Remy  
 Manufacturer part number.... 1100877  
 Model..... 10-DN  
 Type..... 12 volt negative ground  
 Voltage output..... 12 volts  
 Current output ..... 22 amps  
 Rotation ..... Clockwise

(7) *Starter, electrical*  
 Manufacturer..... Delco-Remy  
 Manufacturer part number.... 1107325  
 Type..... 12 volt, negative ground  
 Amperage draw ..... 5 amps/ 103 volts 6900 rpm  
 Rotation ..... Clockwise

(8) *Transmission*  
 Manufacturer ..... Warner Gear  
 Manufacturer part number.... 10-01-000-001  
 Model..... T12  
 Type..... Single range  
 Gear ratio:  
 Forward ..... 1.19: 1  
 Reverse ..... 1.19: 1  
 Maximum input torque ..... 350 ft lbs  
 Maximum input speed ..... 2200 rpm  
 Pressure:  
 Main ..... 100-140 psi  
 Converter..... 55-80 psi  
 Lube ..... 12-30 psi

(9) *Drive axle*

Manufacturer..... Allis Chalmers  
 (10) *Radiator*  
 Manufacturer..... Young Radiator  
 Manufacturer part number.... D238471  
 Pressure rating of cap ..... 4 psi  
 (11) *Cylinder, master, brake*  
 Manufacturer..... Wagner Electric  
 Manufacturer part number.... FE24728  
 Type..... Combination reservoir and cylinder

(12) *Wheel cylinder*  
 Manufacturer..... Wagner Electric  
 Manufacturer part number.... FD20945A  
 Type..... Standard straight bore, double end

(13) *Power steering cylinder*  
 Manufacturer..... Bruning Co  
 Manufacturer part number.... 6802-061  
 Type..... Single plunger  
 Stroke ..... 8 in

(14) *Steering gear*  
 Manufacturer..... Char-Lynn  
 Manufacturer part number.... UC3-01SCK  
 Type..... Hydraulic

(15) *Battery*  
 Manufacturer..... Autolite  
 Manufacturer part number.... 26-1597-D  
 Type..... 12 volt dry charge  
 Model..... 2SM-C  
 Rating (amp/hour) ..... 60 amp hour 20 hour  
 Filling capacity (electrolyte).. 425 quarts  
 Unpacked weight ..... 42 pounds

(16) *Tires (drive)*  
 Manufacturer ..... Goodyear  
 Model..... Goodyear-Xtra Cush  
 Type..... Non-directional tread, lug type, pressed on cushion tire, universal compound  
 Size ..... 22 x 9 x 16

(17) *Tires (steer)*  
 Manufacturer ..... Goodyear  
 Model..... Goodyear-Xtra Cush  
 Size ..... 18 x 6 x 121/8  
 Type..... Non-directional tread

(18) *Hydraulic pump*  
 Manufacturer ..... Tyrone Hydraulics  
 Manufacturer part number.... GPA2-1 15A  
 Model..... DD  
 Type..... Positive gear type  
 Primary flow ..... 2-3 gpm  
 Secondary flow ..... 18-19 gpm  
 Speed (max) ..... 2200 rpm  
 Pressure (max) ..... 2000 psi  
 Primary flow relief valve..... 1600 - 100 psi setting  
 Rotation ..... Counterclockwise  
 Drive ratio, engine to pump.. 1:1



(25) Wiring diagram. Refer to figure 1-3 for wiring diagram.

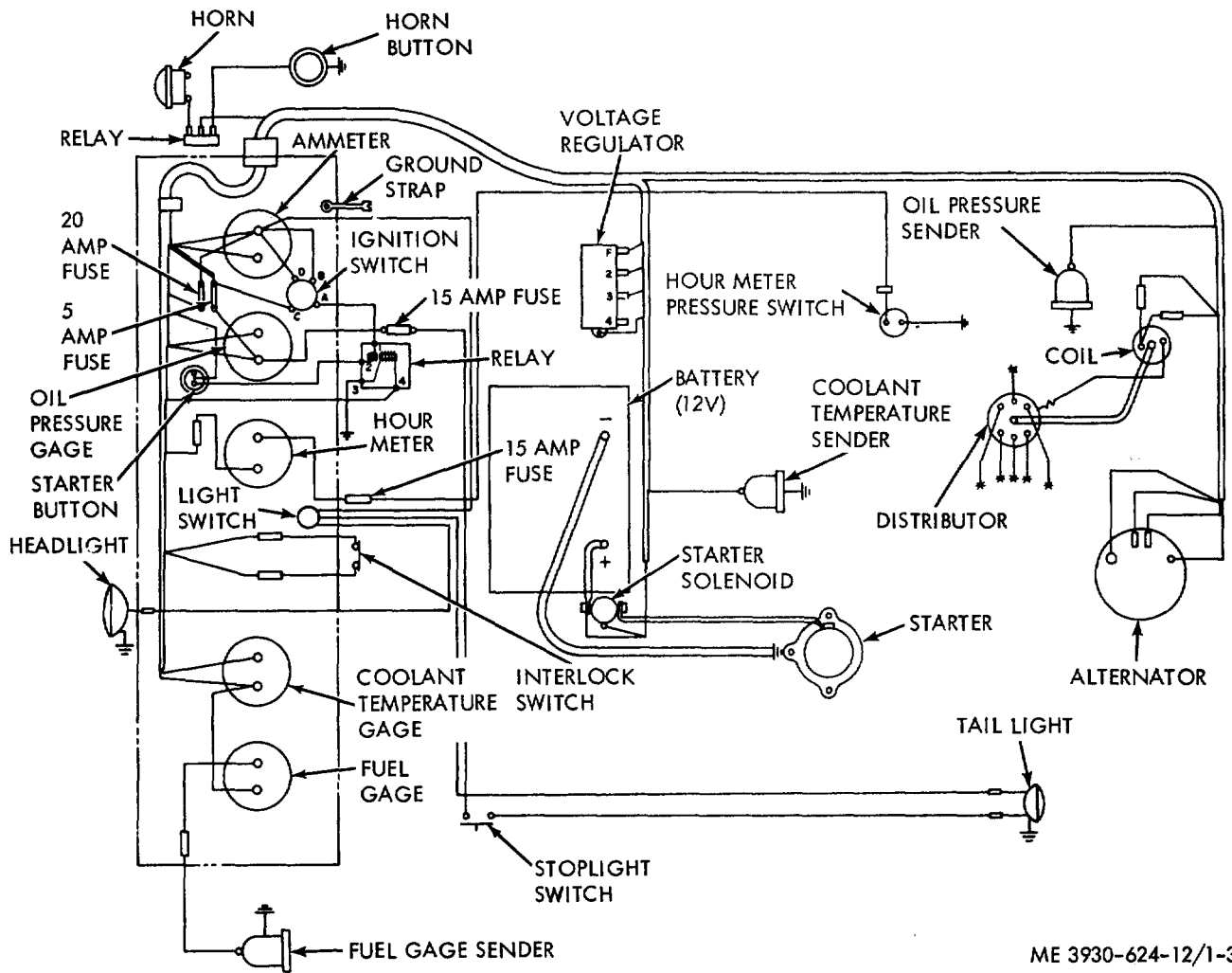
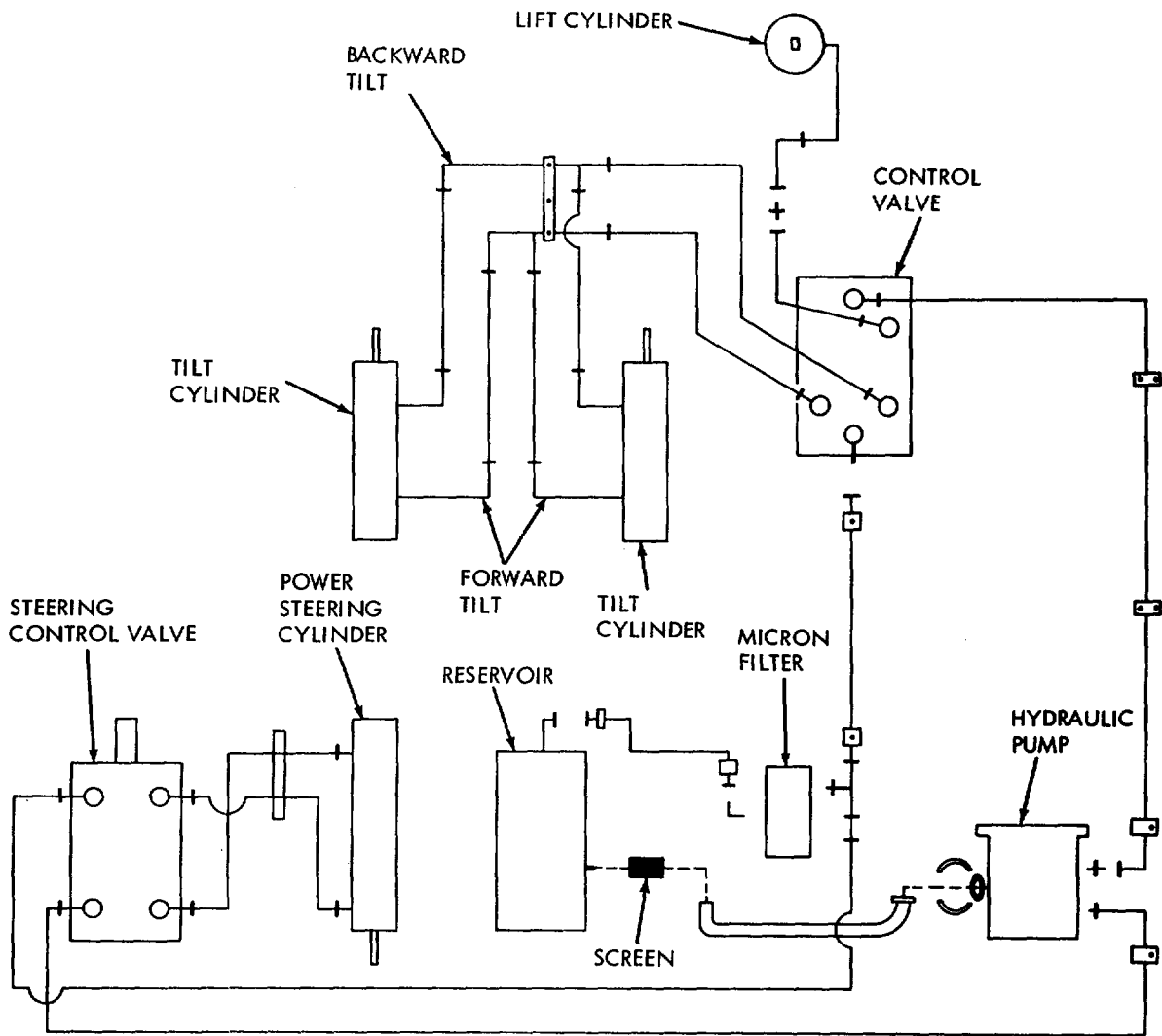

Figure 1-3. Wiring diagram.

(26) Hydraulic diagram. Refer to figure 1-4 for hydraulic diagram.



ME 3930-624-12/1-4

Figure 1-4. Hydraulic diagram.

(27) Transmission and torque converter hydraulic system diagram. Refer to figure 1-5.

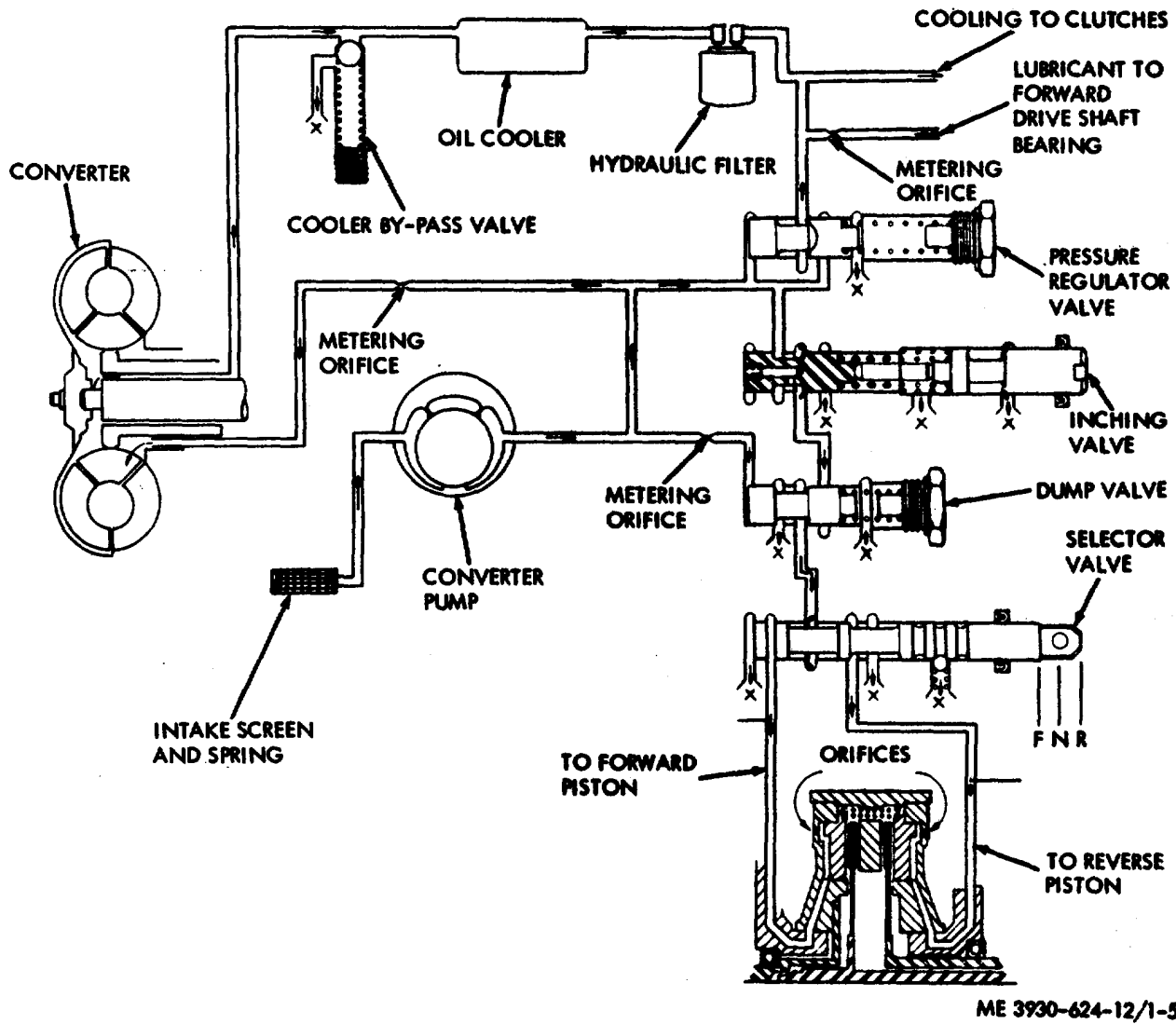

Figure 1-5. Transmission and torque converter hydraulic system diagram.

**CHAPTER 2  
OPERATING INSTRUCTIONS**

**Section I. SERVICE UPON RECEIPT OF MATERIAL**

**2-1. Inspecting and Servicing the Equipment**  
Perform the daily maintenance checks and services

as described in table 3-1.

**Section II. MOVEMENT TO A NEW WORKSITE**

**2-2. Dismantling for Movement**

**a.** For short-distance movement over hard surfaces, no dismantling is necessary to move the truck. The truck is self-propelled and can be driven directly to the worksite.

**b.** If the new worksite is too far to conveniently drive the truck to the new location, or if the worksites are separated by other than smooth,

hard-surfaced roads, the truck can be moved on a flatbed truck.

**2-3. Reinstallation after Movement**

If it was necessary to remove the overhead guard and the forks, reinstall them on the truck. Refer to paragraphs 4-73 and 4-74.

*Table 2-1. Freezing Points, Composition, and Specific Gravities of Military Antifreeze Materials*

Lowest expected ambient temp° F	Pints of inhibited glycol per gal. of coolant <sup>1</sup>	Compound, antifreeze arctic <sup>2</sup>	Ethylene glycol coolant solution specific gravity at 68° F <sup>3</sup>
+20	1 1/2	Issued full strength and ready mixed for 0° to -65° temperatures for both initial installation and replenishment of losses.	1.022
+ 10	2		1.036
0	2 3/4		1.047
-10	3 1/4		1.062
-20	3 1/2		1.062
-30	4		1.067
-40	4 1/4		1.073
-50	Arctic Antifreeze preferred.		DO NOT DILUTE WITH WATER OR ANY' OTHER SUBSTANCE.
-60			
-75			

<sup>1</sup>Maximum protection is obtained at 60percent by volume (4.B pints of ethylene glycol per gallon of solution).

<sup>2</sup>Military Specification MIL-C-11755 Arctic type, nonvolatile antifreeze compound is intended for use in the cooling systems of liquid-cooled internal combustion engines. It is used for protection against freezing primarily in Arctic regions where the ambient temperature remains for extended periods close to -40°F or drops below, to as low as -90° F.

<sup>3</sup>Use an accurate hydrometer. To test hydrometer use 1 part ethylene glycol antifreeze to 2 parts water. This should produce a hydrometer reading of 0°F.

Note. Fasten tag near radiator filler cap indicating the type antifreeze.

**Section III. CONTROLS AND INSTRUMENTS**

**2-4. General**

This section describes the various controls and instruments and provides the operator / crew with sufficient information to insure proper operation of the F60-24PS-180 fork lift truck.

**2-5. Controls and Instruments**

Refer to figure 2-1 for the location of the various instruments and controls.

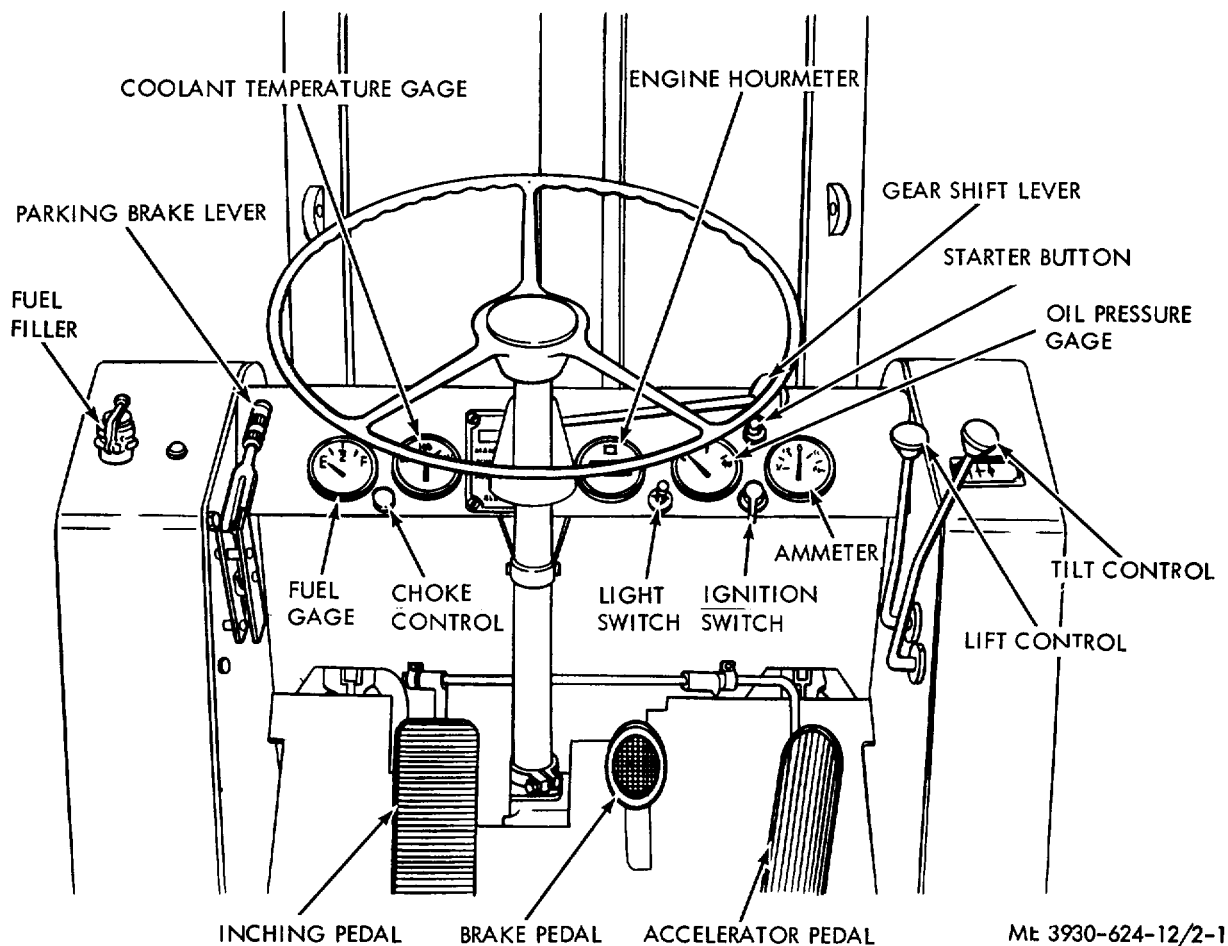

Figure 2-1. Controls and Instruments.

a. Controls.

(1) *Steering wheel.* The steering wheel is operated in the conventional manner. The steer, or trail, wheels are located at the rear of the truck. This will cause the rear of the truck to swing out when a turn is made.

(2) *Forward-reverse lever-- power shift.* The power shift lever is on the steering column beneath the steering wheel for right hand operation. There are three positions - forward, neutral, and reverse. The lever actuates a hydraulic valve mounted on top of the transmission; this directs the flow of oil to actuate forward and reverse pistons in the clutch drum assembly.

**Note.** The engine (cannot be started unless the power shift lever is in the neutral position.

(3) *Lift and tilt control.* The lift and tilt controls are located in the operator's compartment to the right of the instrument panel.

(4) *Parking brake lever.* The parking brake lever is a camaction, overcenter type, located near the instrument panel at the left side of the operator's comp-

partment. It actuates an enclosed, dual shoe mechanical unit which is mounted on the drive shaft. A small knob on the handle permits adjustment to compensate for brake lining wear.

(5) *Inching control-power shift.* The inching pedal is located at the left side of the steering column and is operated with the left foot. Changing the pedal stroke varies the oil pressure in the clutch pack so that an "inching" operation can be performed without losing full engine power necessary for fast lifts. The lower the pedal is depressed, the slower the truck will travel.

(6) *Brake pedal.* The brake pedal operates the brake master cylinder, which in turn actuates the wheel cylinder and brake shoes. The brake pedal is on the right side of the steering column.

(7) *Accelerator pedal.* The accelerator pedal, located to the right of the brake pedal, controls the engine speed through linkage to the throttle lever, on the carburetor.

(8) *Ignition switch and starter button.* Both the ignition switch and the starter button are located on the right side of the instrument panel. They are used to turn the current on or off, control the flow of current to the instrument panel gages, and allow the current to flow to



flow to the starter motor solenoid. The ignition switch must be turned to the right when the engine is to be started. Pressing the starter button allows current to flow to energize the starter solenoid for cranking the engine.

(9) *Choke control.* The choke control, located on the left side of the instrument panel, controls the carburetor choke plate. Pull the choke knob all the way out when starting a cold engine. Push the choke knob in gradually as the engine warms up.

*b. Instruments.*

(1) *Oil pressure gage.* The oil pressure gage indicates the pressure of the oil circulating through the engine. The indicator should register approximately 25 to 30 psi under normal idling conditions. A cold engine will normally have a higher oil pressure than an engine that is warm.

**Caution: Always check the oil pressure gage immediately after starting the engine. If the gage does not register or oil pressure is low, stop the engine immediately and check the lubrication**

**system to determine the cause of the low pressure.**

(2) *Ammeter.* The ammeter is connected into the main battery circuit and indicates whether the battery is charging or discharging. A needle deflection to the charge side indicates the battery is being charged by the alternator and a deflection to the discharge side indicates the battery is discharging.

(3) *Coolant temperature gage.* The coolant temperature gage indicates temperature of coolant circulating in the engine cooling system. If the engine is overheating, stop the engine and refer to table 2-1.

(4) *Fuel gage.* The fuel gage is located on the left side of the instrument panel. The fuel gage indicates the amount of fuel remaining in the fuel tank. The gage is divided into four equal graduations from empty (E) to full (F).

(5) *Hour meter.* The hour meter is located on the right side of the instrument panel. The meter reads up to 9,999.9 hours and then repeats.

#### Section IV. OPERATION UNDER USUAL CONDITIONS

##### 2-6. General

a. The instructions in this section are for the information and guidance of personnel responsible for operation of the F60-24PS-180 Forklift Truck.

b. The operator must know how to perform every operation of which the F60-24PS-180 Forklift Truck is capable. This section contains instructions on starting and stopping the truck, on operation of the truck, and on coordinating the basic motions to perform the specific tasks for which the equipment is designed. Since nearly every job presents a different problem, the operator may have to vary given procedures to fit the individual job.

##### 2-7. Starting

a. Before starting the truck, refer to paragraph 3-4 and perform the required daily preventive maintenance services.

b. Start the engine in the following manner.

(1) Place the shifting lever in the neutral position.

(2) Turn the ignition switch to the ON position.

(3) Partially depress the accelerator pedal (approximately 1/3 of its travel).

(4) Pull the choke knob all the way out when the engine is cold.

(5) Turn the ignition switch all the way to the right to the start position. Press the starter button to crank the engine. Release the starter button as soon as the engine starts.

**Caution: Do not operate the starter motor for more than 30 seconds at a time. If the engine does not start, allow the starter motor to cool for approximately two minutes before attempting to again start the engine.**

(6) After starting the engine, gradually push in the choke control knob as the engine warms up. It is not necessary to use the choke during normal operation or when starting a warm engine.

**Note. Excessive use of the choke dilutes the crankcase oil causing wear of piston rings and cylinder walls. It is recommended that engine oil be changed more frequently in cold weather because of this condition.**

##### 2-8. Stopping

a. Gradually apply pressure to the foot brake pedal, depressing the inching pedal when required to prevent the engine from stalling before stopping.

**Warning: Always lower the forks to the ground before leaving the lift truck unattended.**

b. When parking, pull the hand brake lever back, place the shift lever in neutral, and lower the forks to the floor.

c. Allow the engine to idle for a few minutes before turning off the ignition switch. This will allow the engine to cool off gradually. After idling for a short while, turn the ignition switch to the OFF position.

## 2-9. Operation of Equipment

### a. Shifting Operation-Power Shift.

(1) With the engine idling, release the parking brake.

(2) Place the directional lever in either forward or reverse position and accelerate the truck. Refer to figure 2-2 for the shift pattern and the lift and tilt pattern.

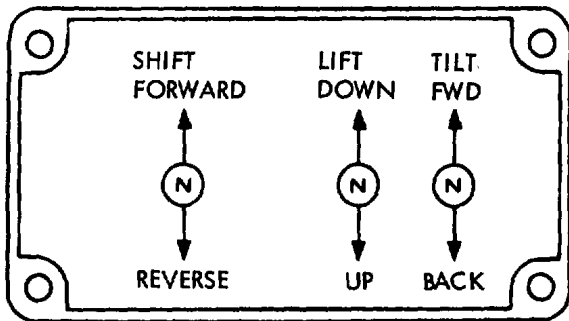

ME 3930-624-12/2-2

Figure 2-2. Shift lift, and tilt pattern.

(3) To change direction, always come to a complete stop and then place the power shift lever in the desired position.

### b. Lifting and Lowering Operation.

(1) Pull the lift lever back to lift, or push the lever forward to lower. Refer to figure 2-2. When the lever is released it will automatically return to the neutral position.

(2) A slight acceleration of the engine and a gradual movement of the lift lever from the neutral to the lift position will produce a slow lifting action.

(3) Accelerating the engine and pulling the lever back as far as possible increases the speed of lift.

(4) When the forks are raised to the desired height, release the lever smoothly to the neutral position, and the forks will hold at this point.

**Warning:** After reaching the desired height, tilt the forks back to prevent the load from sliding off.

(5) The lowering speed is controlled by the weight of the load and the position of the control lever. Push the lift lever slightly forward to lower the load slowly. To lower the load quickly, push the lever forward as far as possible. Release the lever slowly to the neutral position as the load reaches the desired level.

**Caution:** Do not release the lift lever suddenly while lowering the load, as this will cause severe shock.

### c. Tilting Operation.

(1) To tilt the mast backward, accelerate the engine slightly and pull back on the tilt lever. To tilt the mast forward, accelerate the engine slightly and push the tilt lever forward. Refer to figure 2-2.

(2) The speed of the engine and the size of the orifices in the control valve tilt plunger control the speed of tilt. When the mast reaches the desired angle of tilt, release the lever smoothly to the neutral position. The mast will hold at this angle.

**Warning:** Use care when tilting the mast to prevent dumping the load.

**d. Inching Control.** This operation is done with a pedal operated by the left foot. Refer to figure 2-1 for location. Changing the pedal stroke varies the oil pressure in the clutch pack and applies the service brakes so that an "inching" operation can be performed without losing full engine power. The lower the pedal is depressed, the slower the truck will travel.

## Section V. OPERATION UNDER UNUSUAL CONDITIONS

### 2-10. Operation in Extreme Cold

**a. General.** If the truck is to be operated in extreme cold weather temperatures, certain precautions must be taken to assure continued normal operation. The following sub-paragraphs detail checks to be made to be certain the truck is capable of operating at these temperatures.

**b. Cooling System.** Check the cooling system for correct antifreeze solution for the lowest temperature expected. Refer to table 2-1. Carefully inspect the cooling system and correct or report any leaks.

**c. Battery.** Keep the battery full charged to prevent freezing. If water is added to the battery, run the engine

at least one hour to mix the electrolyte solution.

**d. Fuel System.** Keep the fuel tank full at all times. If condensation forms in the fuel tank, the fuel tank must be drained and cleaned. Refer to paragraph 4-21.

**e. Lubrication.** Lubricate the truck according to the current lubrication order.

**f. Operation.** Start the engine (para 2-7) and allow it to reach normal operating temperature before applying a load.

(1) If mud and snow collects and freezes on any of the moving parts while the truck is idle, apply heat to thaw the frozen material before attempting to operate the truck.

(2) Operate the hydraulic units with care until the units have reached a temperature to enable them to operate normally.

(3) Check all truck operations to be sure all components are in operating condition.

*g. Parking.*

(1) Park the truck on high ground if possible. Prepare a footing of planks or brush if necessary to keep the wheels from freezing to the ground. Chock the wheels and set the parking brake. Place blocks under the forks to prevent the forks from freezing to the ground.

(2) Clean all mud, snow, and ice from the truck to prevent freezing. Park the truck under cover, or cover the truck with a tarpaulin if possible. Insure that the ends of the tarpaulin will not freeze to the ground.

## **2-11. Operation in Extreme Heat**

*a. General.* Continuous operation of the truck in high temperatures may cause the truck to overheat. Frequently observe the engine temperature and stop the truck for a cooling off period whenever necessary.

*b. Cooling System.* Make frequent inspections of the fan and radiator. Keep the coolant level one inch from the top of the radiator; use care when opening radiator cap. Check the radiator fins for accumulation of dust, sand, and insects which could block the cooling passages.

(1) Formation of scale and rust in the cooling system occurs more rapidly in extremely high temperatures. Change the antifreeze each year to keep the corrosion inhibitor at full strength. (Refer to TB 750-651).

(2) If necessary, flush the cooling system periodically to keep the passages clear. Avoid the use of water with high alkali content which increases scale and rust formations.

*c. Battery.* Check the level of the electrolyte daily. Keep the electrolyte above the plates to prevent damage to the battery. Use a slightly weaker electrolyte solution in hot climates. Dilute 1.280 specific gravity electrolyte as issued, to 1.200 to 1.240 specific gravity reading at full charge. Recharge the battery at 1.160 specific gravity. The battery will self discharge at a higher rate if left standing for long periods of time at high temperatures.

*d. Fuel System.* Service the fuel system as directed in paragraph 3-4, Preventive Maintenance. Check the fuel for water content before filling the fuel tank. High temperatures and cooling off cause condensation in storage drums.

*e. Lubrication.* Lubricate as specified in the current lubrication order.

*f. Parking.*

(1) Do not park the truck in the sun for long

periods of time. When practical, park the truck under cover to protect it from sun, sand, and dust.

(2) Cover the truck with a tarpaulin if suitable shelter is not available. Protect the engine compartment from sand accumulation.

(3) In hot, damp climates, corrosive action will occur on all parts of the truck and will be accelerated during the rainy season. Rust and paint blisters will appear on metal surfaces and fungus growth on other surfaces.

(4) Protect all unfinished exposed metal surfaces with a film of preservative. Protect cables and terminals with ignition insulation compound. Apply paint or suitable rust preventive to damaged surfaces to protect from rust and corrosion.

## **2-12. Operation in Dusty or Sandy Areas**

*a. General.* Operation of the truck may cause dust in almost any area. However, when operating in dusty or sandy areas additional precautions must be taken.

*b. Cooling System.* Keep the cooling system fins and cooling areas clean. Blow out with compressed air, if possible, whenever necessary.

*c. Fuel System.* Use care when servicing the fuel system to prevent dust and sand from entering the tank.

*d. Air System.* Service the air cleaner at frequent intervals. Prevent dust and sand from entering engine parts and compartment as much as possible.

*e. Lubrication.* Lubricate the truck in accordance with the current lubrication order. Lubricate and perform services at much shorter intervals than normal. Clean all lubrication fittings before applying lubricant. Sand mixed with a lubricant becomes very abrasive and increases wear on parts.

*f. Parking.* Protect the truck as much as possible. Park the truck under cover or protect with tarpaulins.

## **2-13. Operation Under Rainy or Humid Conditions**

*a. General.* Operation under rainy or humid conditions is similar to that in extreme heat.

*b. Preservation.* Keep all exposed bare metal surfaces coated with a preservative. Pay particular attention to damaged or unpainted surfaces. Cover all paint cracks and chip marks as soon as possible to prevent corrosive effects.

## **2-14. Operation in Salt Water Areas**

*a. General.* The corrosive effect of salt water and salt water spray is very extensive. When operating in salt water areas, observe the following precautions.

*b. Preservation.*

(1) When exposed to salt water, rinse with fresh water, and dry the truck thoroughly as soon as possible.

(2) Keep all exposed surfaces coated with preservative. Pay particular attention to damaged paint surfaces.

(3) Keep all painted surfaces in good repair.

(4) Lubricate the truck as prescribed in the current lubrication order. Shorten lubricating intervals for parts subject to exposure to salt water.

## **2-15. Operation at High Altitudes**

*a. General.* Operation of the truck at high altitudes will reduce the operating efficiency of the engine.

Clean and service the air cleaner more often for maximum air intake for engine operation.

*b. Cooling System.* Check the engine operating temperature for evidence of overheating. The pressure cap on the radiator must make a perfect seal to maintain coolant pressure in the system.

OPERATOR'S MAINTENANCE INSTRUCTIONS

Section I. LUBRICATION INSTRUCTIONS

3-1. General

This section contains lubrication instructions which are supplemental to and not specifically covered in the lubrication order.

3-2. Detailed Lubrication Information

a. *General.* Keep all lubricants in closed containers and store in a clean dry place away from external heat. Allow no dust, dirt, or other foreign material to mix with the lubricants.

b. *Cleaning.* Keep all external parts not requiring lubrication clean of lubricants. Before lubricating the equipment, wipe all lubrication points free of dirt and grease. Clean all lubrication points after lubrication to prevent accumulation of foreign matter.

c. *Points of Lubrication.* Service the points of lubrication at proper intervals. Refer to the current lubrication order (LO 10-3930-624-12).

d. *Crankcase Oil Level.*

(1) The crankcase oil level must be checked every ten hours.

(2) In order to obtain an accurate measurement of the level of oil in the crankcase, the engine must be stopped and the vehicle parked on level ground.

(3) After stopping the engine, allow at least five minutes for the oil to drain back into the oil pan.

(4) Withdraw the dipstick, which is located on the left side of the engine (fig. 3-1) and wipe clean. Reinsert all the way and then remove for a true reading. Add oil as necessary to bring the oil level to the FULL mark on the dipstick.

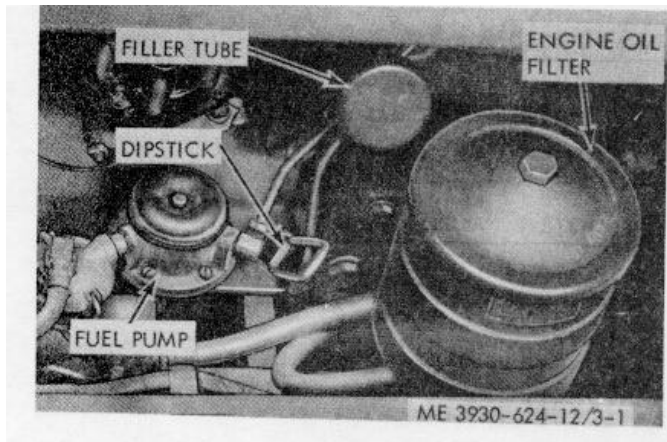

Figure 3-1. Checking crankcase oil level.

(5) The oil may require changing more frequently than usual because of contamination by dilution. Sludge formation will increase under cold weather operating conditions.

(6) Refer to the current lubrication order for the correct oil to use.

e. *Air Cleaner.*

(1) Daily, check the amount and condition of the oil in the air cleaner cup. If the oil level is low, or if the oil is dirty, service the air cleaner.

(2) To service the air cleaner proceed as follows:

(a) Loosen and remove wingnut and washer.

(b) Separate the air cleaner top from the lower body as shown in figure 3-2.

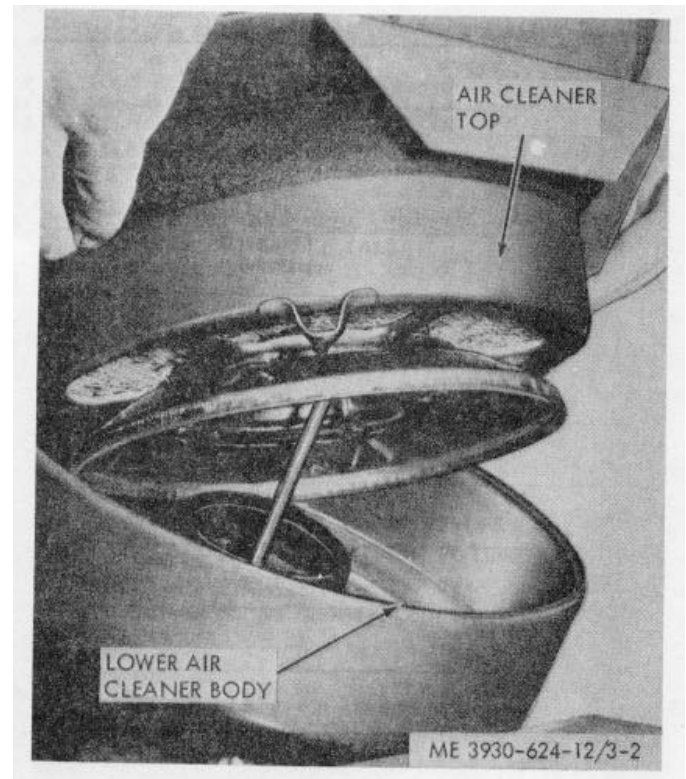

Figure 3-2. Air cleaner.

(c) Empty the oil from the cup and clean with solvent; dry thoroughly.

(d) Fill the cup to the indicated level with fresh oil of the same type and quality as used in the engine crankcase.

(e) Position the air cleaner in place, secure with the washer and wingnut.

*f. Power-Shift Transmission.*

(1) Remove the plug in the floor plate to gain access to the dipstick located on the right side of the transmission case. Refer to figure 3-3.

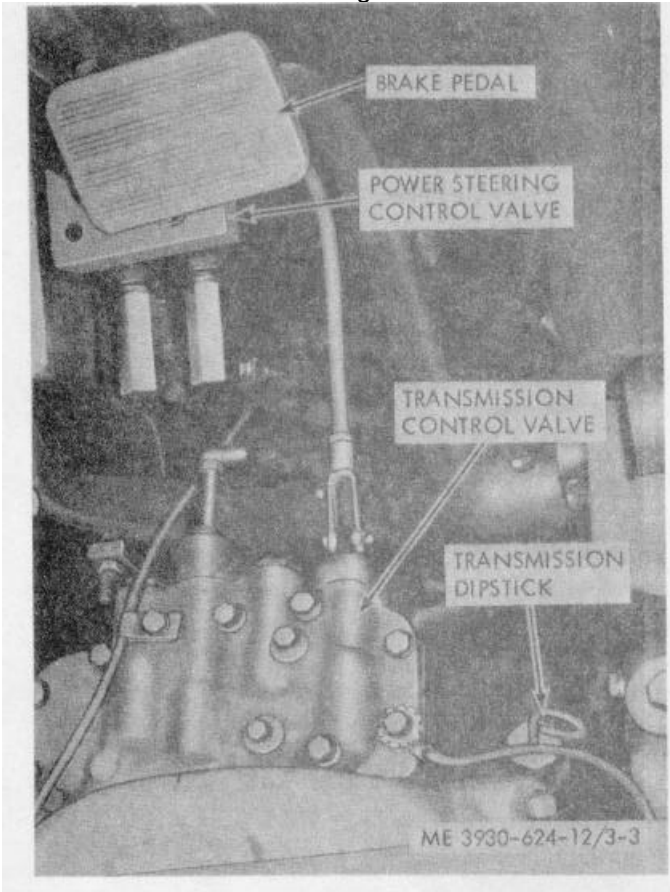

Figure 3-3. Transmission dipstick.

(2) With the engine running, and transmission in neutral, withdraw the dipstick and check the oil level.

(3) Add oil through the dipstick opening, if necessary, to raise the level to the FULL mark on the dipstick. Refer to the current lubrication order for the correct transmission fluid to use.

(4) Install the plug in the floor plate.

*g. Fuel Tank Servicing.* Check the fuel gage. Add fuel as necessary to bring the level up to full.

*h. Radiator.* Check coolant level. Level should be within one inch of the top.

*i. Batteries.*

*Note.* Overfilling the battery can cause poor performance or early failure due to loss of electrolyte.

(1) Check the level of the electrolyte regularly. Add distilled water if necessary.

(2) Keep the top of the battery clean.

(3) Refer to TM 9-6140-200-15 for more specific servicing information

## Section II. PREVENTIVE MAINTENANCE CHECKS AND SERVICES

### 3-3. General

To insure that the truck is ready for operation at all times, it must be inspected systematically so that defects may be discovered and corrected before they result in serious damage or failure. The necessary preventive maintenance checks and services to be performed are listed and described in paragraph 3-4. Defects discovered during operation of the unit will be noted for future correction to be made as soon as the operation has ceased. Stop the operation immediately if a deficiency is noted during operation which would

damage the equipment if operation were continued. All deficiencies and shortcomings will be recorded together with the corrective action taken on DA Form 2404 (Equipment Inspector and Maintenance Worksheet) at the earliest possible opportunity.

### 3-4. Preventive Maintenance

Refer to table 3-1 for preventive maintenance services. Item numbers indicate the sequence of minimum requirements.

Table 3-1. Preventive Maintenance Checks and Services

Operator Maintenance Category			Daily Schedule (or weekly)		
Interval and sequence No.			Item to be inspected	Procedure	Paragraph reference
Before operation	During operation	After operation			
1	.....	10	Fuel tank .....	Add fuel as required	Para 3-2-g
2	.....	.....	Transmission.....	Check oil level lweeklyl	Para 3-2-f
3	.....	.....	Radiator .....	Check coolant level. Level within one inch of top	Para 3-2-h
4	.....	.....	Battery.....	Remove corrosion. Check electrolyte level Fill as required (weekly)	Para 3-2-i
5	.....	.....	Air cleaner .....	Refill oil reservoir to level mark	Para 3-2-e
6	.....	11	Engine crankcase .....	Check oil level and replenish as necessary	Para 3-2-d
7	.....	.....	Fire extinguisher .....	Check for broken seal and correct pressure	
8	.....	.....	Horn .....	Check for operation	
9	.....	.....	Hydraulic reservoir.....	Check oil level. Add oil as required (weekly)	
10	.....	.....	Instruments and controls .....	Inspect for damage and insecure mountings Check for proper indication	
11	.....	.....	Leaks, general .....	Check under truck for leaks. Report to organizational maintenance	
12	.....	.....	Lights .....	Check for operation	
.....	13	.....	Brakes.....	Check parking brake and service brake to assure safe operation	
.....	14	.....	Controls.....	Check that controls perform as required	
.....	15	.....	Instruments .....	Check that all instruments indicate within required ranges	
.....	16	.....	Unusual noises and vibration .....	Listen for unusual noises and check for excessive vibration. If present, shut off engine and report to organizational maintenance	

**Section III. TROUBLESHOOTING**

**3-5. General**

Table 3-2 provides information useful in diagnosing and correcting unsatisfactory operation or failure of the truck and its components. Each trouble symptom stated is followed by a list of probable causes. The possible

remedy recommended is described opposite the probable cause. Any trouble beyond the scope of operator maintenance shall be reported to organizational maintenance personnel.

Table 3-2. Troubleshooting

Malfuction	Probable cause	Corrective action
1. Engine cranks but does not start.	Insufficient fuel.	Check fuel level in tank.
2. Engine hard to start.	a. Insufficient fuel or incorrect grade.	a. Check tank and fill with correct grade fuel.
	b. Insufficient air to engine.	b. Service air cleaner (para 3-2 e ).
3. Engine stops suddenly.	Fuel tank empty.	Fill tank.
4. Engine overheats.	Coolant level low.	Check and fill radiator.
5. Engine power low.	Engine does not receive sufficient air.	Service air cleaner (para 3-2 e ).
	Insufficient air to cylinders.	Service air cleaner (para 3-2 e ).
6. Engine emits black smoke in exhaust.		
7. Engine oil pressure low.	a. Crankcase oil level low.	a. Fill crankcase.
	b. Oil leak.	b. Check oil lines.
	Clogged air cleaner.	Service.
8. Air intake system not operating properly.		
9. Truck will not move.	Transmission oil level low.	Check and replenish.
10. Truck does not steer properly.	Hydraulic oil level low.	Check and replenish.
11. Forks do not lift or lower.	a. Low hydraulic oil.	a. Check and replenish.
	b. Clogged hydraulic filter.	b. Service hydraulic filter.

## Section IV. MAINTENANCE OF THE ENGINE

### 3-6. General

The engine is a conventional valve-in-head, four cycle, liquid cooled, internal combustion type. A gear type oil pump supplies lubricating oil to the moving parts of the engine.

### 3-7. Servicing

Check the crankcase oil level daily as described in paragraph 3-2d

## Section V. MAINTENANCE OF THE AIR CLEANER

### 3-8. General

The oil bath type air cleaner is mounted on the left side of the engine and is connected to the carburetor by a flexible hose. It prevents harmful dust and foreign particles from entering the carburetor and engine. Air enters the air cleaner and passes through an oil bath before entering the carburetor.

**Caution:** Never run the engine with the air cleaner removed.

### 3-9. Servicing

The air cleaner should be serviced at the recommended intervals or more frequently under dusty conditions. Refer to paragraph 3-2 (e) for a servicing procedure. The air cleaner and connections should always be tightly secured to prevent dust or dirt entry.

## Section VI. MAINTENANCE OF THE FUEL TANK

### 3-10. General

The capacity of the fuel tank is 8.3 gallons. Always clean the area around the fuel tank before refilling. Fill the tank at the end of each operating period to keep condensation to a minimum.

### 3-11. Servicing

At periodic intervals remove the filler assembly from the top of the tank and clean the strainer. Also remove drain plug from the bottom of the tank and allow sediment or water to drain out.

## Section VII. MAINTENANCE OF THE RADIATOR

### 3-12. General

The radiator is of the fin and tube type, utilizing a pressure filler cap which maintains a pressure of approximately 4 psi. An overflow tube is provided on the radiator to allow the escape of coolant and / or pressure when the pressure raises above the limit of the pressure cap.

### 3-13. Servicing

**Warning:** Provide adequate ventilation of the working area during the cleaning operation to avoid possible toxic effects of the cleaning spray. Never use gasoline, fuel oil, or kerosene to clean the radiator.

a. Remove the mounting bolts which secure the grille to the counterweight and remove the grille.

b. Clean the radiator fins with an air blast carrying a grease solvent, such as oleum spirits, directed at the radiator core and passing through the grille side.

c. Reinstall the radiator grille in the reverse order of removal.

d. When servicing the system for warm weather operation, add a rust inhibitor to the water. Follow the directions on the container.



## CHAPTER 4

### ORGANIZATIONAL MAINTENANCE INSTRUCTIONS

#### Section I. SERVICE UPON RECEIPT OF MATERIAL

##### 4-1. Inspecting and Servicing Equipment

###### a. Inspection.

(1) Check the exterior of the forklift truck for loosely mounted or damaged components. Tighten loose mounting bolts. Report any damage to the proper authority.

(2) Check the truck for leaks. Tighten leaking hoses or fittings.

(3) Check all engine components for secure mounting and for damage that occurred during shipping. Tighten loose mounting bolts. Report any damage to the proper authority.

###### b. Service.

(1) Remove all protective tape and any preservatives which were used to protect the equipment during shipment.

(2) Check the coolant level in the radiator; if necessary, add coolant to the required level. Refer to table 2-1 for antifreeze mixture requirements.

(3) Check the level of the engine lubricating oil; if the level is at or below the ADD mark on the dipstick add oil until the level reaches the FULL mark on the dipstick.

(4) Check the oil level in the hydraulic reservoir; add oil until the level reaches the FULL mark on the dipstick.

(5) Check the oil level in the transmission and add as necessary, refer to paragraph 3-2 f.

##### 4-2. Installation of Separately Packed Components

a. Remove the packages containing the battery electrolyte that are taped to the engine compartment.

b. Remove the caps from the battery. Fill the battery cells to the tops of the split rings. using the electrolyte that was packed separately.

c. Connect the battery cables to the corresponding battery posts as shown in figure 4-1.

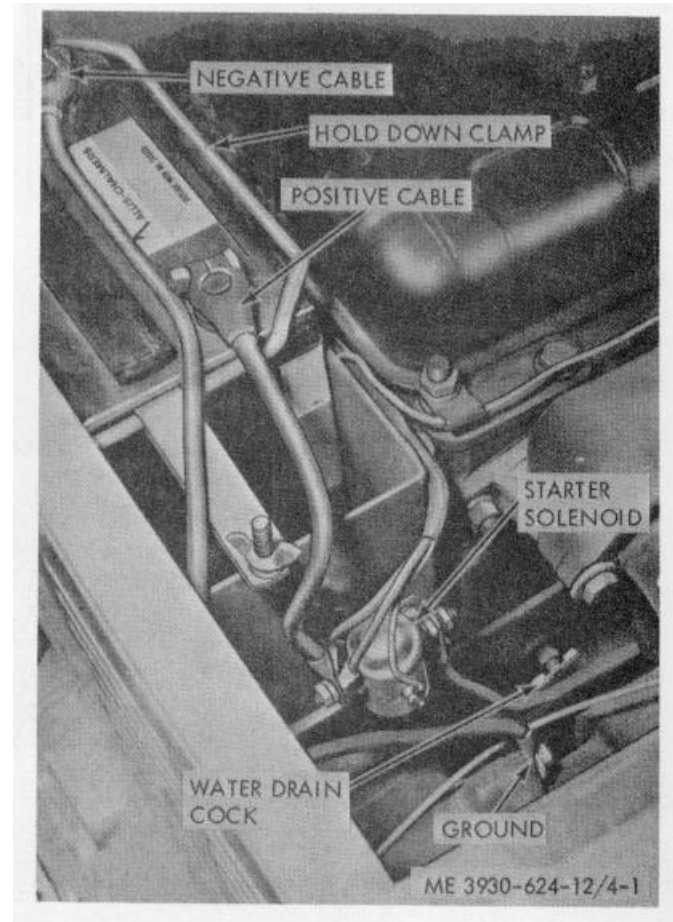

Figure 4-1. Battery connections.

d. Remove the fire extinguisher from the package. Open the clamps and remove the extinguisher from the bracket. Mount the bracket behind the driver's seat and on top of the engine compartment. Fasten the extinguisher to the bracket.

e. Since this is a mobile piece of equipment, no additional installation or setting-up instructions are required.

#### Section II. REPAIR PARTS, SPECIAL TOOLS, AND EQUIPMENT

##### 4-3. Tools and Equipment

No basic issue tools or repair parts are issued or authorized for use on the truck.

##### 4-4. Special Tools and Equipment

No special tools or equipment are required to perform the organizational maintenance on the truck.

**4-5. Maintenance Repair Parts**  
Organizational maintenance repair parts for the

truck are listed and illustrated in TM 10-3930-624-20P (When printed).

### Section III. LUBRICATION INSTRUCTIONS

**4-6. General**

This section contains lubrication instructions to supplement the lubrication order.

*b. Cleaning.* Keep all external parts which do not require lubrication clean of lubricants. Before and after lubricating, clean all lubrication points.

**4-7. Detailed Instructions**

*a. General.* Keep all lubricants in closed containers and store in a clean dry place away from external heat. Prevent dust, dirt, and other foreign material from contaminating the lubricant.

*c. Points of Lubrication.* Service the points of lubrication at the required intervals. Refer to the current lubrication order.

### Section IV. PREVENTIVE MAINTENANCE CHECKS AND SERVICES

**4-8. General**

The truck must be systematically and periodically inspected for defects to ensure that it is ready for operation at all times. Defects should be corrected before they result in serious damage or failure.

**4-9 Preventive Maintenance Services**

Refer to table 4-1 for preventive maintenance services. Item numbers indicate a sequence for performing preventive checks and services.

### Section V. TROUBLESHOOTING

**4-10. General**

Table 4-2 provides information for diagnosing and correcting improper operation or failure of the truck components. Each trouble symptom is followed by a list

of probable causes and possible remedies. Refer any trouble beyond the scope of organizational maintenance to direct support maintenance.

Table 4-1. Preventive Maintenance Checks and Services

Operator Maintenance Category		Schedule per 250 hours of operation	
Item number	Item to be inspected	Procedure	Reference
1	Alternator and fan belt tension	Check that belt can be deflected ½ inch inward midway between the fan pulley and the alternator pulley.	
2	Cooling system	Check level and antifreeze qualities of coolant. Check for damage or leaking hoses.	para 4-28
3	Fuel filter	Service fuel filter	para 4-23
4	Fuel lines and fittings	Check for leaks.	
5	PCV valve	Clean PCV valve and fittings.	para 4-16
6	Battery and cables	Check electrolyte level. Check for cracked or leaking battery, loose or corroded terminals, loose cables. Correct faulty conditions.	para-4-39
7	Hydraulic reservoir breather	Replace if clogged or dirty.	Para 4-63
8	Hydraulic system	Check for leaks, damaged lines and fittings, and low fluid level. Correct any deficiencies.	para 4-61
9	Brake pedal free travel	Adjust if brake pedal does not have ½ inch free travel.	para 4-53
10	Brake application	Correct deficiencies if brake application is spongy, ineffective, or nonexistent.	para 4-51
11	Tires	Check for embedded glass and metal, cuts, gouges, and other damage.	para 4-55
12	Intake and exhaust manifold	Check for cracks, leaking gasket, and insecure mounting.	para 4-18
*13	Exhaust system	Check for cracked or damaged exhaust pipes or muffler. Replace damaged parts.	
*14	Engine tuneup and test	Check engine compression and timing.	para 4-15
*15	Electrical system	Check and adjust electrical components including alternator, voltage regulator, starter, and distributor.	para 4-33 para 4-36
16	Battery	Check and service battery.	

\*To be accomplished after every 500 hours of operation instead of every 250 hours of operation.

Table 4-2. Troubleshooting

Malfunction	Probable cause	Corrective action
1 Engine will not start (No spark Ammeter shows no discharge Zero reading with ignition switch on.)	<ul style="list-style-type: none"> <li>a. Ignition switch defective</li> <li>b. Ignition primary wires or starting motor cables broken or connections loose.</li> <li>c. Ignition coil primary winding open.</li> <li>d. Distributor points dirty</li> <li>e. Distributor points not closing</li> <li>f. Loose or corroded ground or battery cable connections</li> </ul>	<ul style="list-style-type: none"> <li>a. Replace switch (para 4-40).</li> <li>b. Repair or replace and tighten.</li> <li>c. Replace coil (para 4-38).</li> <li>d. Clean and adjust points (para 4-36)</li> <li>e. Adjust or replace points (para 4-36)</li> <li>f. Remove clean reinstall tighten cable clamps (para 4-39).</li> </ul>
2 Engine will not start (Ammeter shows abnormal discharge with ignition switch on.)	<ul style="list-style-type: none"> <li>a. Short-circuited wire between ammeter and ignition switch.</li> </ul>	<ul style="list-style-type: none"> <li>a. Repair or replace wire.</li> </ul>
3 Engine will not start (weak spark or no spark)	<ul style="list-style-type: none"> <li>b. Short-circuited primary winding</li> <li>a. Distributor points not opening</li> <li>b. Distributor points pitted or burned.</li> <li>c. Distributor capacitor weak</li> <li>d. Ignition coil weak</li> <li>e. Primary wire connections loose</li> <li>f. High-tension wires, spark plug wires, or distributor cap wet.</li> <li>g. High-tension wires, spark plug wires, or distributor cap damaged.</li> <li>h. Distributor cap or rotor burned or broken</li> <li>i. Spark plug gaps incorrect</li> <li>j. Short-circuited secondary circuit in coil.</li> </ul>	<ul style="list-style-type: none"> <li>b. Replace coil (para 4-38).</li> <li>a. Clean or replace and adjust points (para 4-36).</li> <li>b. Clean or replace (para 4-36).</li> <li>c. Replace capacitor (para 4-36).</li> <li>d. Replace coil (para 4-38).</li> <li>e. Tighten connections.</li> <li>f. Dry Thoroughly</li> <li>g. Replace defective parts.</li> <li>h. Replace defective parts (para 4-36).</li> <li>i. Reset gaps (para 4-37).</li> <li>j. Replace coil (para 4-38)</li> </ul>
4 Engine will not start (good spark)	<ul style="list-style-type: none"> <li>a. Fuel tank empty</li> <li>b. Dirt or water in carburetor or float stuck.</li> <li>c. Carburetor and engine flooded by excessive use of choke</li> <li>d. Fuel not reaching carburetor</li> <li>e. Dirt in fuel lines or tank</li> <li>f. Fuel line pinched</li> <li>g. Ignition wires incorrectly installed in distributor cap.</li> <li>h. Ignition timing incorrect</li> <li>i. Fuel filter clogged</li> <li>j. Fuel pump not pumping</li> <li>k. Choke improperly adjusted</li> </ul>	<ul style="list-style-type: none"> <li>a. Refill tank.</li> <li>b. Replace carburetor (para 4-19).</li> <li>c. Depress accelerator pedal fully, and crank engine with starting motor; when engine starts, release throttle and leave choke control in.</li> <li>d. Inspect for damaged or leaky lines or air leak into line between, tank and fuel pump.</li> <li>e. Disconnect lines drain tank and blow out lines (para 4-21).</li> <li>f. Repair or replace line.</li> <li>g. Install wires correctly</li> <li>h. Reset timing (para 4-36)</li> <li>i. Replace filter (para 4-23)</li> <li>j. Replace pump (para 4-20)</li> <li>k. Adjust choke (para 4-19)</li> </ul>
5 Engine backfires	<ul style="list-style-type: none"> <li>a. Ignition out of time</li> <li>b. Spark plug wires incorrectly installed in distributor cap or at spark plugs.</li> <li>c. Distributor cap cracked or shorted.</li> </ul>	<ul style="list-style-type: none"> <li>a. Reset timing (para 4-36)</li> <li>b. Install wires correctly.</li> <li>c. Replace cap (para 4-36)</li> </ul>
6 Engine operates erratically	<ul style="list-style-type: none"> <li>a. Improper ignition timing</li> <li>b. Spark plug wires incorrectly installed in distributor cap.</li> <li>c. Dirt or water in carburetor</li> <li>d. Carburetor improperly adjusted.</li> <li>e. Fuel pump pressure low.</li> <li>f. Fuel filter clogged.</li> </ul>	<ul style="list-style-type: none"> <li>a. Reset timing (para 4-36)</li> <li>b. Install wires correctly</li> <li>c. Drain carburetor: clean fuel system</li> <li>d. Adjust carburetor (para 4-19)</li> <li>e. Replace pump (para 4-20)</li> <li>f. Replace filter (para 4-23)</li> </ul>

Table 4-2. Troubleshooting - Continued

Malfunction	Probable cause	Corrective action
6. Engine operates erratically -Continued	<ul style="list-style-type: none"> <li><i>g.</i> Partly clogged or pinched fuel lines.</li> <li><i>h.</i> Intake manifold leak.</li> </ul>	<ul style="list-style-type: none"> <li><i>g.</i> Clean and repair lines (para 4-21).</li> <li><i>h.</i> Inspect gaskets and tighten manifold stud nuts (para 4-18).</li> </ul>
7. Engine stalls on idle.	<ul style="list-style-type: none"> <li><i>i.</i> Distributor cap cracked or shorted.</li> <li><i>a.</i> Carburetor throttle valve closes too far or idle mixture incorrect.</li> <li><i>b.</i> Carburetor choke remaining closed.</li> <li><i>c.</i> Dirt or water in idler passages of carburetor.</li> <li><i>d.</i> Air leak at intake manifold.</li> </ul>	<ul style="list-style-type: none"> <li><i>i.</i> Replace cap (para 4-36).</li> <li><i>a.</i> Adjust carburetor (para 4-19).</li> <li><i>b.</i> Adjust choke cable (para 4-19).</li> <li><i>c.</i> Replace carburetor (para 4-19).</li> <li><i>d.</i> Tighten manifold stud nuts or replace gaskets (para 4-18).</li> </ul>
8. Engine( misfires on one or more cylinder.	<ul style="list-style-type: none"> <li><i>e.</i> Spark plugs defective, gaps incorrect.</li> <li><i>f.</i> Ignition timing early.</li> <li><i>a.</i> Dirty spark plugs.</li> <li><i>b.</i> Cracked spark plug porcelain.</li> <li><i>c.</i> Spark plug wires grounded.</li> <li><i>d.</i> Spark plug wires incorrectly installed in cap or at spark plugs.</li> <li><i>e.</i> Distributor cap or rotor burned or broken.</li> </ul>	<ul style="list-style-type: none"> <li><i>e.</i> Clean or replace spark plugs; set gap clearance (para 4-37).</li> <li><i>f.</i> Reset timing (para 4-36).</li> <li><i>a.</i> Clean, adjust. or replace plugs (para 4-37).</li> <li><i>b.</i> Replace spark plug (para 4-37).</li> <li><i>c.</i> Replace wires.</li> <li><i>d.</i> Install wires correctly.</li> <li><i>e.</i> Replace defective parts (para 4-36).</li> </ul>
9. Engine not idle properly.	<ul style="list-style-type: none"> <li><i>a.</i> Spark plugs dirty or gaps too close.</li> <li><i>b.</i> Ignition timing incorrect.</li> <li><i>c.</i> Carburetor idle circuit requires adjusting.</li> </ul>	<ul style="list-style-type: none"> <li><i>a.</i> Clean and adjust spark plugs (para 4-37).</li> <li><i>b.</i> Reset timing (para 4-36).</li> <li><i>c.</i> Adjust carburetor (para 4-19).</li> </ul>
10. Engine misses at high speeds.	<ul style="list-style-type: none"> <li><i>a.</i> Spark plugs dirty, defective, or incorrectly gapped.</li> <li><i>b.</i> Ignition coil or capacitor weak.</li> <li><i>c.</i> Distributor points sticking, dirty, or improperly adjusted.</li> <li><i>d.</i> Distributor rotor or cap cracked or burned.</li> <li><i>e.</i> Leaking high-tension or spark plug wires; cracked insulation.</li> <li><i>f.</i> Carburetor choke not adjusted.</li> <li><i>g.</i> Defective carburetor accelerating pump system, dirt in metering jets, or incorrect float level.</li> <li><i>h.</i> Fuel pump defective, causing lack of fuel.</li> <li><i>i.</i> Air cleaner dirty.</li> <li><i>j.</i> Fuel filter clogged.</li> <li><i>k.</i> Weak distributor breaker arm spring.</li> <li><i>l.</i> Excessive play in distributor shaft bearing.</li> </ul>	<ul style="list-style-type: none"> <li><i>a.</i> Clean and set or replace spark plugs (para 4-37).</li> <li><i>b.</i> Replace defective parts (para 4-36).</li> <li><i>c.</i> Clean adjust or replace points (para 4-36).</li> <li><i>d.</i> Replace defective parts para 4-36).</li> <li><i>e.</i> Replace defective parts.</li> <li><i>f.</i> Adjust choke (para 4-19).</li> <li><i>g.</i> Replace carburetor (para 4-19).</li> <li><i>h.</i> Replace fuel pump (para 4-20).</li> <li><i>i.</i> Clean air cleaner and refill oil cup (para 4-25).</li> <li><i>j.</i> Remove and clean strainer (para 4-23).</li> <li><i>k.</i> Replace point set (para 4-36).</li> <li><i>l.</i> Replace distributor (para 4-36).</li> </ul>
11. Engine pings .	<ul style="list-style-type: none"> <li><i>a.</i> Ignition timing early.</li> <li><i>b.</i> Distributor automatic spark Advance stuck in advance position or spring broken.</li> </ul>	<ul style="list-style-type: none"> <li><i>a.</i> Reset timing (para 4-36).</li> <li><i>b.</i> Replace distributor (para 4-36).</li> </ul>
12. Engine, lacks power	<ul style="list-style-type: none"> <li><i>c.</i> Incorrect fuel.</li> <li><i>a.</i> Ignition timing late.</li> <li><i>b.</i> Incorrect fuel.</li> <li><i>c.</i> Engine running cold.</li> <li><i>d.</i> Insufficient oil or improper grade of oil.</li> </ul>	<ul style="list-style-type: none"> <li><i>c.</i> Drain; use correct fuel (para 4-21).</li> <li><i>a.</i> Reset timing para 4-36).</li> <li><i>b.</i> Drain; use correct fuel para 4-21).</li> <li><i>c.</i> Test thermostat. In cold weather. cover air intake under driver's seat.</li> <li><i>d.</i> Lubricate in accordance with current lubrication order.</li> </ul>

Table 4-2. Troubleshooting - Continued

Malfunction	Probable cause	Corrective action
12. Engine lacks power -Continued	<ul style="list-style-type: none"> <li>e. Oil system failure</li> <li>f. Air cleaner dirty</li> <li>g. Spark plug gaps too wide</li> <li>h. Choke partially closed, or throttle not opening fully</li> <li>i. Exhaust pipe, muffler, or tailpipe obstructed</li> <li>j. Improper tappet adjustment</li> <li>k. Lack of fuel</li> </ul>	<ul style="list-style-type: none"> <li>e. Report to direct support or general support maintenance personnel.</li> <li>f. Clean air cleaner change oil in cup (para 4-25)</li> <li>g. Reset gaps (para 4-37).</li> <li>h. Adjust choke accelerator pedal and governor linkage (para 4-19 and 4-24).</li> <li>i. Remove obstructions or replace parts (para 4-26).</li> <li>j. Adjust tappets (para 4-1).</li> <li>k. Clean filter inspect fuel pump. inspect carburetor for water or dirt, and replace if necessary.</li> </ul>
13. High engine oil consumption.	<ul style="list-style-type: none"> <li>a. High engine speeds.</li> <li>b. Improper grade of oil or diluted oil.</li> <li>c. Overheating of engine causing thinning of oil.</li> </ul>	<ul style="list-style-type: none"> <li>a. Adjust governor (para 4-22).</li> <li>b. Use new oil of proper grade..</li> <li>c. See "Engine overheats." item 24 below.</li> </ul>
14. Low engine oil pressure.	<ul style="list-style-type: none"> <li>a. Insufficient oil supply.</li> <li>b. Improper grade of oil or diluted oil foaming at high speeds.</li> <li>c. Oil too heavy.</li> </ul>	<ul style="list-style-type: none"> <li>a. Fill crankcase to prescribed level.</li> <li>b. Change oil inspect crankcase ventilator, and inspect for water in oil.</li> <li>c. Change to prosper grade oil. Refer to lubrication order.</li> </ul>
15. Poor engine compression.	Incorrect tappet adjustment.	Adjust tappets (para 4-15).
16. Fuel does not reach carburetor.	<ul style="list-style-type: none"> <li>a. No fuel in fuel tank.</li> <li>b. Fuel filter clogged.</li> <li>c. Fuel line air leak between tank and fuel pump.</li> <li>d. Fuel line clogged.</li> <li>e. Fuel tank cap vent clogged.</li> <li>f. Fuel pump defective.</li> </ul>	<ul style="list-style-type: none"> <li>a. Fill fuel tank.</li> <li>b. Replace filter cartridge (para 4-23)</li> <li>c. Repair or replace line (para 4-20)</li> <li>d. Disconnect and blow out lines.</li> <li>e. Clean vent.</li> <li>f. Replace pump (para 4-20).</li> </ul>
17. Fuel reaches carburetor, but does	<ul style="list-style-type: none"> <li>a. Choke not closing. not reach cylinders.</li> <li>b. Fuel passage in carburetor clogged.</li> <li>c. Carburetor float valve stuck closed.</li> </ul>	<ul style="list-style-type: none"> <li>a. Adjust choke control (para 4-19)</li> <li>b. Replace carburetor (para 4-19).</li> <li>c. Replace carburetor (para 4-19)</li> </ul>
18. High fuel consumption.	<ul style="list-style-type: none"> <li>a. Correct adjustment of carburetor.</li> <li>b. Vehicle overloaded.</li> <li>c. High engine speeds.</li> <li>d. Air cleaner clogged.</li> <li>e. Carburetor float level too high; accelerating pump not properly adjusted.</li> <li>f. Fuel line leaks.</li> <li>g. Carburetor parts worn or broken.</li> <li>h. Fuel pump pressure too high or diaphragm leaking.</li> <li>i. Engine running cold.</li> <li>j. Ignition incorrectly timed.</li> <li>k. Spark advance stuck.</li> <li>l. Leaking fuel filter bowl gasket.</li> <li>m. Choke partially closed.</li> <li>n. Engine idling too fast.</li> <li>o. Spark plugs dirty.</li> <li>p. Weak coil.</li> <li>q. Clogged muffler or bent exhaust pipe.</li> </ul>	<ul style="list-style-type: none"> <li>a. Adjust carburetor (para 4-19)</li> <li>b. Reduce loads to specified minimum capacity.</li> <li>c. Readjust governor (para 4-22).</li> <li>d. Clean air cleaner and change oil in cup (para 4-25).</li> <li>e. Replace carburetor (para 4-19)</li> <li>f. Correct leaks; replace lines (para 4-21).</li> <li>g. Replace carburetor (para 4-19)</li> <li>h. Replace fuel pump (para 4-20)</li> <li>i. Inspect thermostat I para 4-29). In cold weather, cover air intake under driver heat.</li> <li>j. Reset timing (para 4-36)</li> <li>k. Replace distributor (para 4-36)</li> <li>l. Replace gasket (para 4-23).</li> <li>m. Adjust choke control (para 4-19).</li> <li>n. Adjust carburetor idle speed adjust screw (para 4-19).</li> <li>o. Clean and gap or replace spark plugs (para 4-37).</li> <li>p. Replace coil (para 4-38).</li> <li>q. Remove obstruction replace defective parts (para 4-26).</li> </ul>

Table 4-2. Troubleshooting

Malfunction	Probable cause	Corrective action
19. Low fuel pressure	<ul style="list-style-type: none"> <li>a. Air leak in fuel lines</li> <li>b. Fuel pump defective, diaphragm broken; valves leaking, linkage worn.</li> <li>c. Fuel lines clogged</li> </ul>	<ul style="list-style-type: none"> <li>a. Tighten connections; replace lines if damaged (para 4-20).</li> <li>b. Replace fuel pump (para 4-20).</li> <li>c. Clean or replace lines (para 4-21).</li> </ul>
20. Engine idles to fast	<ul style="list-style-type: none"> <li>a. Improper carburetor throttle stop adjustment</li> <li>b. Accelerator linkage sticking</li> <li>c. Accelerator linkage return spring weak.</li> </ul>	<ul style="list-style-type: none"> <li>a. Adjust idle speed adjusting screw (para 4-19).</li> <li>b. Free and lubricate linkage (para 4-24).</li> <li>c. Replace spring (para 4-24).</li> </ul>
21. Fuel gage does not register	<ul style="list-style-type: none"> <li>a. Loose wire connection at instrument panel or tank unit.</li> <li>b. Fuel gage in instrument panel inoperative.</li> </ul>	<ul style="list-style-type: none"> <li>a. Tighten connections.</li> <li>b. Replace unit (para 4-40).</li> </ul>
22. Loss of coolant	<ul style="list-style-type: none"> <li>a. Loose hose connections</li> <li>b. Damaged or deteriorated hose</li> <li>c. Leaking radiator</li> <li>d. Defective pressure cap</li> </ul>	<ul style="list-style-type: none"> <li>a. Tighten hose connections.</li> <li>b. Replace hoses (para 4-28).</li> <li>c. Replace radiator (para 4-28).</li> <li>d. Replace cap or gasket.</li> </ul>
23. Engine too cool during operation	<ul style="list-style-type: none"> <li>a. Thermostat sticking</li> <li>b. Low air temperature</li> </ul>	<ul style="list-style-type: none"> <li>a. Replace thermostat and gasket (para 4-29).</li> <li>b. In cold weather cover an air intake under driver's seat.</li> </ul>
24. Engine overheats	<ul style="list-style-type: none"> <li>a. Airflow through radiator core restricted</li> <li>b. Coolant level low</li> <li>c. Clogged radiator core</li> <li>d. Thermostat stuck</li> <li>e. Damaged or deteriorated hose or fan belt</li> <li>f. Radiator or water pump leaking</li> <li>g. Loose fan belt</li> <li>h. Ignition timing incorrect</li> <li>i. Damaged muffler; bent or clogged</li> <li>j. Insufficient oil or improper grade of oil.</li> <li>k. Air cleaner restricted</li> <li>l. Water pump impeller broken</li> <li>m. Timing incorrect</li> </ul>	<ul style="list-style-type: none"> <li>a. Clean radiator core from counterweight side with compressed air or water (para 4-28).</li> <li>b. Fill radiator to proper level (para 4-28).</li> <li>c. Clean by flushing radiator (para 4-28).</li> <li>d. Replace thermostat (para 4-29).</li> <li>e. Replace defective parts (para 4-31).</li> <li>f. Replace defective parts (para 4-30).</li> <li>g. Adjust fan belt tension (para 4-31).</li> <li>h. Reset timing (para 4-36).</li> <li>i. Replace defective parts (para 4-26).</li> <li>j. Refer to lubrication order.</li> <li>k. Clean air cleaner and change oil in cup (para 4-25).</li> <li>l. Replace pump (para 4-30).</li> <li>m. Reset timing (para 4-36).</li> </ul>
25. Starting motor cranks engine slowly.	<ul style="list-style-type: none"> <li>a. Engine oil too heavy</li> <li>b. Weak battery</li> <li>c. Battery cell shorted</li> <li>d. Battery connections corroded, broken, or loose</li> <li>e. Starting motor defective</li> </ul>	<ul style="list-style-type: none"> <li>a. Change to proper grade oil.</li> <li>b. Recharge or replace battery (para 4-39).</li> <li>c. Replace battery (para 4-39).</li> <li>d. Clean and tighten or replace cables.</li> <li>e. Replace starting motor (para 4-35).</li> </ul>
26. Starting motor does not crank engine.	<ul style="list-style-type: none"> <li>a. Engine oil too heavy.</li> <li>b. Starting motor, solenoid or cables defective; loose connections.</li> <li>c. Starting motor pinion gear jammed in flywheel drive gear.</li> <li>d. Dirty drive mechanism.</li> <li>e. Faulty starter relay.</li> <li>f. Faulty ignition switch.</li> <li>g. Faulty neutral starting switch.</li> </ul>	<ul style="list-style-type: none"> <li>a. Change to proper grade oil.</li> <li>b. Replace defective starting motor (para 4-35) or tighten loose connections.</li> <li>c. Replace starting motor (para 4-35).</li> <li>d. Clean and lubricate drive mechanism.</li> <li>e. Replace starter relay (para 4-40).</li> <li>f. Replace switch (para 4-40).</li> <li>g. Replace switch (fig. 4-40).</li> </ul>

Table 4-2. Troubleshooting - Continued

Malfunction	Probable cause	Corrective action
27. Starting motor operates, but fails to crank engine when switch is engaged.	a. Starting motor gear not engaging flywheel	a. Replace starting motor (para 4-35).
	b. Starting motor or drive gear defective	b. Replace starting motor (para 4-35).
28. No alternator output	a. Regulator defective	a. Adjust or replace regulator (para 4-34).
	b. Alternator defective	b. Replace alternator (para 4-33).
29. Low or fluctuating alternator output.	a. Loose fan belt	a. Adjust belt (para 4-31).
	b. Loose or dirty connections in charging circuit.	b. Clean and tighten connections.
	c. Defective alternator	c. Replace alternator (para 4-33).
	d. Defective regulator	d. Adjust or replace regulator (para 4-34).
30. Excessive alternator output.	a. Defective alternator.	a. Replace alternator (para 4-33).
	b. Defective regulator.	b. Adjust or replace regulator (para 4-34).
31. Alternator noisy	a. Loose pulley or alternator mounting.	a. Tighten.
	b. Defective bearings or rotor rubbing on stator windings.	b. Replace alternator (para 4-33).
32. Battery discharged	a. Battery solution level low	a. Add distilled water to bring level to splittings in battery; inspect for cracked case.
	b. Short in battery cell	b. Replace battery (para 4-39).
	c. Alternator not charging	c. See "No alternator output" or "Low or fluctuating alternator output", items 28 and 29 above.
	d. Loose or dirty connections; broken cables	d. Clean and tighten connections; replace cables (para 4-39).
	e. Excessive use of starting motor	e. Tune up engine; charge battery.
	f. Idle battery or excessive use of lights with engine at idle	f. Recharge or replace battery (para 4-39). Use lights sparingly.
	g. Short circuits	g. Replace defective wiring.
33. Lights do not light	a. Switch not fully on	a. Turn switch on fully.
	b. Loose or dirty connections, broken wire	b. Clean and tighten; replace or repair wire or terminal.
	c. Wiring circuit short circuited or open	c. Correct short circuit or replace defective parts.
	d. Light burned out	d. Replace light (para 4-41).
	e. Defective switch	e. Replace switch (para 4-40).
34. Lights dim	a. Loose or dirty connections	a. Clean and tighten connections.
	b. Wiring short circuited	b. Correct short circuit or replace defective parts.
	c. Defective switch	c. Replace switch (para 4-40).
	d. Weak battery	d. Recharge or replace battery (para 4-39). Replace wire.
35. Horn sounds continuously	Short circuit in wiring between horn and horn button.	
36. Horn will not operate.	a. Horn fuse blown.	a. Replace fuse.
	b. Loose or dirty connection.	b. Clean and tighten connections.
	c. Open circuit.	c. Repair or replace wire.
37. Continuous drive axle noise.	a. Unevenly worn tires.	a. Replace wheels (para 4-55).
	b. Improperly adjusted wheel bearing.	b. Adjust bearings (para 4-56).
	c. Lack of lubricant.	c. Fill to correct level. Lubricate.
38. Steering is difficult.	Lack of lubrication.	
39. Truck wanders or weaves.	a. Loose wheel bearings.	a. Adjust wheel bearings (para 4-56).
	b. Steering gear mounting bolts loose.	b. Tighten mounting bolts.
40. Shimmy or wobble at low speeds.	Loose wheel bearings.	Adjust wheel bearings (para 4-56).
41. Vehicle pulls to one side.	a. Odd size or new and old tires on opposite wheels.	a. Match tires.
	b. Improper toe-in, camber, or caster.	b. Adjust to proper specifications (refer to para 4-58).
	c. Tight wheel bearings.	c. Adjust. Lubricate wheel bearings (para 4-56).

Table 4-2. Troubleshooting - Continued

Malfunction	Probable cause	Corrective action
42. Brakes drag	<ul style="list-style-type: none"> <li>a. Improper pedal adjustment</li> <li>b. Brakeshoe anchor pin tight in shoe</li> <li>c. Brakeshoe return spring broken or weak.</li> <li>d. Loose or damaged wheel bearings</li> </ul>	<ul style="list-style-type: none"> <li>a. Adjust brake pedal free travel (para 4-53).</li> <li>b. Free pin and lubricate lightly.</li> <li>c. Replace spring (para 4-51)</li> <li>d. Adjust or replace wheel bearings (para 4-56).</li> </ul>
43. Brakes grab	<ul style="list-style-type: none"> <li>e. Brake backing plate loose</li> <li>a. Grease on linings</li> <li>b. Dirt imbedded in lining</li> <li>c. Drums scored or rough</li> </ul>	<ul style="list-style-type: none"> <li>e. Tighten plate para 4-51).</li> <li>a. Correct grease leakage; clean or install new shoes and lining assemblies (para 4-51).</li> <li>b. Clean lining with wire brush.</li> <li>c. Replace drum and brakeshoe and lining assemblies (para 4-51).</li> </ul>
44. Brake locked	<ul style="list-style-type: none"> <li>a. Brake pedal lacking free travel</li> <li>b. Brakes frozen to drums (cold Weather).</li> </ul>	<ul style="list-style-type: none"> <li>a. Adjust pedal free travel (para 4-53).</li> <li>b. Break loose by driving vehicle.</li> </ul>
45. Brake noisy or chatters	<ul style="list-style-type: none"> <li>a. Brake lining worn</li> <li>b. Grease on linings</li> <li>c. Dirt embedded in linings</li> <li>d. Improper or loose linings</li> </ul>	<ul style="list-style-type: none"> <li>a. Replace shoe and lining assemblies (para 4-51).</li> <li>b. Correct leakage; clean or replace shoe and lining assemblies (para 4-51).</li> <li>c. Clean lining with wire brush.</li> <li>d. Replace shoe and lining assemblies (para 4-51).</li> </ul>
46. Excessive brake pedal travel	<ul style="list-style-type: none"> <li>e. Brakeshoe or drum distorted</li> <li>a. Lining worn</li> <li>b. Pedal free travel improperly adjusted.</li> </ul>	<ul style="list-style-type: none"> <li>e. Replace (para 4-51).</li> <li>a. Replace shoe and lining assemblies (para 4-51).</li> <li>b. Adjust free travel (para 4-53).</li> </ul>
47. Excessive brake pedal pressure	<ul style="list-style-type: none"> <li>a. Insufficient fluid in master necessary to actuate brakes</li> <li>b. Grease on linings; worn or glazed lining</li> <li>c. Warped brakeshoes or defective brake linings</li> <li>d. Brakedrum scored or distorted</li> </ul>	<ul style="list-style-type: none"> <li>a. Fill master cylinder to within 1/4 cylinder inch of the top (para 4-52).</li> <li>b. Correct grease leakage; clean tip and replace shoe and lining assemblies (para 4-51).</li> <li>c. Replace shoe and lining assemblies (para 4-51).</li> <li>d. Repair or replace drum (para 4-51).</li> </ul>
48. Wheel wobble	<ul style="list-style-type: none"> <li>a. Wheel bent</li> <li>b. Wheel loose on hub</li> <li>c. Wheel bearings not adjusted</li> </ul>	<ul style="list-style-type: none"> <li>a. Inspect mounting on hub, spindles, and drive axle; replace defective wheel or mounting (para 4-55).</li> <li>b. Tighten nuts or bolts.</li> <li>c. Adjust; lubricate wheel bearings (para 4-56).</li> </ul>
49. Forks do not lift to maximum height.	Hydraulic oil level low	Fill to correct level.
50. Truck will not move in either direction	<ul style="list-style-type: none"> <li>a. Parking brake not released</li> <li>b. Transmission oil level low</li> </ul>	<ul style="list-style-type: none"> <li>a. Release brake.</li> <li>b. Fill to correct level.</li> </ul>
51. Truck moves slowly in either direction at wide open throttle	<ul style="list-style-type: none"> <li>a. Oil level low</li> <li>b. Brakes dragging</li> </ul>	<ul style="list-style-type: none"> <li>a. Fill to correct level.</li> <li>b. Refer to "Brakes drag" item 42 above.</li> </ul>
52. Transmission overheating	<ul style="list-style-type: none"> <li>a. Oil level low</li> <li>b. Brakes dragging</li> <li>c. Plugged radiator</li> </ul>	<ul style="list-style-type: none"> <li>a. Fill to correct level.</li> <li>b. Refer to "Brakes drag" item 42 above.</li> <li>e. Flush radiator (para 4-28).</li> </ul>

**Section VI. RADIO INTERFERENCE SUPPRESSION**

**4-11. General**

Essentially, suppression is attained by providing a low resistance path to ground for stray currents. The method

used includes high resistance carbon wires, grounding the frame with bonding straps, and using resistor type spark plugs. (Refer to TM 11-4831.



#### **4-12. Radio Interference Suppression Components**

*a. Primary Suppression Components.* The primary suppression components are those whose primary function is to suppress radio interference.

*b. Secondary Suppression Components.* These components have radio interference functions which are incidental or secondary to their primary functions.

#### **4-13. Replacement of Suppression Components**

Replace the radio interference suppression components by replacing the spark plugs or ignition

wires as necessary.

#### **4-14. Testing of Radio Interference Suppression Components**

Test and inspect the spark plugs as outlined in paragraph 4-37. Test the high resistance carbon ignition wire by connecting an ohmmeter to each end of the wire. If the meter reads an infinite resistance, the wires have an open or break and should be replaced.

### **Section VII. MAINTENANCE OF THE ENGINE**

#### **4-15. Engine Test and Adjustments**

*a. General.* Proper clearance (lash) between rocker arms and end of intake and exhaust valve stems is very important. Insufficient valve clearance will cause loss of compression, misfiring, and will eventually cause burning of valves and valve seats. Excessive valve clearance will cause faulty engine operation, valve tappet noise, and rapid wear on valve operating mechanism.

##### *b. Compression Testing.*

(1) Be certain the ignition switch is in the OFF position.

(2) Remove the high tension wire from the center of the distributor.

(3) Remove the spark plug wires, and remove all spark plugs.

(4) Put the transmission in NEUTRAL.

(5) Insert compression test gage in spark plug hole.

(6) Crank engine for at least four compression strokes. Note reading on first full stroke as well as on final stroke. Gage should read 125 psi, plus or minus 10 psi between cylinders.

(7) Repeat the same procedure for all six cylinders; each cylinder should be tested the same number of compression strokes to assure accurate readings.

(8) Replace all spark plugs and wires in the proper positions; replace the high tension lead on the distributor.

##### *c. Adjustment.*

(1) Remove rocker arm cover, gasket, and high tension wire from ignition coil. Discard the gasket.

(2) Starting with number one cylinder, crank engine with starter motor until both valves are closed and the push rods are in their lowest position on the cam.

(3) Check the clearance between rocker arms and valve stems with a 0.015 inch feeler gage. It should pass between the rocker arm and corresponding valve stem with a slight amount of drag when valve lash is properly adjusted.

(4) Adjust each valve by turning the adjusting screw clockwise to decrease the clearance or counterclockwise to increase the clearance, as necessary. Refer to figure 4-2.

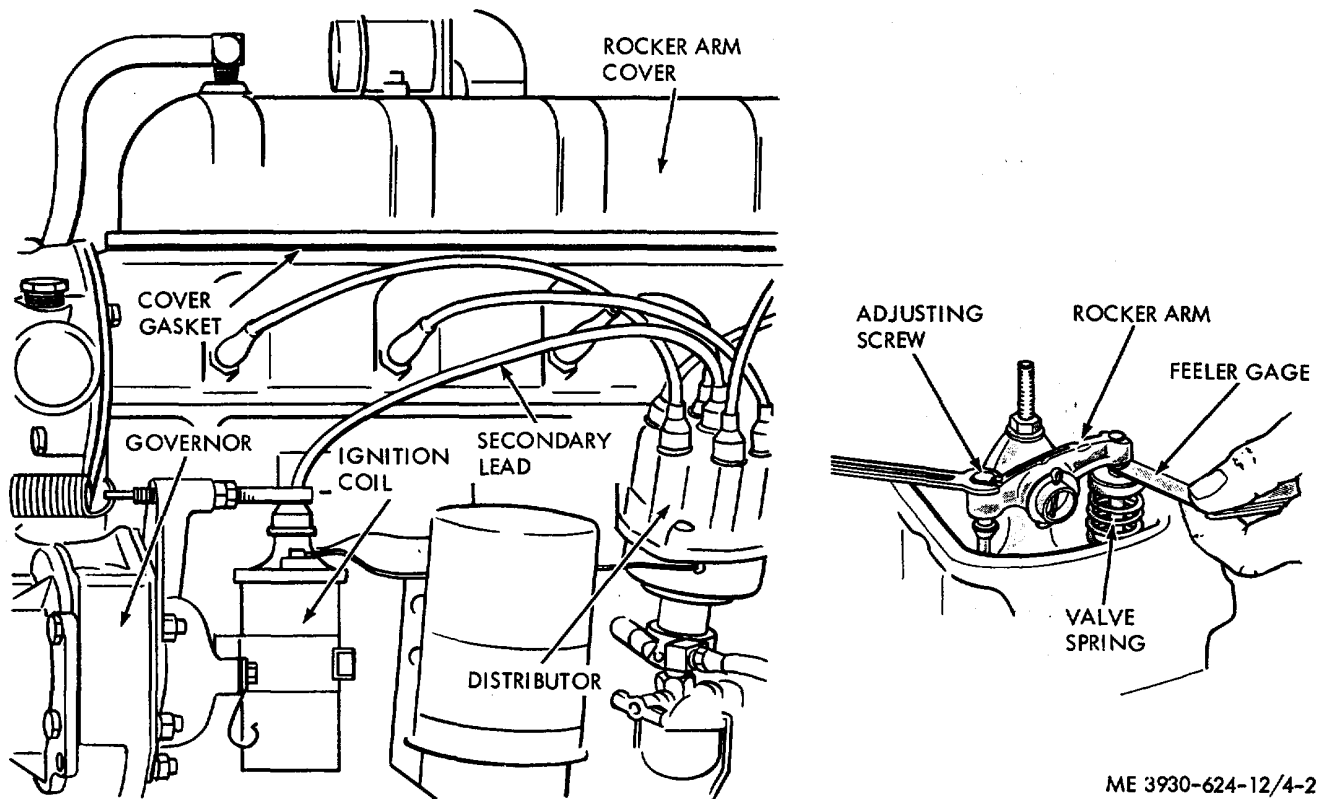

ME 3930-624-12/4-2

Figure 4-2. Valve clearance adjustment.

(5) Repeat above steps on the valves for the other cylinders. Make sure the engine is cranked so valves are closed and push rods are at lowest position on cam lobes.

(6) Connect high tension wire to ignition coil and start the engine.

(7) Operate engine until it reaches a normal operating temperature of 1650 F and then stop engine. Thoroughly clean rocker arm cover and surrounding area.

(8) When the engine is hot and idling, slowly move a 0.010 inch feeler gage for the intake valve, and a 0.012 for the exhaust valve, between the rocker arm

and valve stem. If clearance is correct, a slight drag will be felt, followed by a momentary tightening which prevents movement of the feeler gage.

(9) Check all valves in the same manner as outlined in step 8. Install the rocker arm cover and a new gasket.

#### 4-16. Crankcase Ventilation

##### a. Replacement.

(1) Remove screw (11), washer (12), and clamp (13) securing breather tube (5) to engine block (fig. 4-3).

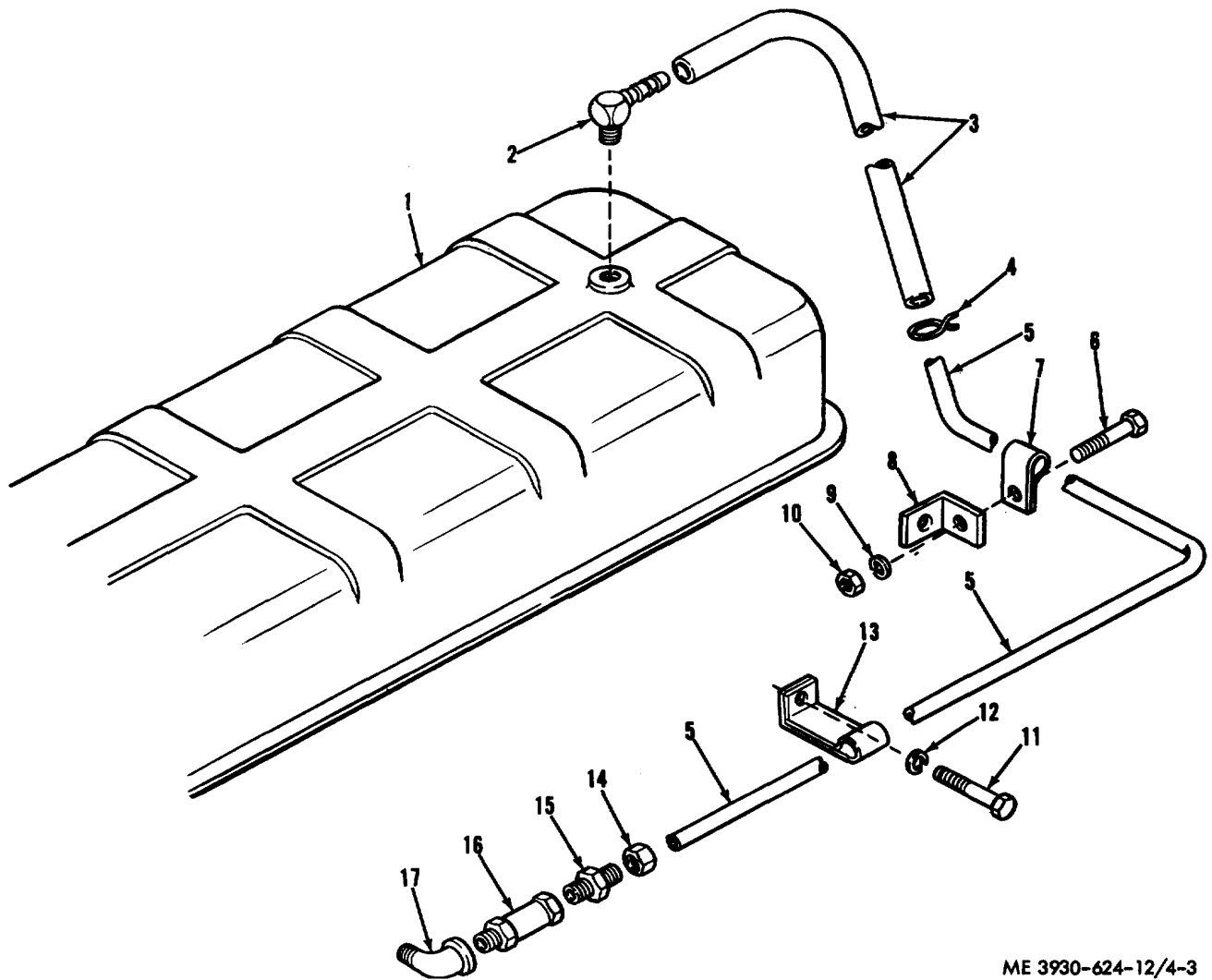

ME 3930-624-12/4-3

1. Rocker arm cover
2. Elbow
3. Hose
4. Clamp
5. Tube
6. Screw
7. Clamp
8. Clamp
9. Washer

10. Nut
11. Screw
12. Washer
13. Clamp
14. Nut
15. Connector
16. Valve
17. Elbow

Figure 4-3. Crankcase ventilation.

(2) Remove screw (6), washer (9), nut (10) and clamp (7) securing tube to tube clamp (8).

(3) Remove clamp (4) securing the hose (3) to the tube (5) and disconnect the male connector (15), valve (16), and elbow (17). Remove the tube (5).

(4) Unscrew the elbow (2) from the rocker arm cover (1) and remove the hose (3).

(5) Install the tube by reversing the removal procedure.

*b. Servicing.*

(1) Remove the tube and hose and check for restrictions. Clean with solvent.

(2) Disconnect the PCV valve. Clean with solvent and replace.

#### 4-17. Oil Filter Assembly

a. *General.* The lubricating oil filter is a cartridge type. The filter is located on the right side of the engine near the flywheel housing (fig. 4-4). A new cartridge with gasket must be installed after each 250 hours of operation, or more often if conditions warrant.

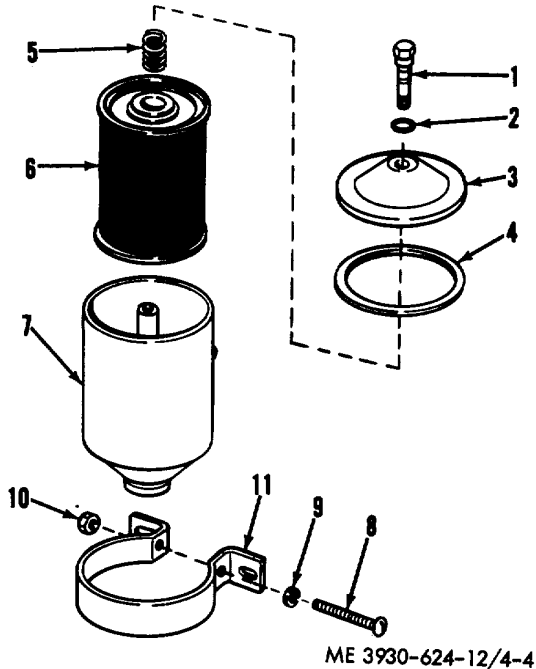

- |             |              |
|-------------|--------------|
| 1. Bolt     | 7 Case       |
| 2. Washer   | 8 Screw      |
| 3 Cover     | 9 Lockwasher |
| 4. Gasket   | 10 Nut       |
| 5. Spring   | 11 Strap     |
| 6 Cartridge |              |

Figure 4-4. Oil filter.

b. *Removal.* (Refer to fig. 4-4.)

(1) Thoroughly clean the filter and the surrounding area.

(2) Remove the bolt (1) and washer (2) securing the cover (3) to the case assembly. Discard the cover gasket (4).

(3) Remove the spring (5) and the cartridge (6); discard the cartridge.

(4) Disconnect the inlet and outlet lines from the filter case (7). Remove the screw (8), lockwasher (9), nut (10), and strap (11) securing the case. (5) Clean any dirt or sediment that has accumulated in the filter base.

c. *Installation.*

(1) Place a new gasket in the cover and lightly coat the new gasket with clean engine oil.

(2) Install a new cartridge in the filter housing.

**Note. Do not overtighten the cover bolt.**

(3) Place the cover on the filter housing and secure it with the bolt.

(4) Start the engine and check for oil leakage between the filter housing and the cover. Stop the engine and check the oil level. Add oil if necessary to bring the level up to the "FULL" mark on the dipstick.

#### 4-18. Manifold.

a. *Removal.*

(1) Remove carburetor from the manifold (para 4-19).

(2) Remove the self-locking bolts and washers which secure the exhaust pipe to the exhaust manifold flange.

(3) Disconnect the fitting which secures the positive crankcase ventilation valve to the bottom of the manifold.

(4) Remove the self-locking nuts and washers which connect the manifold to the cylinder head and lift the manifold off the studs (fig. 4-6).

(5) Remove the gaskets from manifold ports.

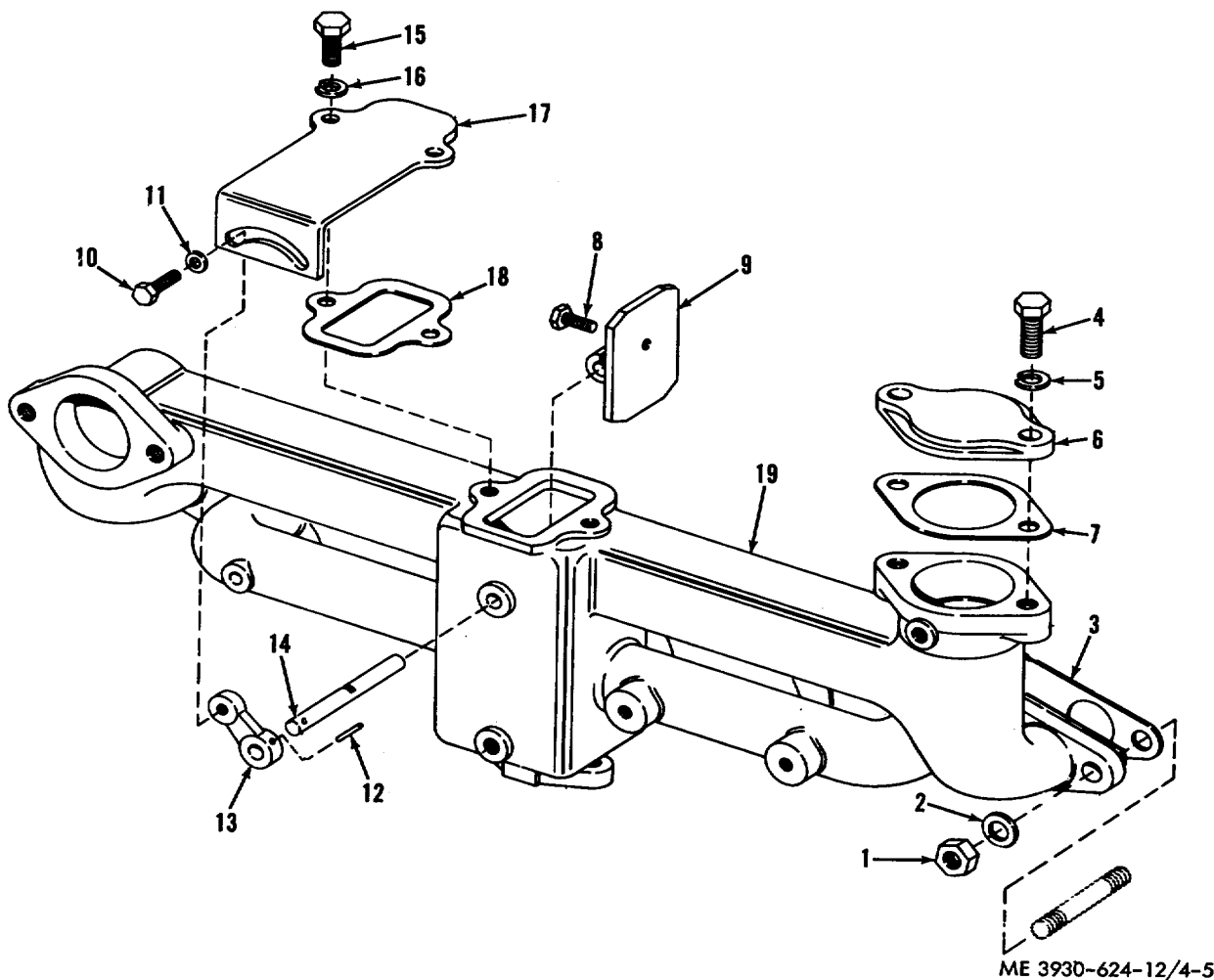

- |                 |                |
|-----------------|----------------|
| 1. Nut          | 11. Washer     |
| 2. Washer       | 12. Pin        |
| 3. Gasket       | 13. Lever      |
| 4. Bolt         | 14. Rod        |
| 5. Washer       | 15. Bolt       |
| 6. Gasket cover | 16. Lockwasher |
| 7. Gasket       | 17. Plate      |
| 8. Bolt         | 18. Gasket     |
| 9. Plate        | 19. Manifold   |
| 10. Bolt        |                |

Figure 4-5. Manifold.

*b. Inspection.*

(1) The manifold should be checked for racks and warpage. If cracked, replace. To check , warpage, lay a straightedge across the manifold parts. If warped, refer the problem to direct lippott maintenance for machining or replace.

(2) Remove excessive (carbon deposits with a scraper and wire brush.

(3) Manifold gaskets must be in good condition to prevent entry of dirt and to maintain correct fuel-air ratio of intake mixture.

*c. Installation.*

(1) Install new gasket (3, fig. 4-5) on manifold.

(2) Position the manifold on the studs and install the washers and self-locking nuts (1 and 2). Tighten the nuts to a torque of 32 to 35 ft.-lbs.

(3) Install the carburetor (para 4-19

Connect the fuel inlet line (6, fig. 4-7), governor control rod, choke control cable, and accelerator rod.

(4) Connect the exhaust pipe to the exhaust manifold flange, and install the carburetor air cleaner hose.

(5) Install the air cleaner, seat and seat deck, and side panels. Open the fuel shut-off valve at the fuel tank.

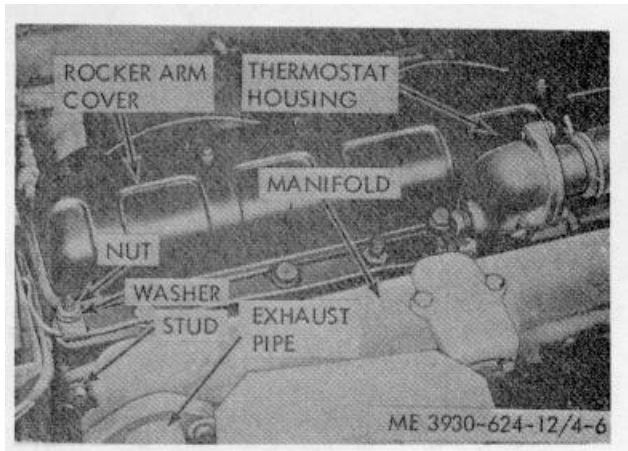

Figure 4-6. Manifold mounting

## Section VIII. MAINTENANCE OF THE FUEL SYSTEM

### 4-19. Carburetor

a. *Adjustment.* (fig. 4-7.)

**Note.** Before making any adjustments. Warm the engine up to normal operating temperature.

(1) *General.* Proper mixture of fuel and air is controlled by a fixed jet and an adjustable idle fuel jet (14). The throttle stop screw (2) is preset to maintain the correct engine idle speed. Adjustments are properly set during manufacture.

(2) *Throttle stop screw adjustment.*

(a) Turn the throttle stop screw (2) in against the stop to hold the throttle slightly open (fig. 4-7).

(b) After idle fuel adjustment is made, adjust the stop screw to obtain an idle speed between 500 and 550 rpm.

KEY to Fig. 4-7:

1. Accelerator rod
2. Throttle stop screw
3. Nuts and lockwashers
4. Idle adjusting jet
5. Governor control rod
6. Fuel inlet line
7. Throttle lever
8. Bowl drain plug
9. Swivel connection
10. Choke control bracket
11. Choke control cable

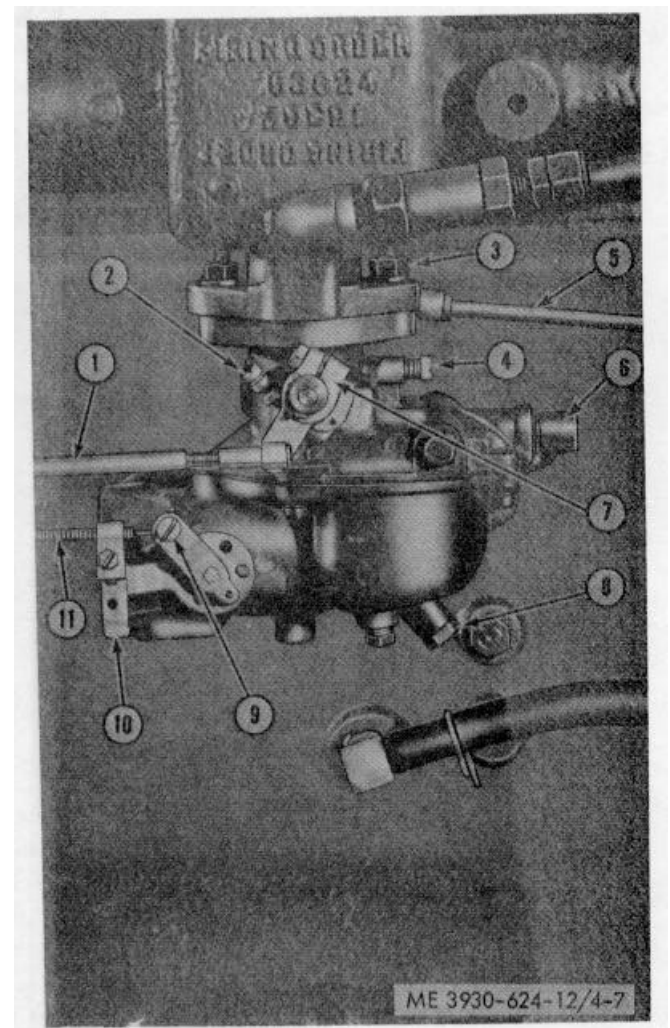

Figure 4-7. Carburetor adjustment.

(3) *Idle fuel adjustment.*

(a) Turn the idle adjusting jet (4) clockwise to obtain a lean mixture or turn counterclockwise to obtain a rich mixture.

(b) Adjust the idle screw until the engine runs smoothly.

*b. Removal.*

(1) Lift the operator's seat, and remove the side panel from the left side of the truck.

(2) Remove the air cleaner and air cleaner hose from carburetor (para 4-25).

(3) Disconnect the fuel inlet line (6).

(4) Remove the accelerator rod (1) and governor control rod (5). Note the position of the throttle lever and governor lever before removing the control rods.

**Note. Do not change the lengths' of rods.**

(5) Disconnect the choke control cable (11).

(6) Remove the two nuts and lockwashers (3) attaching the carburetor to the intake manifold, and remove the carburetor.

*c. Installation.*

(1) Install a new gasket over the studs in the carburetor mounting flange.

(2) Install the carburetor on the intake manifold and secure with two nuts and lockwashers (3).

(3) Position the choke control cable (11) in the choke bracket (10) and install the choke in the swivel connection (9).

(4) Install the governor control rod (5) on the governor throttle lever (7).

(5) Install the accelerator rod (1). If the rod length has been altered, adjust the ball joint so the accelerator pedal will fully open and close the throttle plate.

(6) Connect the fuel inlet line (6) and install the air cleaner by reversing the removal procedure.

(7) Start engine and run until normal operating temperature is reached. Refer to step a for adjustment.

(8) Install any other parts which were removed for carburetor repairs.

#### 4-20. Fuel Pump

*a. Testing.*

(1) Disconnect the fuel outlet line at the fuel pump. Install a 0 to 10 psi pressure gage to the outlet port of the fuel pump. Refer to figure 4-8.

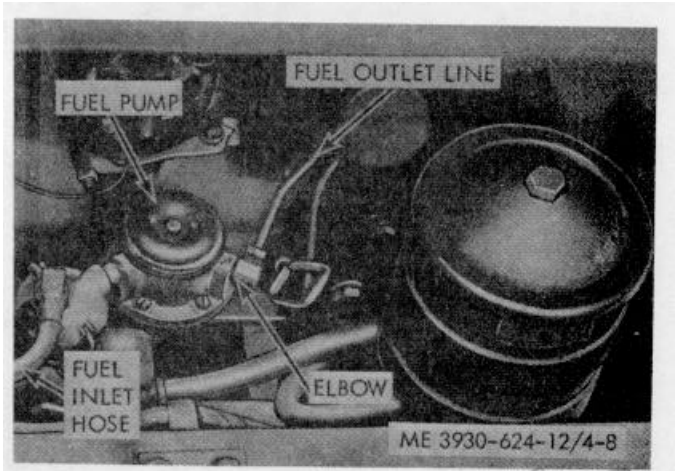

Figure 4-8. Fuel pump.

(2) Run the engine at 1800 rpm on the fuel remaining in the carburetor.

(3) Note the pressure on the pressure gage. The pressure should be between 2 1/2 and 3 3/4 psi.

(4) If the pressure does not fall within these limits, replace the pump.

*b. Inspection.*

(1) Inspect the copper fuel line for restrictions. Blow out the compressed air or replace if damaged.

(2) Inspect the flexible line for breaks or a frayed condition. Replace if necessary.

*c. Removal.*

(1) Close the shut-off valve at the bottom of the fuel tank (fig. 4-9).

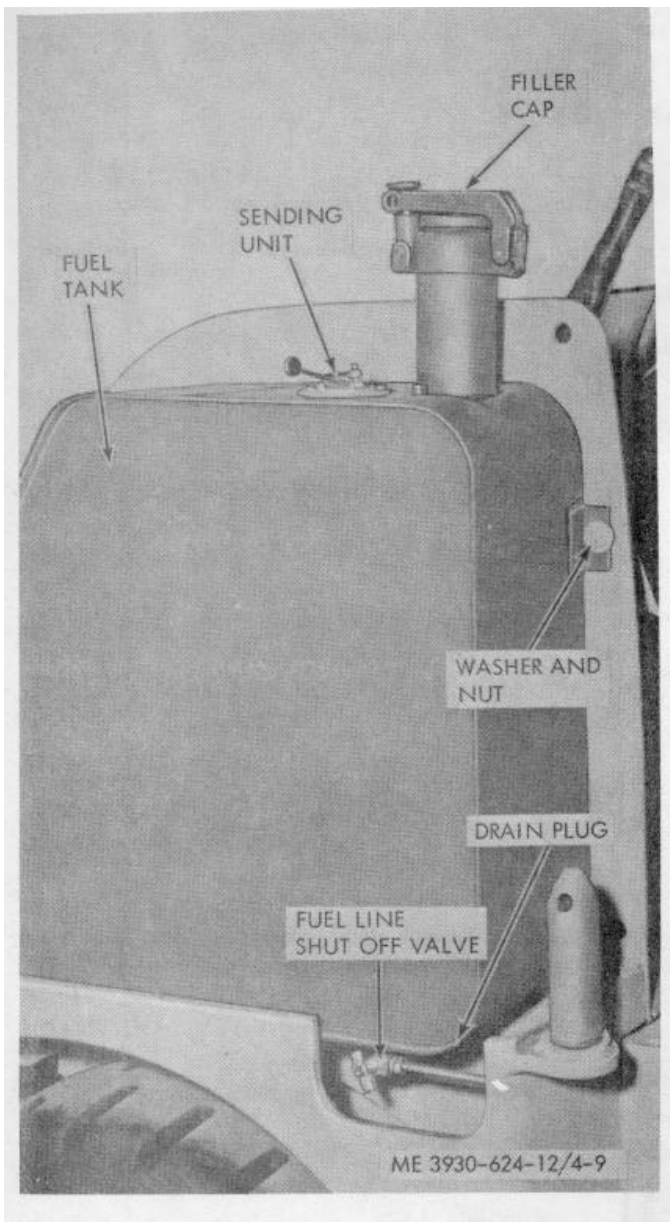

Figure 4-9. Fuel tank.

(2) Lift the operator's seat and remove the side panel from right side of the truck.

(3) Disconnect the fuel outlet line and the fuel inlet hose coming from the fuel tank. Drain hoses into a container of suitable size.

(4) Remove the two pump mounting capscrews and lockwashers and lift the pump from the engine.

(5) Remove and discard gasket; clean surrounding surfaces.

*d. Installation.* Installation of fuel pump is the reverse of the removal procedure. Make certain all line connections are tight. After the fuel shut-off valve is opened, check all connections for leaks.

#### 4-21. Fuel Tank

*a. General.* At periodic intervals of 1000 hours, remove the filler assembly from top of tank and clean the strainer. Remove the drain plug (fig 4-9) from the bottom of the fuel tank and allow sediment and water to drain from the tank.

*b. Removal.*

(1) Remove the three capscrews and lockwashers from the outer edge of the mounting plate and lift the cowl away from the plate.

(2) Disconnect the wire from the terminal of the sending unit in top of the tank as illustrated in figure 4-9.

(3) Close shut-off valve at the bottom of the tank and remove the fuel outlet line from the valve nuts which mount the tank.

(5) Lift tank away from the frame being careful not to damage the tank or shut-off valve.

*c. Installation.* Installation of fuel tank is a direct reversal of the removal procedure.

#### 4-22. Governor Adjustment

*a.* Time the engine (para 4-36) and adjust the carburetor (para 4-19).

*b.* Stop the engine. Remove the floor board and remove return spring (5, fig. 4-12) from the accelerator rod and hold throttle lever in the wide open position.

*c.* Release tension from governor spring and operate the carburetor governor lever manually to check for binding in the linkage. Remove any binding and adjust the governor spring (fig. 4-10) tension to its original position.



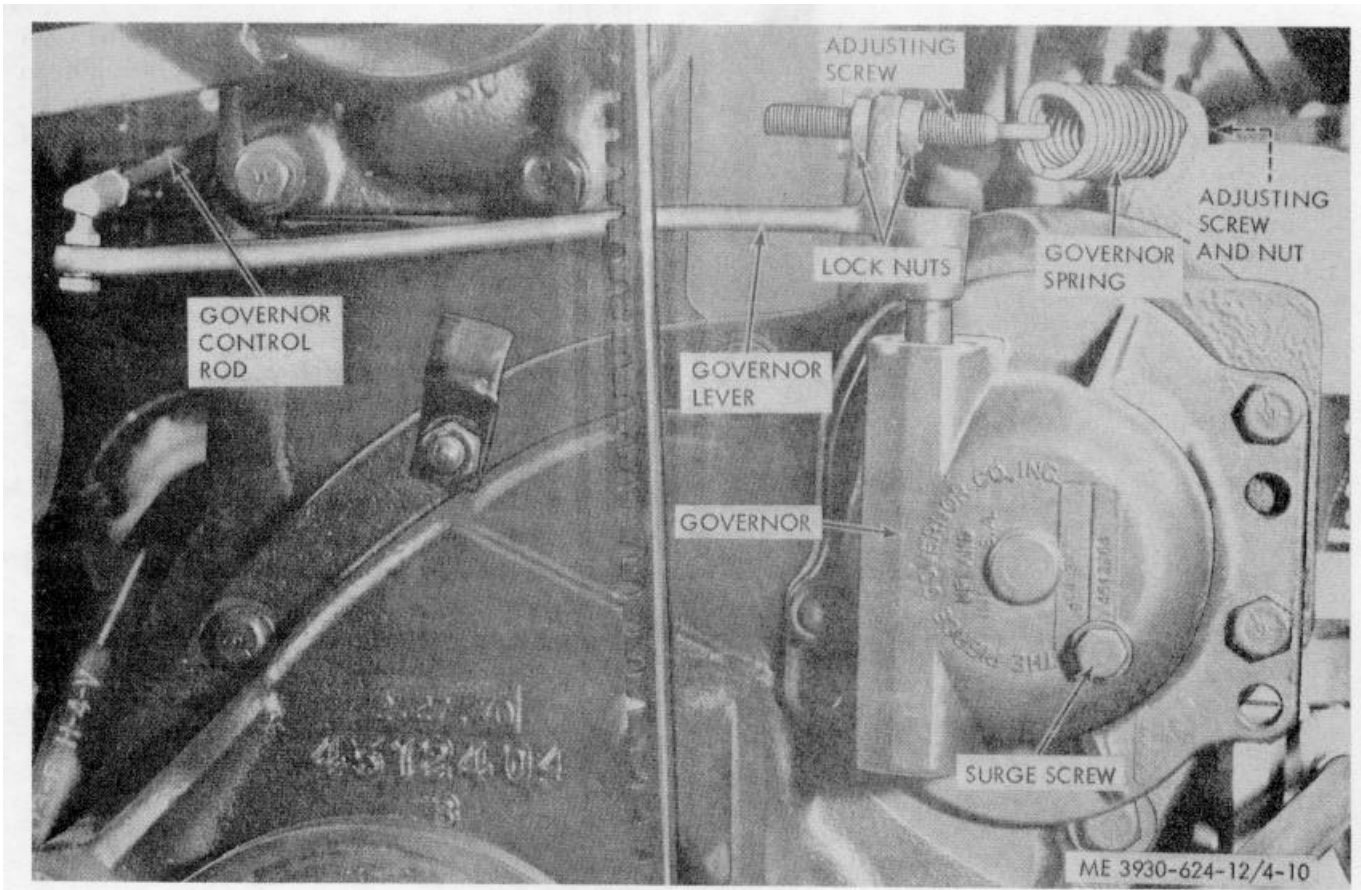

Figure 4-10. Governor adjustment.

d. With tension on the governor spring, adjust the governor control rod length to hold the carburetor lever approximately 1/ 64 inch from the wide open position. Make certain the rod ends are snug and move without friction.

e. Back the surge screw out in the governor housing until only three or four threads are engaged and lock in position.

f. Install an electric tachometer on the engine.

g. Run the engine at full throttle. When the engine has reached normal operating temperature, adjust the governor spring tension nut to obtain an engine speed of 2400 rpm at no load.

h. Load the engine by extending the tilt cylinders until they bottom. This will actuate the relief valve. If the governor surges, move the regulation screw OUT (move the spring away from the throttle level bracket) a few turns at a time until surge is removed. When the

throttle is opened quickly, the governor should surge once or twice and then level off.

**Caution: Engine rpm must be rechecked after making adjustment. Do not turn the surge screw in far enough to increase the no load engine speed.**

#### 4-23. Fuel Filter

a. *Removal.* (fig. 4-11).

(1) Loosen the capnut.

(2) Swing the clamp wire to one side and remove the bowl.

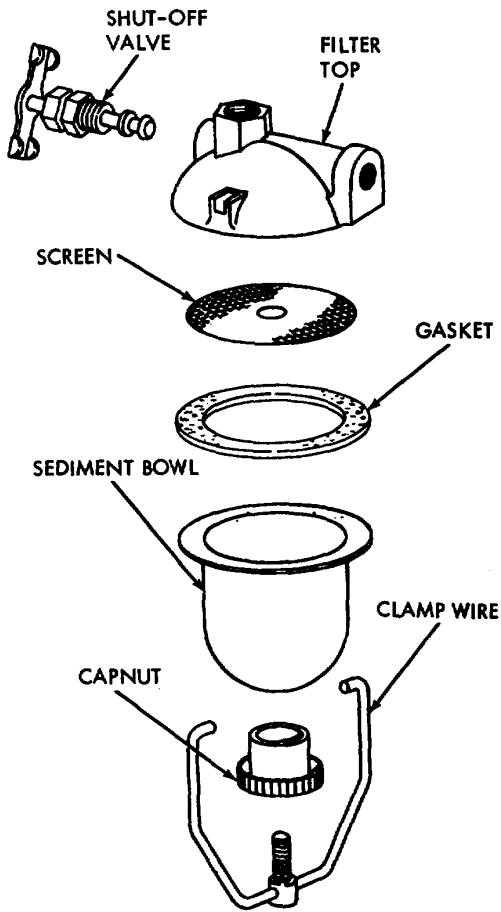

ME 3930-624-12/4-11

Figure 4-11. Fuel filter.

b. *Service.* Thoroughly clean the bowl and screen. If there is excessive dirt on the screen or in the bowl, check the fuel tank and source of supply.

c. *Installation.* Installation is a direct reversal of the removal procedure.

#### 4-24. Accelerator Controls (fig. 4-12)

##### a. *Maintenance and Adjustment.*

(1) Inspect the linkage for secure mounting, presence of pins, spring tension, and proper action.

(2) Periodically lubricate the moving parts of the linkage, except for shaft mounting blocks.

(3) Use the following procedure to adjust the rod length. Refer to figure 4-12.

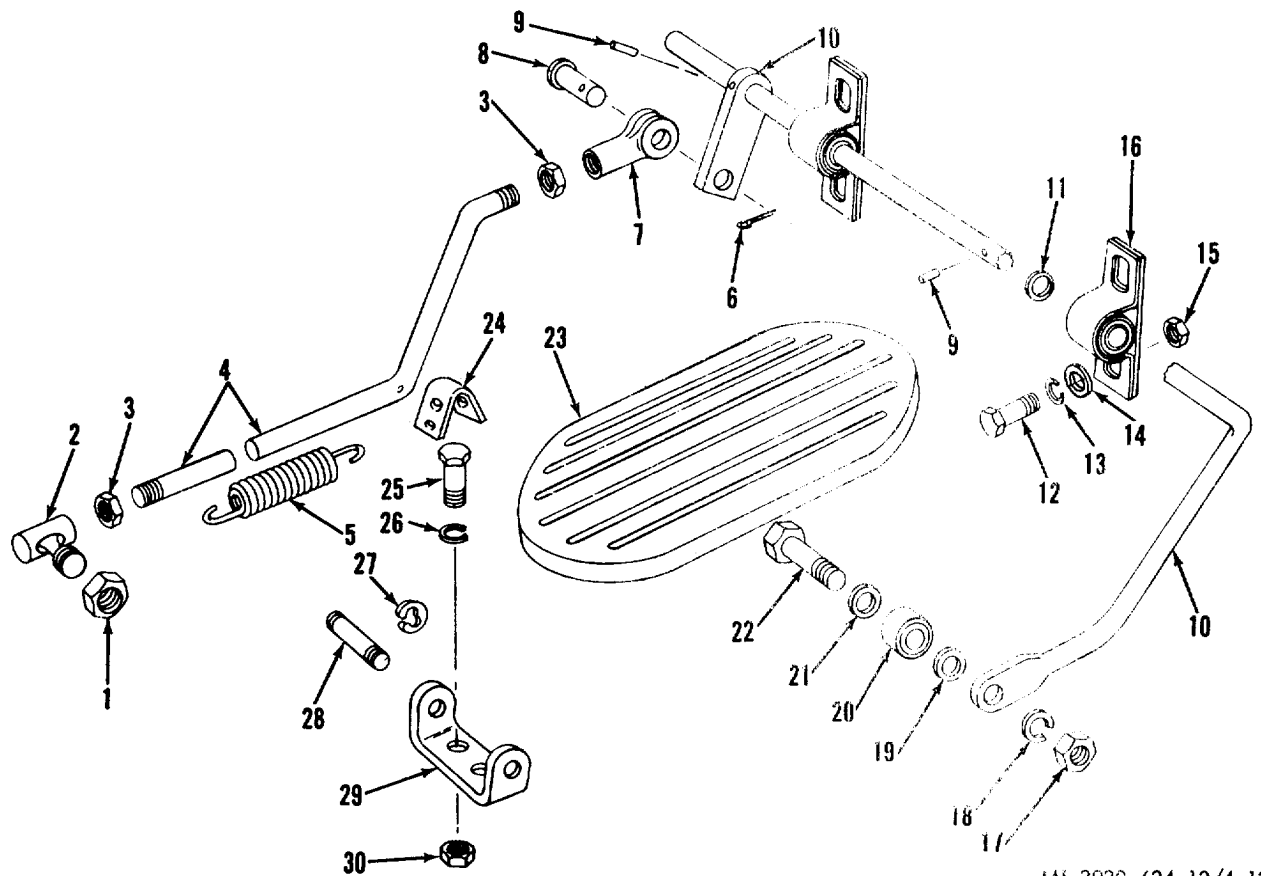

ME 3930-624-12/4-12

- 1. Nut
- 2. Ball joint
- 3. Jam nut
- 4. Rod
- 5. Spring
- 6. Cotter pin
- 7. Clevis
- 8. Pin
- 9. Pin
- 10. Lever and shaft
- 11. Washer
- 12. Bolt
- 13. Lockwasher
- 14. Washer
- 15. Nut

- 16. Mounting block
- 17. Nut
- 18. Lockwasher
- 19. Spacer
- 20. Bearing
- 21. Spacer
- 22. Bolt
- 23. Pedal
- 24. Spring clip
- 25. Bolt
- 26. Lockwasher
- 27. "C" Clip
- 28. Pin
- 29. Bracket
- 30. Nut

Figure 4-12. Accelerator controls.

(a) Remove the ball joint (2) from the carburetor control lever.

(b) Loosen the jam nut (3).

(c) Turn the ball joint so that the throttle closes when the pedal is released.

(d) ensure that full pedal travel opens the throttle fully, adjust the adjusting screw beneath the accelerator pedal (items 9 and 10, fig. 4-65).

**b. Pedal Removal.**

(1) Remove the "E" clip (27, fig. 4-12) from the pedal hinge pin (28).

(2) Slide the pin (28) out of the pedal (23) and bracket (29). Remove the pedal (23).

**c. Shaft Roller Removal.**

(1) Remove the nut (17) and lockwasher (18) from the bearing.

(2) Remove the bolt (22), bearing (20), and two spacers (19) & (21).

**d. Accelerator Shaft Removal.**

(1) Remove the bolt (12) and lockwashers (13), washer (14), and nuts (15) which attach the shaft mounting blocks to the front panel.

(2) Remove the assembly from the truck.

(3) Remove the pin (9) from the accelerator lever and shaft (10).

(4) Slide the lever and mounting blocks off the shaft.

**e. Accelerator Rod Removal.**

(1) Remove the accelerator rod return spring (5) from the spring clip (24).

(2) Remove the nuts and lockwashers from the ball joints at the accelerator lever and throttle lever, and remove the rod (4).

(3) Ball joints can be removed from the accelerator rod by loosening the jam nuts (3) and unscrewing ball joints (2). The spring clip (24) may also be removed at this time.

## Section IX. MAINTENANCE OF THE AIR INDUCTION AND EXHAUST SYSTEM

### 4-25. Air Cleaner

**a. General.** The oil bath air cleaner is mounted on the left side of the engine and is connected to the carburetor by a flexible rubber hose. It prevents dust and foreign matter from entering the carburetor and the engine.

**b. Service.** Service the air cleaner as directed in paragraph 3-2.

**c. Removal and Disassembly.** Remove the air cleaner. Disassemble the air cleaner to the extent necessary for cleaning. Refer to figure 4-13.

Key to fig. 4-13.

1. Wingnut
2. Seal
3. Air cleaner-top and body
4. Gaskets
5. Hose clamp
6. Hose

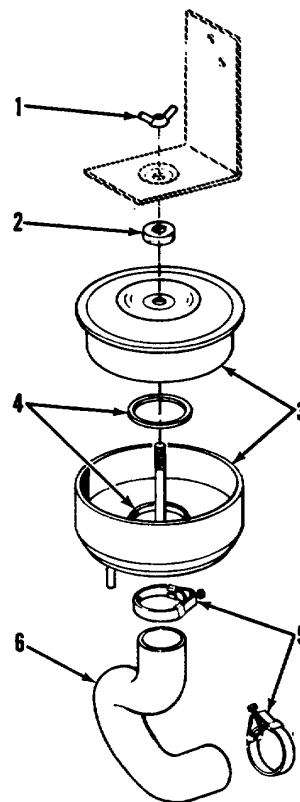

ME 3930-624-12/4-13

Figure 4-13. Air cleaner and connections.

*d. Cleaning and Inspection.*

(1) Clean the air cleaner body with a cloth dampened with a cleaning solvent. Blow out dust and dirt with a stream of clean, dry, low pressure (25 psi maximum) compressed air. Direct the air stream in a direction that is the reverse of the normal air flow.

(2) Blow out the air cleaner-to-carburetor air hose with compressed air. If necessary, flush it out with a solvent that is not injurious to the rubber.

(3) Clean all remaining parts with a cleaning solvent; dry thoroughly.

(4) Inspect the air cleaner body for cracks, severe dents, distortion, and other damage. Replace the air cleaner if damaged.

(5) Inspect all other parts for cracks, distortion, damaged threads or other damage; replace damaged parts.

*e. Reassembly and Installation.* Reassemble and install the air cleaner in the reverse order of removal.

#### 4-26. Exhaust Muffler and Piping

*a. General.* The exhaust system conducts the exhaust gases from the engine through an exhaust pipe, muffler, tailpipe and then discharges them into the atmosphere. The muffler dampens the exhaust noises by directing the gas flow through a series of baffles.

*b. Removal and Disassembly. (fig. 4-14.)*

(1) Remove the driver's seat and left hand engine side panel.

(2) Remove the radiator grille by removing the capscrews, lockwashers, and washers securing the grille to the truck frame. (para. 4-67.)

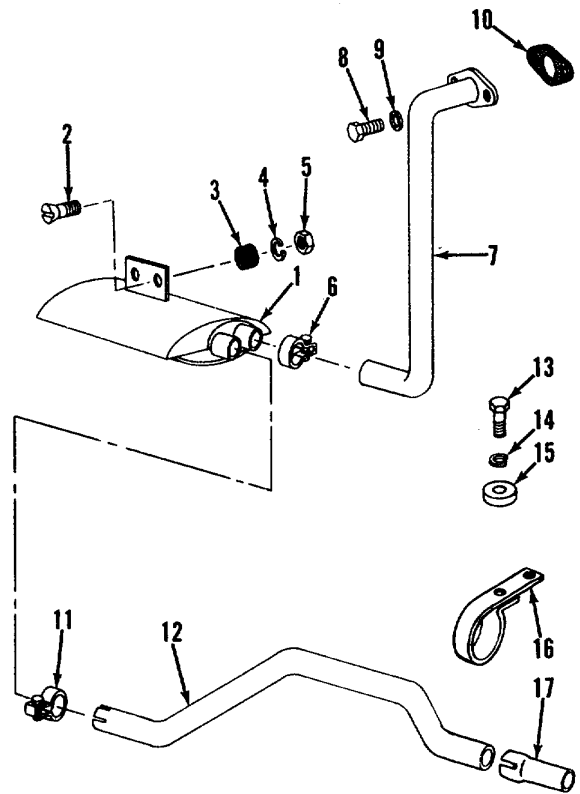

ME 3930-624-12/4-14

- |                 |                      |
|-----------------|----------------------|
| 1. Muffler      | 10. Gasket           |
| 2. Screw        | 11. Clamp            |
| 3. Grommet      | 12. Tailpipe         |
| 4. Lockwasher   | 13. Bolt             |
| 5. Nut          | 14. Washer           |
| 6. Clamp        | 15. Spacer           |
| 7. Exhaust pipe | 16. Clamp            |
| 8. Bolt         | 17. Sleeve extension |
| 9. Washer       |                      |

Figure 4-14. Exhaust system.

(3) Raise left side of the truck to reach the muffler which is located underneath the floor plate.

(4) To remove the exhaust pipe (7), loosen the clamp (6) securing the pipe to the muffler (1) and remove the two bolts (8) and washers (9) mounting the exhaust pipe to the manifold.

(5) To remove tailpipe (12), loosen clamp (11) securing the pipe to the muffler and remove the clamp (16) securing the tailpipe to the truck frame.

(6) To remove muffler, disconnect exhaust pipe (7) and tailpipe (12) and remove the two screws (2), nuts (5) and lockwashers (4) securing it to the truck frame. Remove the two grommets (3) from muffler mounting bracket.

*c. Inspection.* Inspect all the components of the exhaust system for corrosion, leaks, or damage. Replace defective parts.

*d. Installation.*

(1) Install the grommets (3) in muffler mounting bracket and secure muffler (1) to truck frame with two screws (2), lock washers (4) and nuts (5).

(2) Secure exhaust pipe (7) to muffler with clamp (6), and using new gasket (10), secure to manifold with two bolts (8) and washers (9).

(3) Secure tailpipe (12) to muffler (1) with the clamps (11 & 16).

(4) Slide sleeve extension (17) through counterweight opening onto open-end of tailpipe. Push sleeve all the way onto tailpipe, to secure it in position.

(5) Inspect all connections for exhaust leaks.

(6) Install left hand engine side panel, driver's seat and secure radiator grille to truck frame with capscrews, lockwashers and washers.

## Section X. MAINTENANCE OF THE COOLING SYSTEM

### 4-27. General

The cooling system cools the engine, torque converter, and transmission. The system consists of the radiator, thermostat, fan, water pump, and hoses. Engine coolant is circulated by the water pump through the engine to the radiator where it is cooled. The radiator is cooled by the flow of air circulated by the fan. When the engine coolant is below operating temperature, the thermostat closes, preventing the circulation of coolant through the radiator until the coolant reaches the proper temperature. Torque converter and transmission oil is transferred through hoses to the lower part of the radiator where it is cooled.

### 4-28. Radiator

#### *a. Cleaning.*

(1) Clean foreign matter from the cooling fins by forcing compressed air through the radiator from the counterweight toward the engine.

(2) Flush the cooling system with a chemical cleaner in accordance with current directives. After flushing, fill the cooling system with anti-freeze solution (table 2-1) containing a rust inhibitor or water and rust inhibitor in accordance with current directives.

(3) If the cooling system is badly clogged with rust and scale, reverse flush the radiator and engine as follows:

(a) Drain the cooling system.

(b) Loosen the clamps and disconnect the upper and lower radiator hoses.

(c) Connect the flushing gun to the lower hose as shown in figure 4-15. Fill the radiator with water. Shut off the water supply and blow the water out of the radiator with air. Apply air pressure gradually to prevent damage to the radiator. Repeat this process until the flushing stream runs clear. Disconnect the flushing gun.

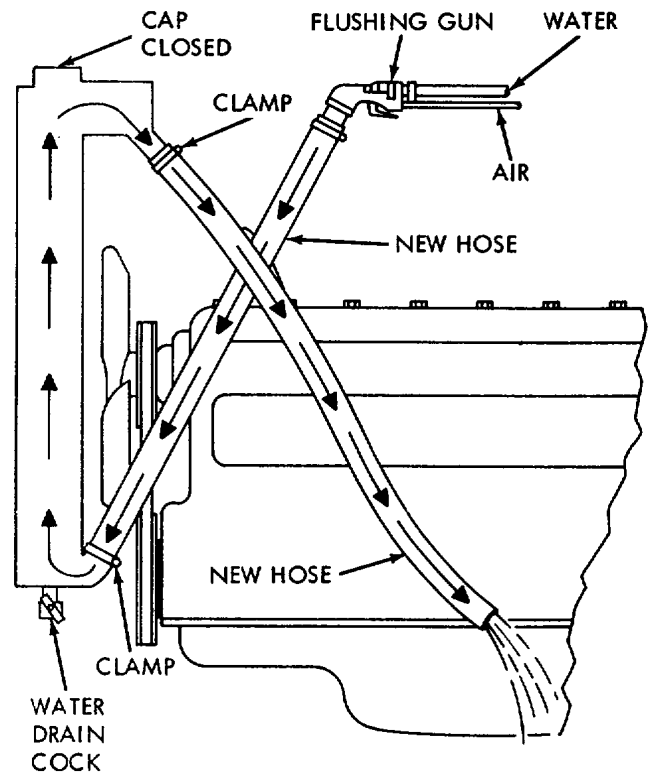

ME 3930-624-12/4-15

Figure 4-15. Reverse flushing the radiator.

(d) Remove the bypass hose from the elbow on the thermostat housing and water pump. Install a plug in the elbow on the thermostat housing. Refer to figure 4-17.

(e) Remove the outlet pipe from the thermostat housing and remove the thermostat. Reinstall the outlet pipe.

(f) Connect the flushing gun to the upper hose on the thermostat housing as shown in figure 4-16. Completely fill the engine water jacket with water. Hold a hand over the water pump outlet to be sure the water jacket is completely full. Shut off the water supply. Blow the water out of the water jacket with air. Repeat this procedure until the flushing stream runs clean. Disconnect the flushing gun.

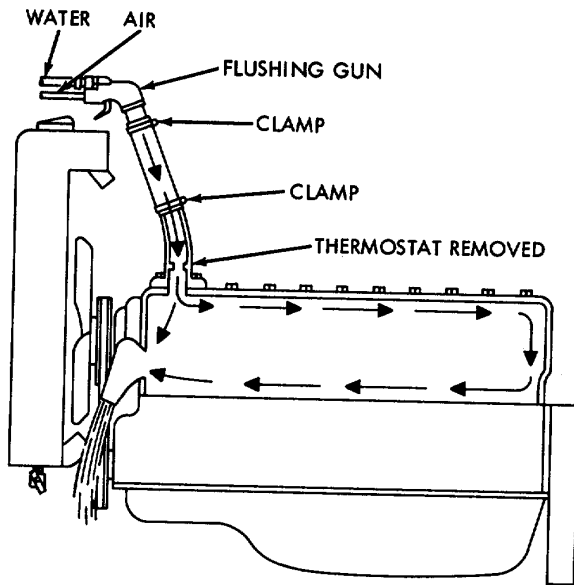

ME 3930-624.12/4-16

Figure 4-16. Reverse flushing of engine block.

**b. Removal.**

(1) Raise driver's seat and remove side panels.

(2) Remove the radiator grille by removing nuts and lockwashers from studs which attach grille to truck frame. (para 4-67.)

(3) Drain the radiator by opening the drain cock (fig. 4-15).

(4) Loosen hose clamps which secure coolant inlet and outlet hoses to the radiator. Disconnect transmission oil cooler lines from the fittings in bottom of the tank of the radiator.

(5) Remove the four capscrews and lockwashers which attach radiator to truck frame from the inside of engine compartment.

**CAUTION: Do not lose any spacers that may be present between radiator and frame mounting.**

(6) Slide bottom of radiator out first through

the center of counterweight. After top of radiator has cleared inside top of counterweight, it can be easily lifted out.

**c. Installation.**

(1) Install radiator by a direct reversal of removal procedure.

**Note.** If spacers were present between radiator mounting flange and frame, be sure to replace in original locations. If none were present, but there is space between radiator mounting flange and frame, use spacers as necessary to prevent strain on radiator when mounting bolts are tightened.

(2) After radiator is installed, measure distance between leading edge of fan blades and radiator core. This dimension should be approximately 7/8". Also, make certain cooling fan is centered in radiator shroud.

(3) Close radiator drain cock, fill system and check for leaks.

(4) Install rear grille and side panels.

**4-29. Thermostat**

**a. Removal.**

(1) Raise the driver's seat and remove the side panels.

(2) Drain the radiator.

(3) Remove two capscrews securing the outlet pipe from the thermostat housing. Remove thermostat from housing. Refer to figure 4-17.

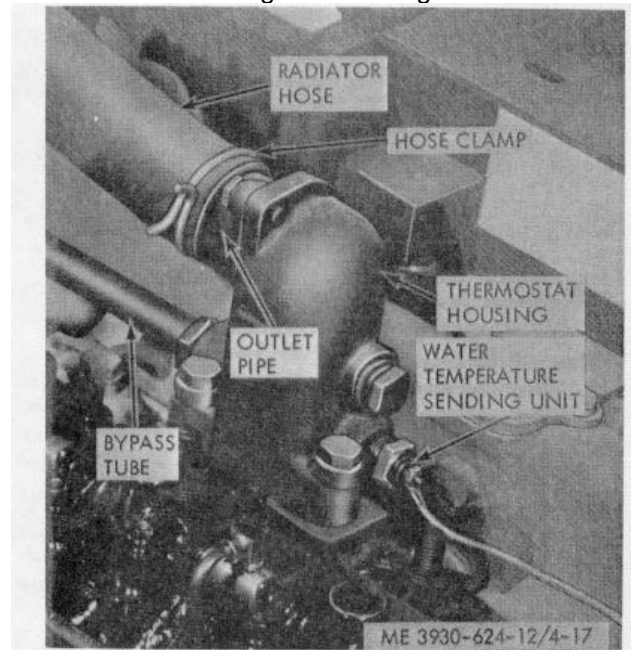

ME 3930-624-12/4-17

Figure 4-17. Thermostat location.

**b. Inspection.**

(1) Inspect the thermostat and thermostat housing for cracks, distortion, scale, dirt deposits, or other physical damage.

(2) Replace the thermostat if defective.

c. *Installation.*

(1) Coat the gasket surface of the housing with sealer.

(2) Install the thermostat in its proper position.

(3) Place the gasket on the housing and install the outlet pipe securely with capscrews.

(4) Close drain cock and fill cooling system as specified in table 2-1.

#### 4-30. Water Pump

a. *Removal and Disassembly.*

(1) Raise the driver's seat and remove the side panels.

(2) Drain the radiator.

(3) Remove the radiator (para 4-28).

(4) Loosen the hose clamp and remove the coolant inlet hose from the pump (fig. 4-18).

(5) Loosen the nut at each end of the coolant bypass tube and remove the tube, refer to figure 4-17.

(6) Loosen the alternator adjusting screws and move the alternator towards the cylinder block, freeing the fan belt (fig. 4-19).

(7) Loosen and remove the four capscrews and lockwashers securing the fan and pulley to the water pump hub. Remove the fan blade and pulley (fig. 4-18).

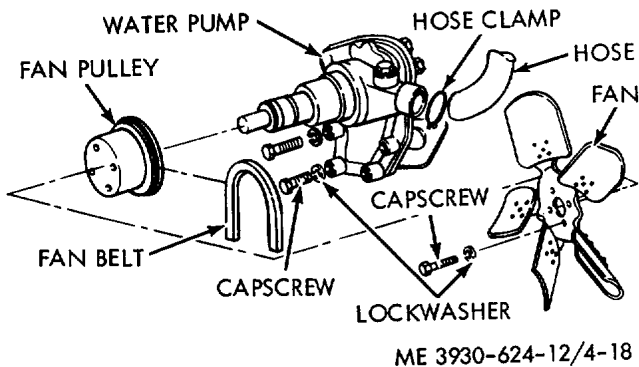

Figure 4-18. Water pump and fan blade.

(8) Remove the four capscrews and lockwashers securing the water pump to the cylinder block. Remove the pump.

b. *Cleaning and Inspection.*

(1) Discard gasket. Clean the pump with a cleaning solvent; dry thoroughly.

(2) Inspect the water pump for cracks, signs of leaking, and other damage. Turn the pump shaft. It must rotate freely, without catching or binding. Replace if damaged.

(3) Inspect the fan blade for cracks, distortion, loose fan elements, and other damage; replace if damaged.

c. *Installation.*

(1) Coat new gasket with sealing compound, place on pump body. Place pump in position and attach to cylinder block. Alternator adjusting brace is secured by upper left capscrew. At this time do not tighten alternator adjusting brace capscrew; but, torque three remaining capscrews to 18 to 21 ft-lbs. Tighten brace capscrew after making belt adjustment (para 4-31).

(2) Install coolant bypass tube between pump and outlet manifold. Make certain connection nuts are tight to prevent leakage.

(3) Install pump inlet hose on pump.

(4) Place drive pulley in position over pulley hub. Position fan belt over pulley. Install cooling fan by positioning pulley and fan on hub. Then install capscrews and lockwashers and tighten to 11 to 13 ft-lbs.

(5) Make certain fan belt is correctly positioned on fan, alternator and crankshaft pulleys. Adjust fan belt tension (para 4-31).

(6) Install radiator by a direct reversal of removal procedure.

#### 4-31. Fan Belt

a. *Adjustment.* The fan belt must be tightened so that it can be deflected  $\frac{1}{2}$ " at a point midway between the water pump and the alternator. If necessary, adjust the belt as shown in figure 4-19.

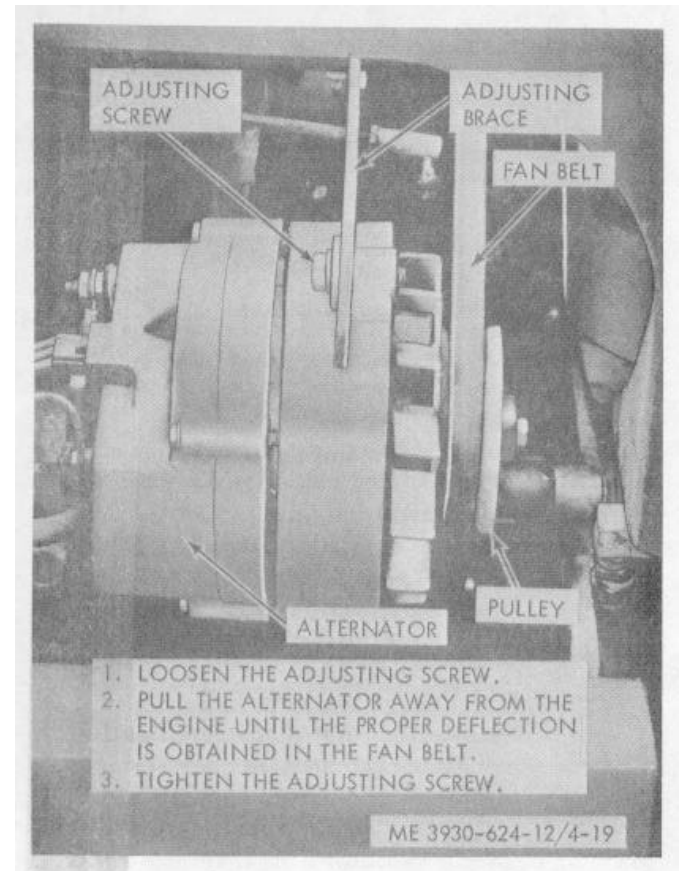

Figure 4-19. Fan belt adjustment.



*b. Replacement.*

(1) Remove the rear grille from the counterweight.

(2) Raise the operator's seat and remove the side panels.

(3) Remove split flange on the suction tube on the hydraulic pump; remove the pump as shown in figure 4-20.

(4) Remove the four capscrews and washers securing the pump to the engine block. Slide the pump away from the engine block to provide enough clearance to install the fan belt.

(5) Loosen the alternator to relieve the tension on the fan belt. Slide the belt from the crankshaft pulley.

(6) Slide the belt off the alternator pulley, then off fan pulley and over the fan.

**Caution:** Care should be not taken. To bend the radiator fins.

(7) Install a new belt over the fan and around the fan pulley, alternator pulley and crankshaft pulley.

(8) Adjust the fan belt (para 4-31).

(9) Install the hydraulic pump by direct reversal of the removal procedure. Install the rear grille.

(10) Install the side panels and the lower seat.

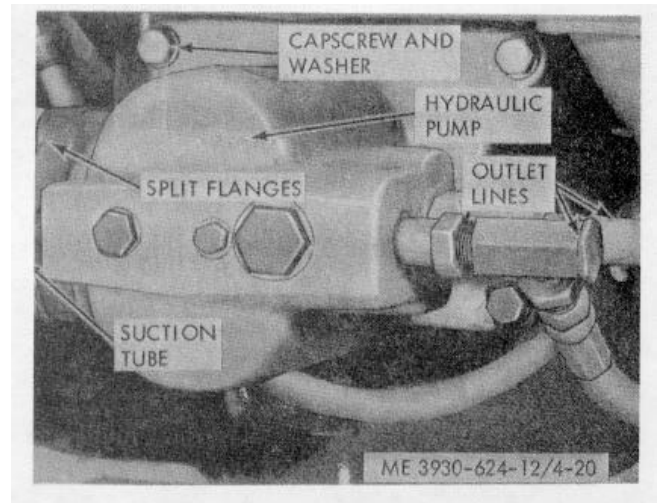

Figure 4-20. Hydraulic pump removal.

## Section XI. MAINTENANCE OF THE ELECTRICAL SYSTEM

### 4-32. General

The electrical wiring diagram for the truck is shown in figure 1-3. The electrical system includes battery distributor, alternator, ignition coil, spark plugs, starter motor, solenoid, current and voltage regulator, wiring, and accessories. Electrical gages and horn are protected by fuses in the circuit. Fuses are located on the underside of the instrument panel. The instrument panel wiring terminates in a multiple male connector. The engine, accessories, and chassis wiring terminates in a multiple female connector to provide a quick disconnect for ease of service.

### 4-33. Alternator

*a. Testing the Alternator.*

(1) Disconnect the four terminal connector from the regulator.

(2) Disconnect the two-terminal connector from the alternator F and R terminals.

(3) Connect a jumper wire from the BAT terminal to the F terminal on the alternator.

(4) Connect a voltmeter from the alternator BAT terminal to the GRD terminal.

(5) Start the engine and turn on the lights. Run the engine at 1500 RPM or above and note whether voltage exceeds 12.5 volts. If voltage exceeds 12.5 in a few minutes, the alternator output is operating normally. Stop the engine, turn off lights and connect wiring.

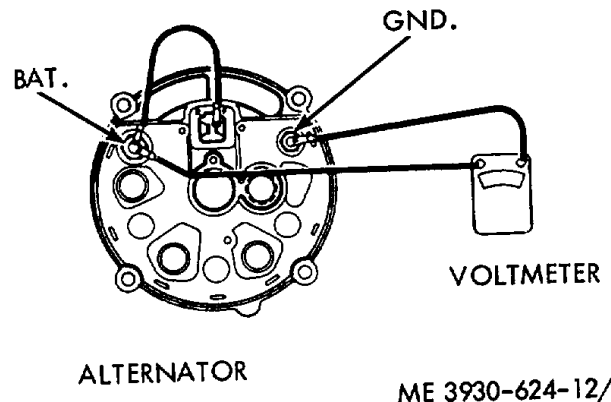

Figure 4-21. Checking alternator output.

*b. Removal.*

**Warning:** Always disconnect the battery cable from the negative battery post before making electrical repairs on the truck.

(1) Tag the electrical leads to alternator; disconnect the leads.

(2) Loosen the fan belt and remove the alternator.

*c. Installation.*

(1) Install the alternator by reversing the removal procedure.

**Caution: Do not attempt to polarize the alternator.**

- (2) Connect all leads and remove the tags.
- (3) Adjust fan belt tension (para 4-31).

Table 4-3. Alternator Output Specifications

Rotation viewing D.E.	Cold output at specified voltage						Rated hot output (Amps.)
	Grd.	Spec. volts	Amps.	Approx. R.P.M.	Amps.	Approx. R. P. M.	
CW	Neg.	14.0	12	1100	42	6500	42

**4-34. Voltage Regulator**

a. *Testing an Adjustment.* The regulator is illustrated on figure 4-22.

(1) Operate the engine at approximately 1500 rpm for 15 minutes with the headlights on. A thermometer should be placed 1/4" from the regulator cover.

(2) With the engine running, record the voltage reading -with a voltmeter connected between terminal No. 3 or No. 4 and ground as shown in figure 4-23.



Figure 4-22. Voltage regulator.

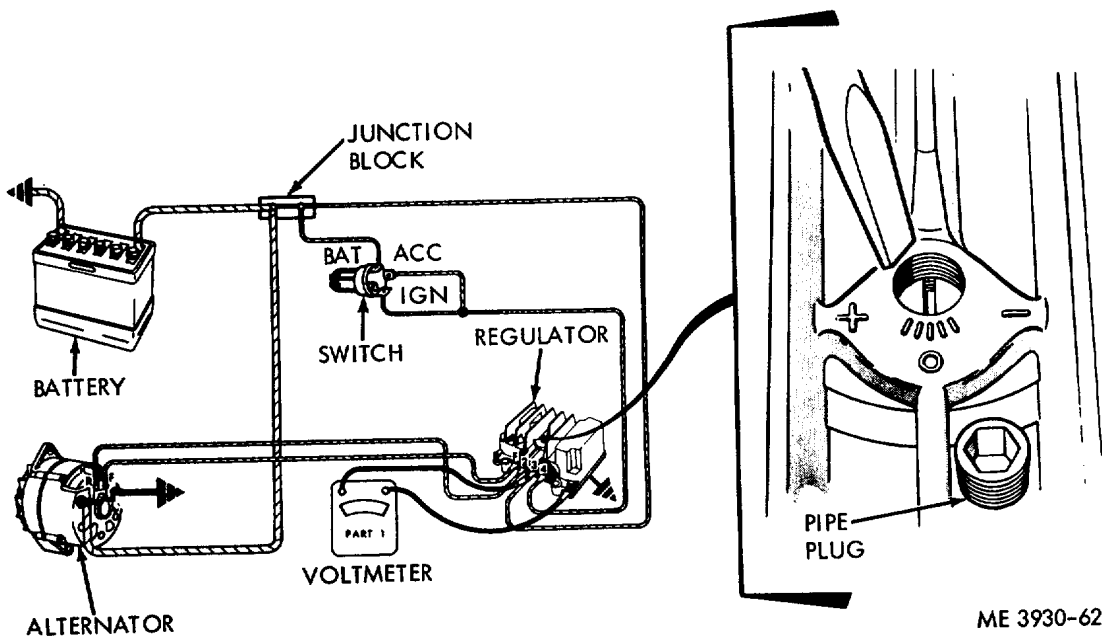

ME 3930-624-12/4-23

Figure 4-23. Checking voltage regulator setting.

**Note.** Either terminal is satisfactory for this check provided a lead is connected to it.

(3) Compare the voltage obtained in step (2) with voltage table 4-4. Ambient temperature is the temperature of the air measured 1/4 inch from the regulator cover.

(4) If the actual voltage is not within the

specified range, remove the pipe plug (fig. 4-23) from regulator cover and note the position of the plastic screw slot beneath the plug. The slot will be lined up with one of the divisions or lines cast in the regulator cover. Each division represents a voltage differential of 0.3 volt. Add or subtract 0.3 volt for each division from the zero mark to the specified voltage limits in table 4-4.

Table 4-4. Voltage Table

Ambient temperature (Deg F)	65°	85°	105°	125°	145°
Normal Voltage Setting (Volts)	14.1 to 14.9	13.9 to 14.7	13.7 to 14.5	13.5 to 14.3	13.4 to 14.2

(5) If the voltmeter reading does not fall within the specified limits outlined in table 4-4, replace the regulator. If the reading does fall within the prescribed limits, but the battery is either overcharged or undercharged, the regulator should be adjusted as outlined in the next step.

(6) Voltage setting adjustment.

(a) the voltage uses too much water at the voltage regulator's present setting, reduce the voltage setting by 0.3 volt, one division on cover, and check for decreased battery water usage over a reasonable period of time. If necessary, repeat this process until the battery remains charged with a minimum use of water.

(b) If the battery is consistently undercharged, (evidenced by the inability to crank the engine) at the regulator's present setting, increase the voltage setting by 0.3 volt and check for improved condition over a reasonable service period. If necessary, repeat this process until the battery remains charged with a minimum use of water.

b. Removal.

(1) Tag and disconnect the leads to the voltage regulator.

(2) Remove three capscrews lockwashers, and nuts; remove the voltage regulator.

c. Installation. Install regulator by direct reversal of removal.

#### 4-35. Starting Motor

##### a. Testing.

(1) Use a battery known to be in good condition and an accurate voltmeter. Connect the positive lead of the voltmeter to the positive terminal of the battery, and the negative lead to the negative terminal of the battery. Record the voltage reading.

(2) Pull the high tension lead from the ignition coil to prevent the engine starting during the starting motor test.

(3) Connect the positive lead of the voltmeter to the ground and the negative lead of the voltmeter to the starter button terminal. Turn the ignition switch on and push the starter button and read the voltmeter.

(4) Compare the voltmeter reading with the previously recorded voltmeter reading. If the voltage drop is less than 4 volts, or if the second reading is less than 8 volts, the starting motor is probably faulty.

##### b. Removal. (fig. 4-24).

(1) Lift the operator's seat and remove the side panels.

(2) Disconnect the negative battery cable from the battery.

(3) Tag and disconnect all electrical leads to the starting motor.

(4) Remove the mounting bolts securing the starting motor to the flywheel housing.

(5) Pull the starting motor out of the flywheel housing until the drive end clears the flywheel housing and tilt the commutator end up to remove the unit from the truck.

##### c. Cleaning and Inspecting.

(1) Clean the exterior of the starting motor with a cloth dampened with a cleaning solvent; dry thoroughly. Take care to prevent the solvent from entering the starting motor.

(2) Inspect the starting motor for cracks, bent or damaged terminals, signs of overheating, damaged pinion teeth, and other damage. Check the armature shaft for free rotation. Replace the starter if damaged.

##### d. Installation.

(1) Install the starting motor using the direct reversal of the removal procedure.

(2) Check the operation of the starting motor. Make sure it cranks the engine as required.

#### 4-36. Ignition Distributor

##### a. Distributor Points, Repair and Replacement.

(1) Remove the distributor cap by loosening the retaining screws and remove the rotor and the dust shield from the distributor housing.

(2) Remove the nut and washer from the inner end of the primary terminal (fig. 4-25).

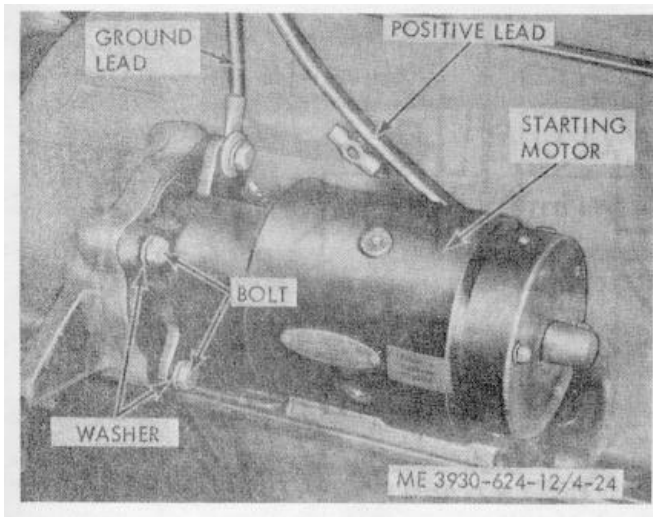

Figure 4-24. Starting motor.

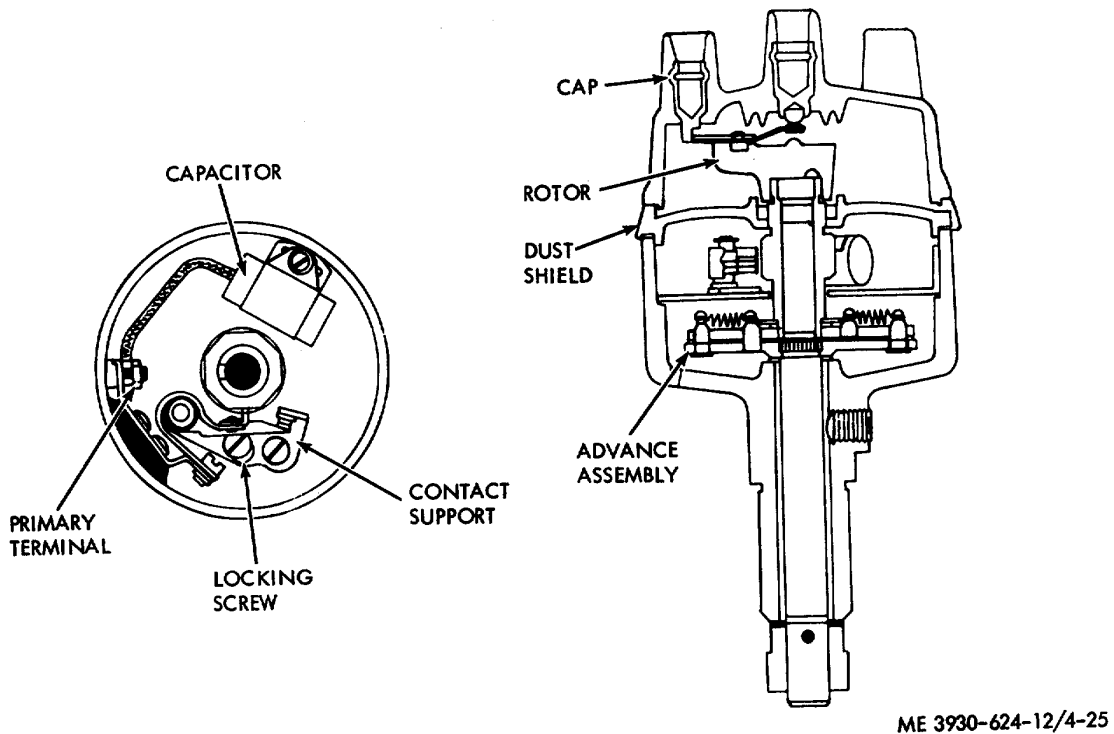

Figure 4-25. Distributor.

(3) Remove the slotted head locking screw attaching the contact support to the distributor breaker plate, and remove the contact points. If the capacitor is to be replaced, remove the screw attaching the capacitor to the breaker plate and remove the capacitor.

(4) Apply a light coat of grease to the distributor cam. Install a new capacitor. Install a new contact support over the pivot post and start the slotted head locking screw attaching contact support to breaker plate, but do not tighten the screw at this time. Install the breaker lever over the pivot post and over the inner end of the primary terminal. Install and tighten the nut on the primary terminal.

(5) Rotate the crankshaft until the breaker lever rubbing block is on a high spot on the cam, thus opening the contact points to their maximum open position. Turn the eccentric adjusting screw to obtain the specified contact point gap of 0.016 in. Lock the points in position by tightening the contact plate locking screw. After tightening contact plate locking screw, recheck point gap. Refer to figures 4-26 and 4-27.

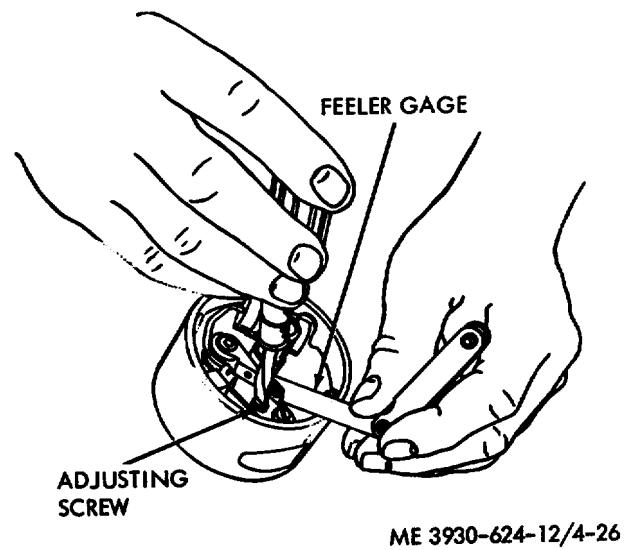

Figure 4-26. Adjusting contact gap.

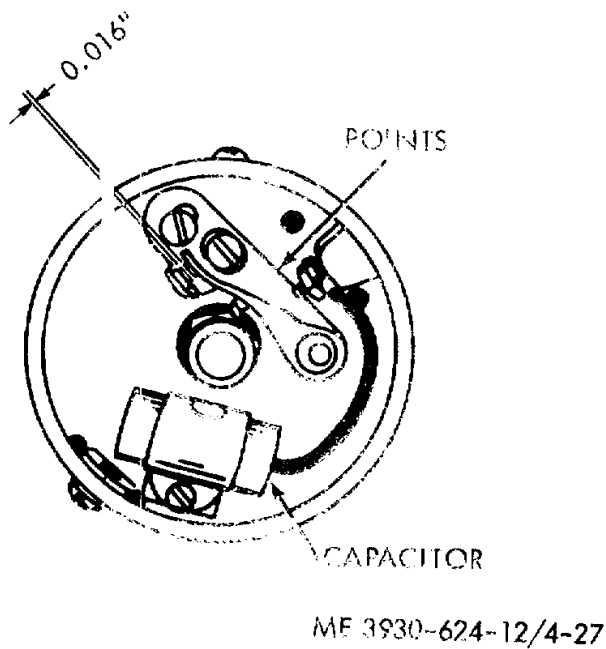

Figure 4-27. Breaker point gap.

(6) Install the dust shield rotor and distributor cap.

*b. Timing Distributor to Engine*

(1) Loosen the screw at the distributor advance arm and set the pointer at 0 (fig.4-28).

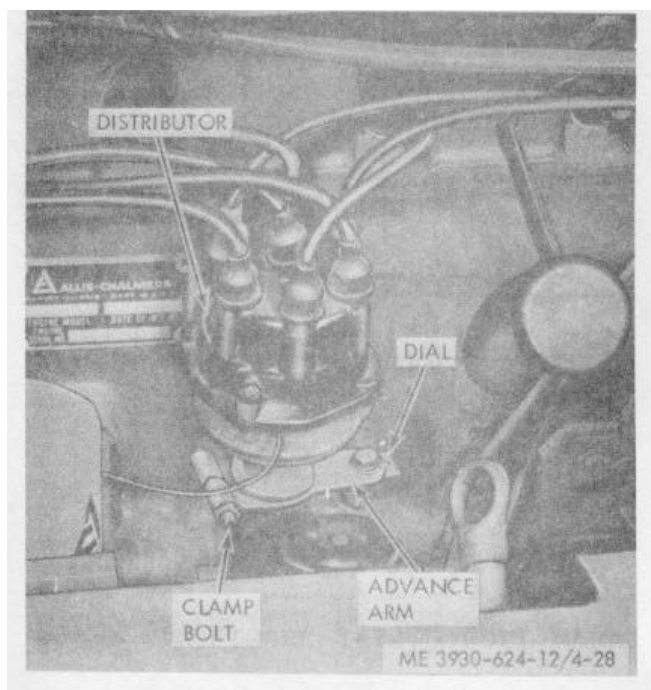

Figure 4-28. Distributor timing adjustment.

(2) Advance the flywheel until the ignition timing line on the flywheel is aligned with the reference line on the flywheel housing. This line is TDC (top dead center). Refer to figure 4-29.

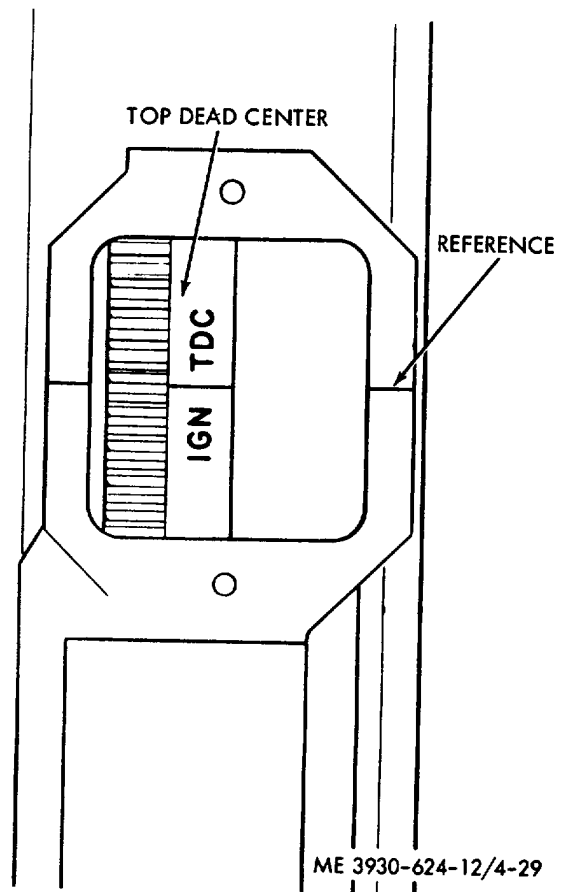
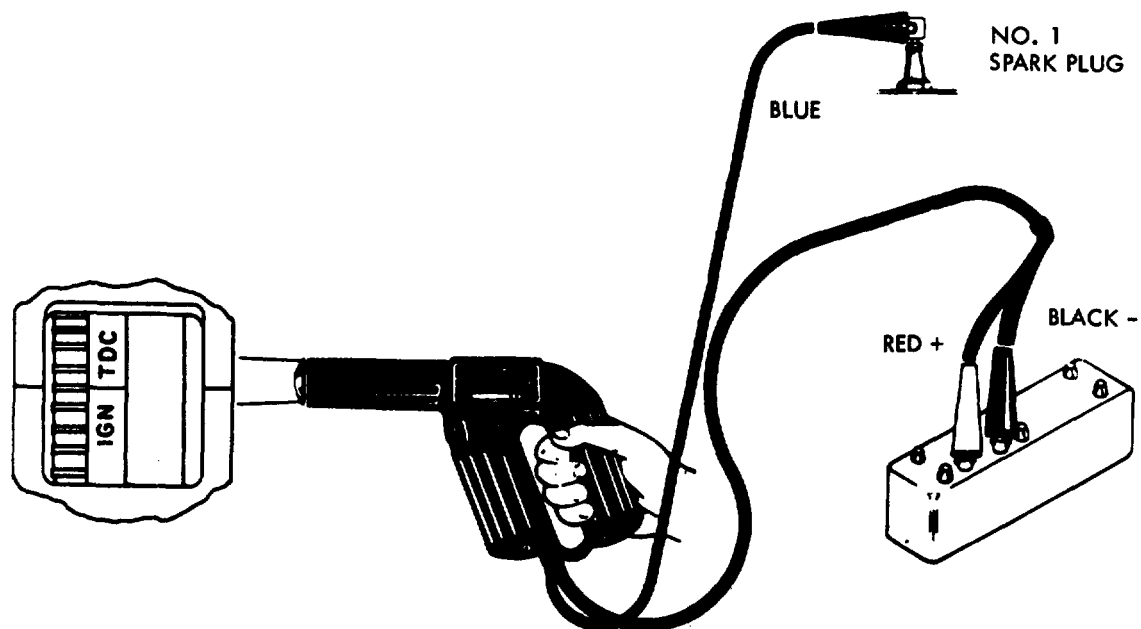

Figure 4-29. Flywheel timing mark.

(3) If necessary, mark the flywheel and housing with white chalk or paint.

(4) Connect a timing light as shown in figure 4-30.



ME 3930-624-12/4-30

Figure 4-30. Timing light connections.

(5) Connect the hot lead of a tachometer to the positive lead on the coil and connect remaining lead to ground.

(6) Start the engine and, using the idle adjusting screw, lower the idle speed until there is no apparent distributor advance or retard (approximately 300 to 350 rpm).

(7) Direct the timing light at the timing hole in the flywheel housing and rotate the distributor to set timing to TDC.

(8) Increase the idle speed to 400 RPM.

(9) With the timing light, again check flywheel timing and note whether timing has advanced. Then tighten the distributor advance screw.

(10) After timing is correctly adjusted, accelerate the engine rapidly a few times and observe

the movement of the flywheel timing mark. If the spark advance is functioning properly, the mark will move counterclockwise on the flywheel during acceleration and drop back as the engine decelerates to idle speed.

*c. Removal and Disassembly.*

(1) Remove spark plug leads from spark plugs and remove ignition coil lead from coil. Remove primary lead from coil.

(2) Remove capscrew and washers from distributor advance arm and lift distributor out of drive housing.

(3) Unfasten cap retainer screws and remove cap, rotor, and dust shield (fig. 4-31).

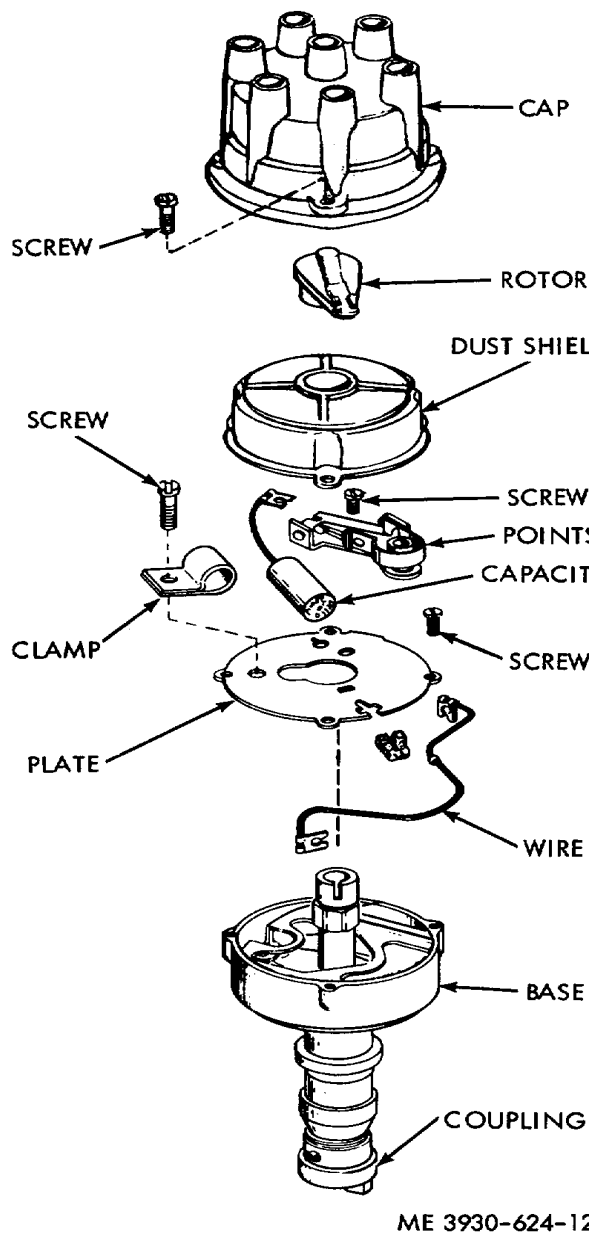

Figure 4-31. Distributor assembly.

(4) Remove contact points and capacitor.

(5) Remove nuts and washers from end of primary terminal and then remove stud and the two insulating blocks.

*d. Inspection of Distributor.*

(1) Clean all parts thoroughly and replace any damaged or worn parts. However, do not clean cap,

dust shield, rotor, capacitor, insulators or housing in any degreasing compound, since this may damage parts.

(2) Check centrifugal advance parts, weights, springs and plate for signs of wear or damage. If damaged, replace the distributor.

(3) Replace contact points if worn or badly pitted.

(4) Check breaker lever rubbing block for excessive wear.

(5) Check capacitor for leakage. If it cannot be tested, replace.

(6) Check distributor cap and rotor for cracks, burning of contacts or carbon streaks. Replace if damaged.

*e. Assembly and Installation of Distributor.*

(1) Install primary lead.

(2) Install capacitor and contact points. Set point gap to 0.016 in.

(3) Saturate felt wick in breaker cam with light engine oil and then install dust shield and rotor.

(4) Be sure rubber bushing is in engine drive housing and then install distributor. Using rotor, turn distributor shaft until offset tongue of coupling enters groove in top of oil pump drive gear.

(5) Install advance arm washers and capscrews. Install distributor cap. Install spark plug cables, high tension cable to the coil, and primary lead to coil.

(6) Check engine timing (para 4-36).

**4-37. Spark Plugs**

*a. Removal.* Disconnect the spark plug leads from the spark plugs. Clean the area of the cylinder head around the plugs. Use a spark plug socket wrench to remove spark plugs.

*b. Cleaning and Removal.*

(1) Clean the exterior of the spark plugs with a cloth dampened with a cleaning solvent. Use a sandblast type cleaner, if available, to clean the electrodes.

(2) Inspect the spark plugs for cracked insulation and burned electrodes.

(3) Test the spark plugs on a high-voltage tester. A hot, blue spark must arc across the electrodes during the test. Replace shorted plugs.

(4) If spark plugs are suitable for reuse, check and adjust the spark plug gap. Check the gap on new or used spark plugs with a round feeler gage. Refer to figure 4-32. The required gap is 0.025 inch. Adjust the gap to this dimension, if necessary, bending the side electrode only.



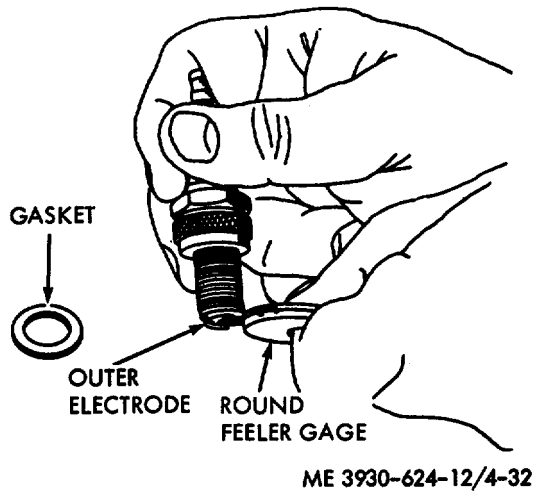

Figure 4-32. Spark plug gap.

c. *Installation.* Install the spark plugs using new gaskets. Tighten to a torque of 25 to 30 ft-lbs. Connect the spark plug leads to the spark plugs.

#### 4-38. Ignition Coil

a. *Testing.* To test the ignition coil, pull the high tension lead from the center contact of the distributor. Hold the lead by the insulation so that the terminal end is within 1/4 inch of an unpainted, grounded portion of the engine. Turn the ignition switch to START and push the starter button. A hot spark should jump from the high tension terminal to ground as the engine is cranked. If no spark is visible, and all wiring is intact, replace the coil.

##### b. Removal

(1) Tag and disconnect the electrical leads from the ignition coil.

(2) Remove the two capscrews and lockwashers securing the coil to the engine as shown in figure 4-33. Remove ignition coil.

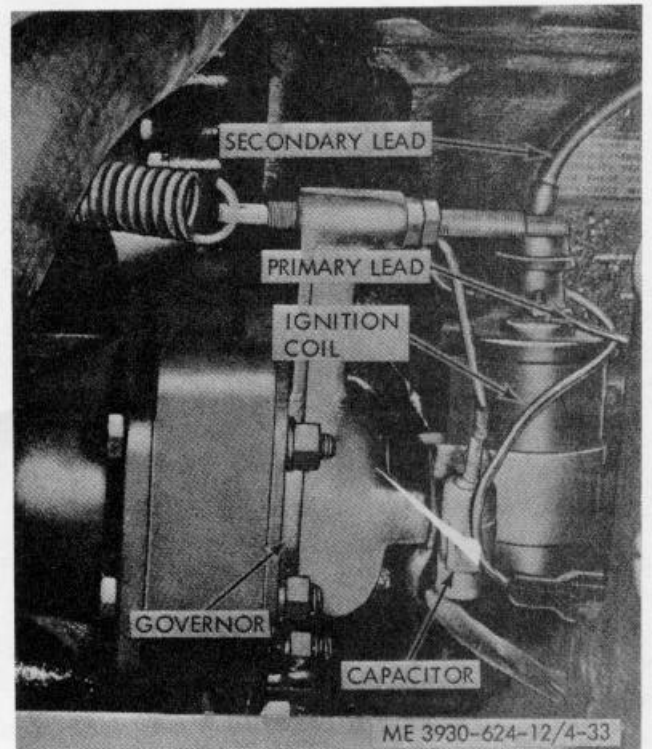

Figure 4-33. Ignition coil.

c. *Installation.* Install the ignition coil using the direct reversal of the removal procedure. Connect all electrical leads to the ignition coil.

#### 4-39. Battery and Cables

##### a. Battery Cleaning.

(1) Lift the operator's seat to obtain access to the storage battery (fig. 4-34).

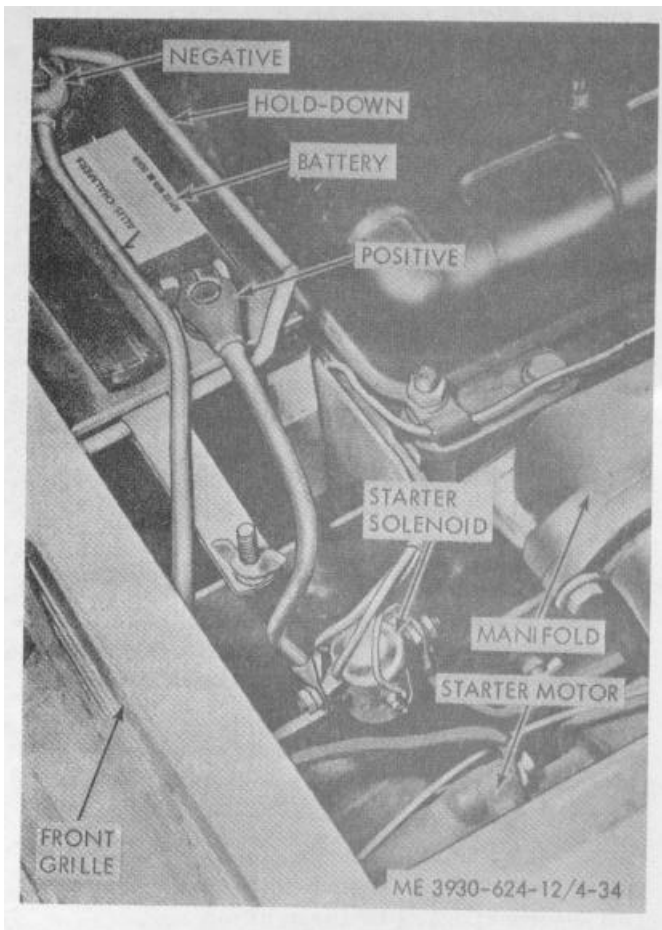

Figure 4-34. Battery location.

(2) Remove dirt and grease accumulated on the battery with a clean cloth.

(3) Pour a solution of baking soda and water on the battery to neutralize any acid present. Continue to pour until the solution no longer bubbles when it contacts the battery.

**Caution:** Remove the negative cable first. When installing cables install the negative cable last.

(4) Loosen the nuts that secure the battery cables to the battery posts; remove the cables. Clean all corrosion from the cable clamps and posts with a wire brush. Reattach the cables; tighten the nuts.

(5) Lightly coat the battery posts and cable clamps with petroleum jelly.

*b. Battery Testing.*

(1) Test the state of the electrolyte using a hydrometer. The specific gravity of the electrolyte at 75° F should be 1.225 minimum for normal temperature operation, or 1.265 minimum for cold temperature operation. For constant operation in above freezing temperatures, electrolyte strength may be reduced to 1.225 by diluting with distilled water. If the battery is not fully charged, charge it.

(2) Connect a voltmeter across the terminals of the battery, and note the reading. Pull the high tension cable from the ignition coil, crank the engine with the starter, and note the reading on the voltmeter. If the difference between the two is more than 4 volts or the second reading is less than 8 volts, replace the battery.

*c. Battery Removal.*

(1) Loosen the nuts (fig. 4-34) that secure the battery cables to the battery posts; remove the cables.

(2) Remove the two wing nuts from hold-down studs and remove battery hold-down. Remove the battery.

*d. Cleaning and Inspection.*

(1) Clean the battery tray and hold-down by flushing with a solution of baking soda and water. Flush parts until bubbling stops when new solution is applied.

(2) Inspect the battery for loose posts, cracks, evidence of leaks, or other damage.

*e. Installation.* Install battery by reversing the removal procedure.

*f. Cable Removal.* (fig. 4-34).

(1) Loosen the nuts that secure the cables to the battery posts; disconnect the cables. Remove the cable clamp that secures the cables to the truck frame.

(2) Remove the starting motor mounting bolt and lockwasher that secure the negative cable to the frame of the truck; remove the cable.

(3) Remove the nut and washer that secure the positive cable to the starter solenoid; remove the cable.

*g. Cleaning and Inspection.*

(1) Clean the cables with a rag dampened with a cleaning solvent. Clean cable clamps and lugs with a wire brush.

(2) Inspect the cables for cracked insulation, breaks, or other damage.

(3) Inspect cable clamps and lugs for corrosion, distortion, poor connections to cables, or other damage.

(4) Replace the cables if defective.

*h. Cable Installation.* Install cables by using the direct reversal of removal procedure.

**4-40. Instrument Panel**

*a. Removal and Disassembly.*

**Warning:** Disconnect the negative battery cable from the battery before disconnecting electrical leads from the controls and instruments on the instrument panel.

(1) From beneath the right hand side of the instrument panel, disconnect the male line connector.

(2) At the front of the panel, insert a screwdriver under the edge of the instrument panel at the lock pins, and pry the panel away from the pins. Refer to figure 4-35.

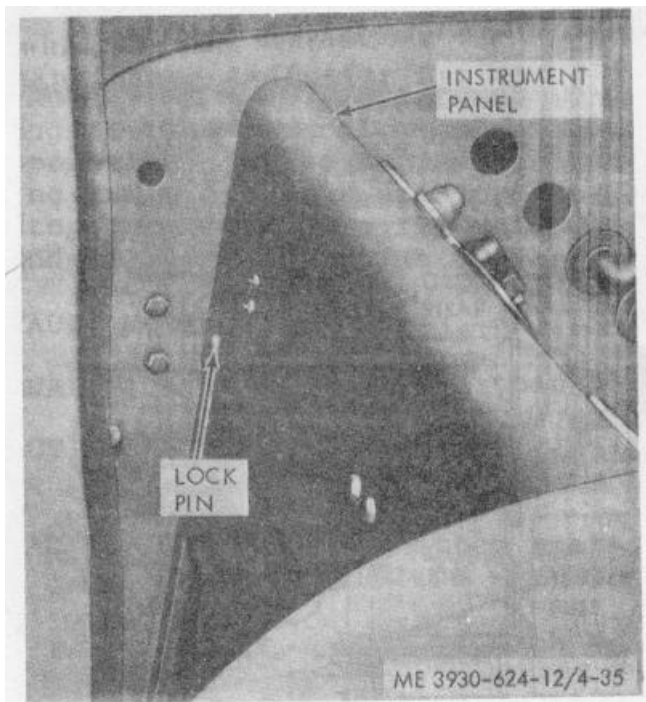

Figure 4-35. Unlocking instrument panel from lock pins.

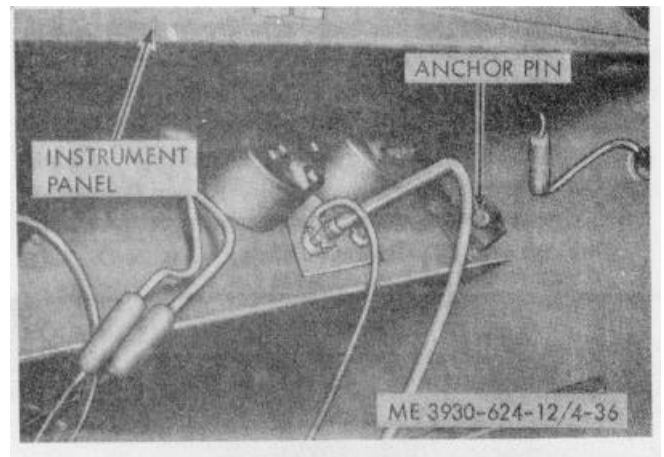

Figure 4-36. Instrument panel anchor pins.

**Caution:** Before removing anything from the instrument panel be sure to tag all electrical leads to ensure their correct installation.

(4) Remove any of the units from the instrument panel as necessary for replacement. Refer to figure 4-37.

(3) Swing the instrument panel back and down to release it from the anchors on the side panels, and lift the assembly from the truck (fig. 4-36)

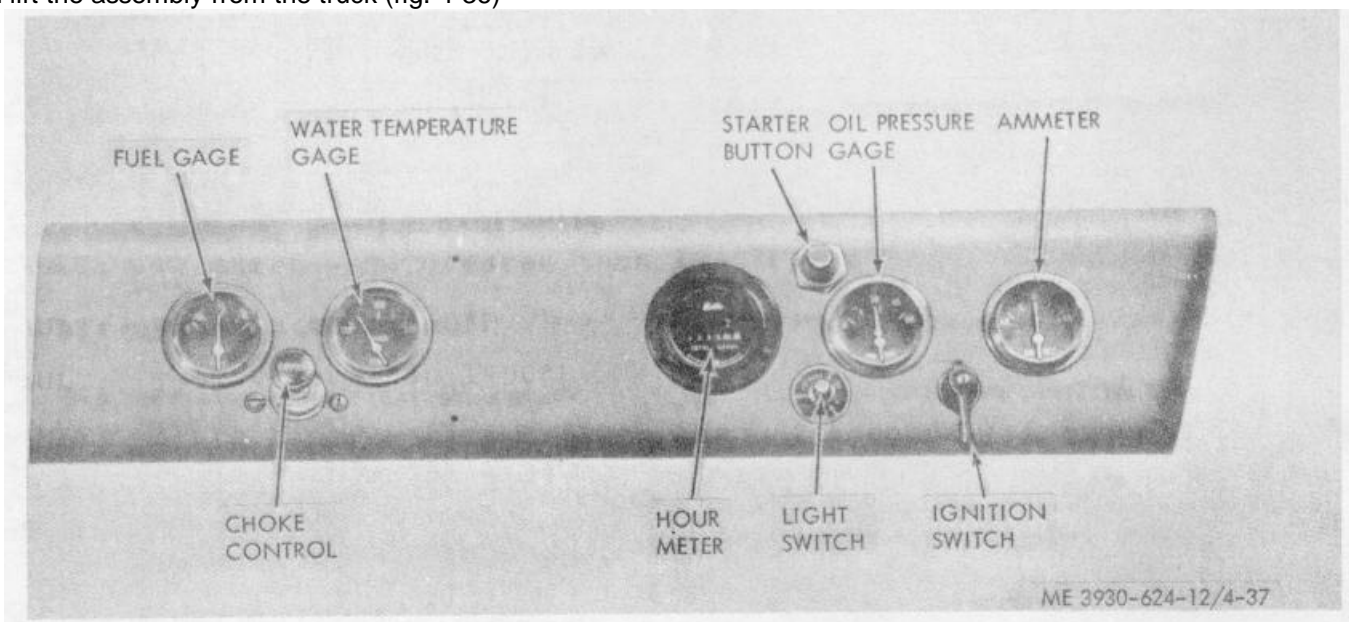

Figure 4-37. Instrument panel gauges, meters, and switches.

**b. Cleaning and Inspection.**

(1) Clean the meters, gages, and switches with a cloth dampened with a cleaning solvent. Take care to prevent the solvent from entering the parts.

(2) Clean all other parts with solvent and dry thoroughly.

(3) Inspect meters and gages for cracked glass, illegible dial faces, damaged terminals, and other damage.

(4) Inspect the switches for binding operation, damaged terminals, signs of overheating, damaged threads or other defects; replace faulty switches.

(5) Inspect the instrument panel for cracks, dents, distortion, and other damage; replace damaged instrument panel.

c. *Reassembly and Installation.*

(1) Reinstall gages, meters, and switches that were removed during disassembly of the instrument panel.

(2) Install the leads that were disconnected from the instruments, following the instructions on the tags that were installed at the time of disassembly. If any tags were destroyed, refer to the wiring diagram, figure 1-3, to determine the connection requirements.

(3) Install the instrument panel using the direct reversal of the removal procedure.

**4-41. Lights**

a. *Removal*

(1) To remove the headlight (fig. 4-38), disconnect the electrical lead. Remove the knob, nut and washer securing the headlight to the bracket. Remove the headlight.

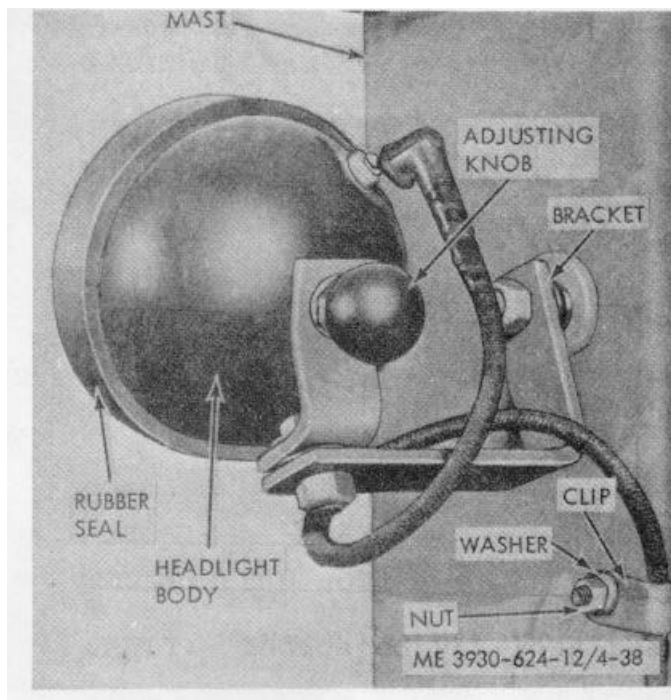

Figure 4-38. Headlight assembly.

(2) To remove the stop and taillight, tag and disconnect the electrical leads. Remove the nut and washer (fig. 4-39) securing the light to the bracket; remove the taillight.

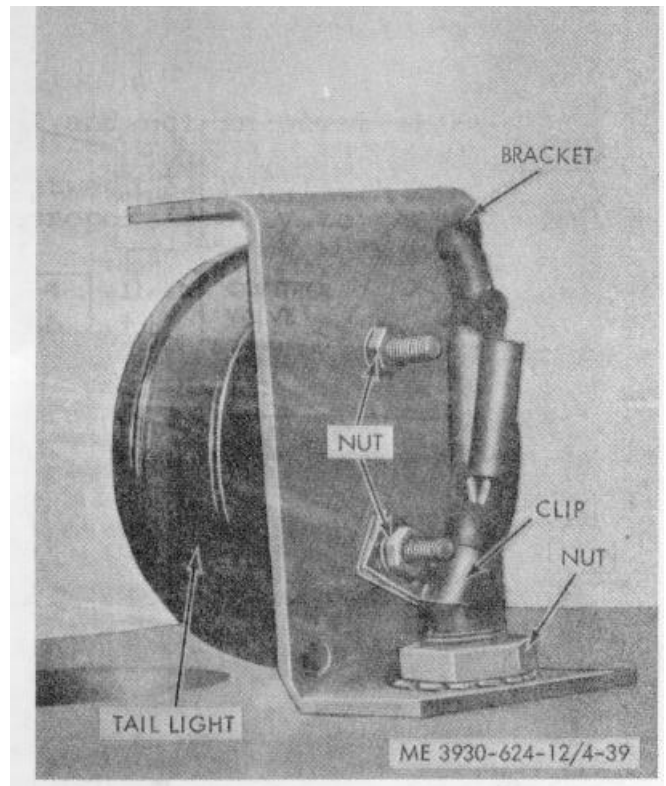

Figure 4-39. Taillight assembly.

b. *Cleaning and Inspection.*

(1) Clean all parts with a cloth dampened with a solvent; dry thoroughly.

(2) Inspect parts for cracks, distortion, corrosion, and other damage; replace damaged parts.

c. *Installation.* Install the headlight and taillight assemblies using a direct reversal of the removal procedures.

d. *Lamp Replacement.*

(1) To install the headlight lamp, remove the rubber seal that holds the sealed lamp assembly into the body. Remove and disconnect the sealed lamp. Reverse the procedure to install a new lamp.

(2) To remove the tail-lamp, remove the retaining ring (fig. 4-39) and lens from the body. Push in on the lamp and give it a one-quarter turn counterclockwise to remove it. Reverse the procedure to install a new lamp.

#### 4-42. Horn

##### a. Removal.

(1) Tag and disconnect electrical leads to the horn.

(2) Remove the two nuts and lockwashers securing the horn to the mounting bracket. Remove the horn. Refer to figure 4-40.

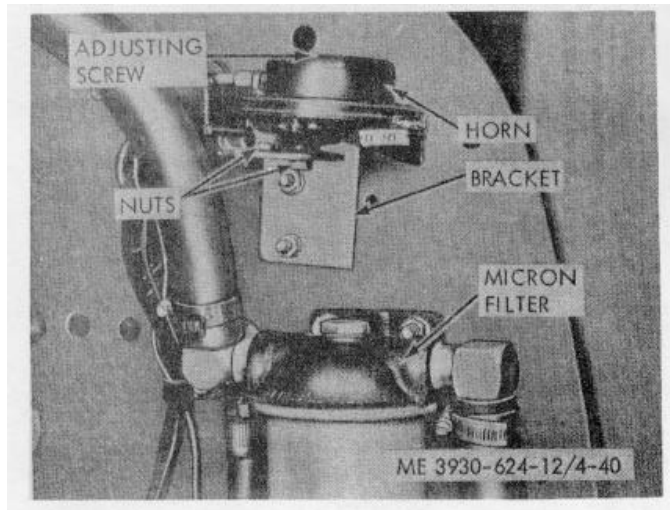

Figure 4-40. Horn mounting and adjusting screw.

##### b. Cleaning and Inspection.

(1) Clean the horn with a cloth dampened with a solvent.

(2) Check the horn for cracks, corrosion, and other damage. Replace the horn if damaged.

c. *Installation.* Install in the reverse order of removal.

##### d. Adjustment.

(1) If the horn produces a weak signal, connect a voltmeter from the ground to the horn

terminal. Press horn button and note the voltage. If the voltage is between 0 and 10.7 volts, replace the horn.

(2) If the horn signal is weak and the voltage is normal at the horn terminal, check the volume adjusting screw in horn cover (fig. 4-40). Turn the screw clockwise to increase the volume or counterclockwise to decrease the volume.

#### 4-43. Horn Relay

a. *Removal.* Remove two nuts, washers, and capscrews securing the horn relay to the bracket. Tag and disconnect wiring. (Refer to fig. 4-41.)

##### b. Cleaning and Inspection.

(1) Clean the relay housing with a cloth dampened with a solvent.

(2) Check the relay assembly for corrosion, dents, cracks, or other damage. Replace if necessary.

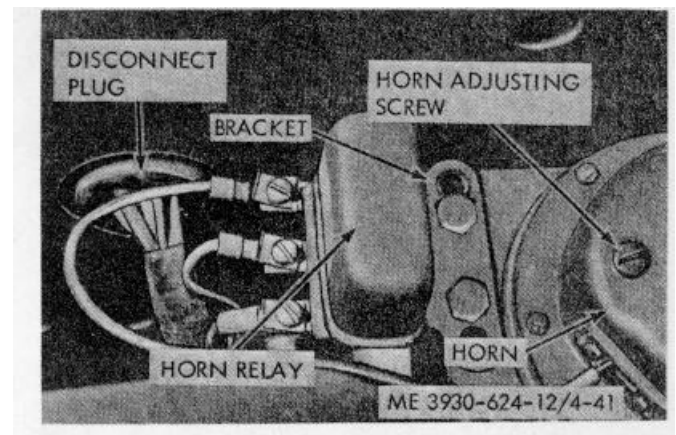

Figure 4-41. Horn relay.

c. *Installation.* To install horn relay, reverse the removal procedure.

## Section XII. MAINTENANCE OF THE TRANSMISSION

#### 4-44. General

a. The transmission is mounted between the engine and the drive axle assembly, immediately below the operator's seat. The transmission is connected to the torque converter on one end, and to the universal joint on the other. It is a constant mesh, full reversing, power shift type. The forward and reverse directions are selected by positioning the power shift lever mounted on the steering column. The power shift lever is connected by a mechanical linkage to the selector valve on the transmission.

b. The transmission fluid is cooled by a heat exchanger located in the lower part of the radiator. The fluid is pumped from the transmission, through the

heat exchanger and back to the transmission.

#### 4-45. Transmission Oil Lines and Filter

##### a. Filter Service.

(1) To change the transmission fluid, run the truck to warm the fluid to operating temperature. Drain the fluid by removing the transmission drain plug from the bottom of the transmission (fig. 4-42). Drain fluid from torque converter by removing the floor plate, and the inspection cover from the torque converter housing. Remove the drain plug. Rotate the torque converter 180°. The fluid in the converter will flow into the transmission, and will drain from the transmission drain plug.

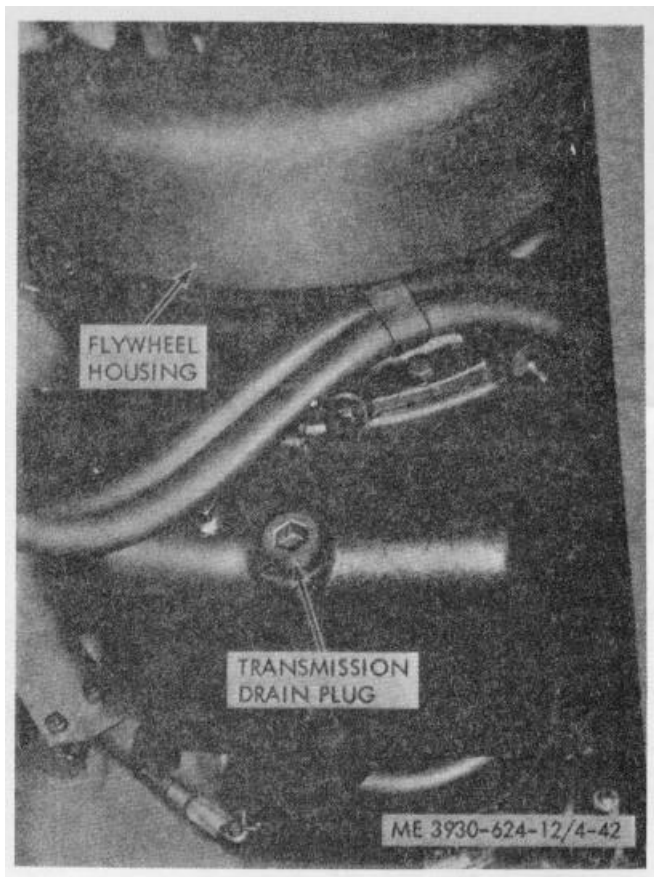

Figure 4-42. Transmission drain plug.

(2) Change the transmission oil filter element to coincide with the transmission fluid change. When the fluid has drained, remove the transmission oil filter element (fig. 4-43) by turning it counterclockwise.

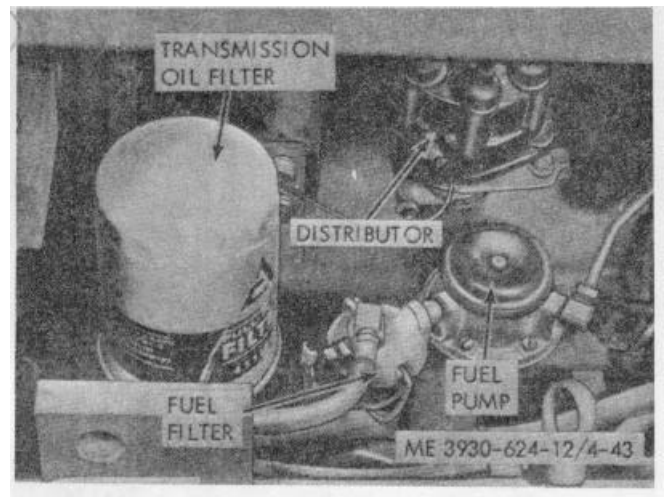

Figure 4-43. Transmission oil filter element.

(3) Install a new element and gasket, tightening hand-tight only.

(4) Reinstall the drain plug in the bottom of the transmission. Rotate the torque converter, install the drain plug and inspection cover. Fill the transmission with fresh transmission fluid of the proper grade. Fill until level is to the FULL mark on the dipstick.

(5) Run engine in neutral until normal operating temperature is reached. The fluid will pass into the torque converter from the transmission. Recheck the fluid level. Fill as necessary to full mark on dipstick.

*b. Removal and Disassembly.* Remove the hoses at the filter. Remove the loop clamps from the hose assembly (6) and remove the hose assembly. Refer to figure 4-44 and disassemble as required.

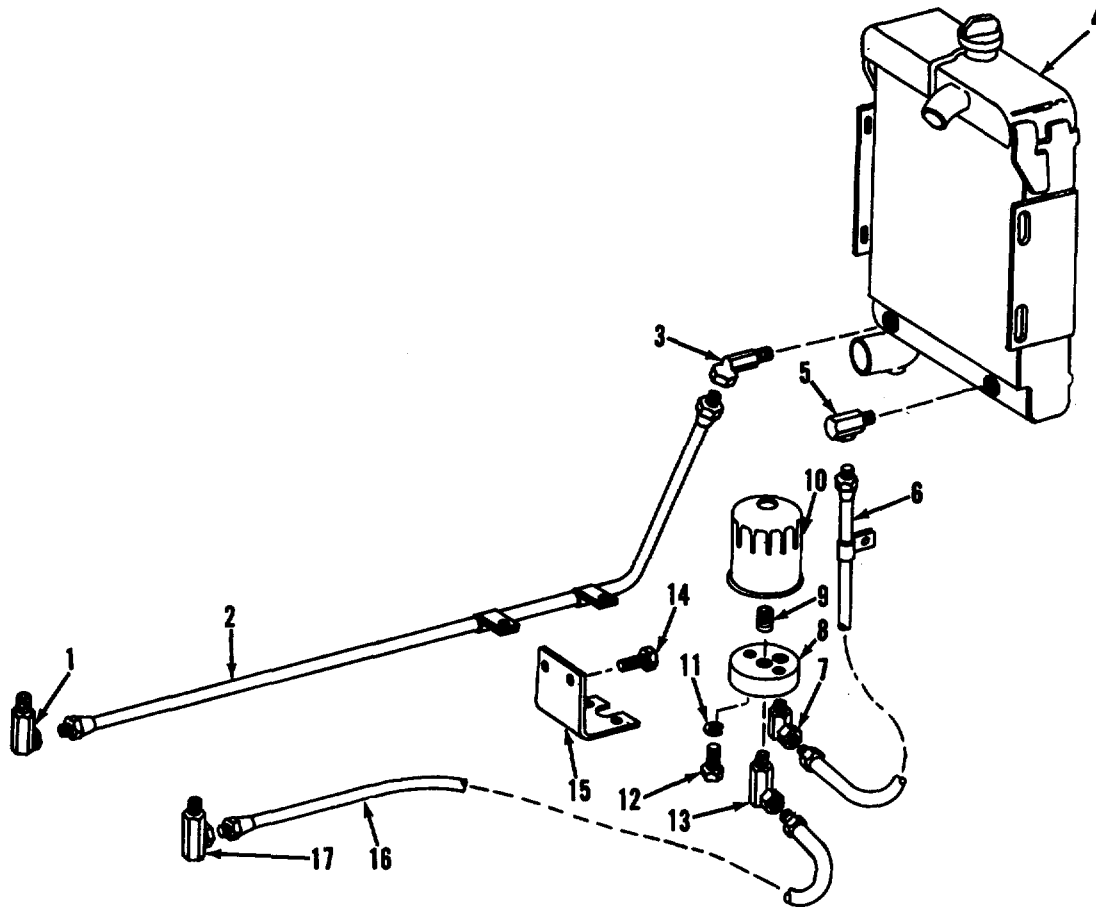

ME 3930-624-12/4-44

- |                  |                   |
|------------------|-------------------|
| 1. 90° elbow     | 10. Filter        |
| 2. Hose assembly | 11. Washer        |
| 3. 45° elbow     | 12. Screw         |
| 4. Radiator      | 13. 90A elbow     |
| 5. 90° elbow     | 14. Bolt          |
| 6. Hose assembly | 15. Bracket       |
| 7. 90° elbow     | 16. Hose assembly |
| 8. Filter base   | 17. Elbow         |
| 9. Nipple        |                   |

Figure 4-44. Transmission lines, fittings, and filter.

*c. Cleaning and Inspection.*

(1) Discard and replace the filter element.

(2) Wipe the exterior of the hoses with a cloth dampened with a cleaning solvent. Pour clean solvent through the hoses to flush them out. Blow clean, dry compressed air through the hoses to assure that they are free and clear. Clean all other parts with solvent.

(3) Inspect the filter base for cracks, damaged threads, scratched or scored filter seat, and other damage; replace a damaged filter base.

(4) Inspect the hoses for cracks, deterioration, abrasions, and damaged threads; replace damaged hoses.

(5) Inspect all other parts for cracks, distortion, and damaged threads; replace damaged parts.

*d. Reassembly and Installation.* Reinstall the 4-39 transmission lines and fittings by reversing the removal procedure. Install a new filter element and gasket. Fill the transmission with fresh fluid to the proper level. After installation, start the engine and carefully check for oil leaks. Repair any oil leaks and add oil as necessary.

## Section XIII. MAINTENANCE OF SHAFTS AND AXLES

### 4-46. Propeller Shafts

#### a. Removal.

(1) Remove wires and socket head capscrows holding universal joints to the pinion shaft flange and slip joint. Refer to figure 4-45.

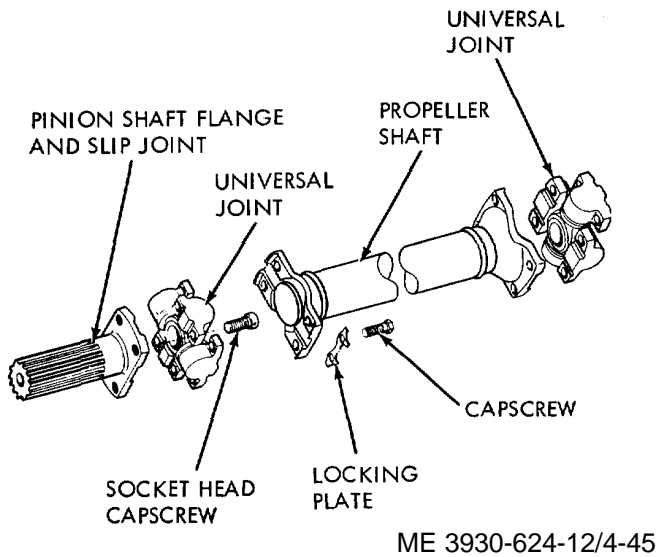

Figure 4-45. Universal joint and propeller shaft.

(2) Slide the output shaft slip joint into the transmission and remove the propeller shaft assembly.

(3) Bend back clips on a capscrow locking plates and remove both universal joints.

(4) If necessary remove slip joint from transmission.

b. Servicing. To pack the universal joints with lubricant proceed with the following steps.

**Caution:** All parts of the universal joint and propeller shaft assembly should be cleaned thoroughly before assembly. Abrasives are very harmful to this assembly.

(1) After the universal joints have been removed from the truck, break connecting plate tying the trunnion bearings together. These connecting plates need not be replaced.

(2) Inspect all bearings and surfaces for irregularities and replace damaged parts.

(3) Pack the trunnion bearings thoroughly with a high melting point wheel bearing or universal joint grease. Make sure grease fully covers bearing surfaces.

(4) To reassemble, reverse the removal procedure. It is recommended that the capscrow locking plates be replaced.

c. Installation. To install the drive shaft, reverse the removal procedure.

### 4-47. Drive Axle Assembly

The drive axle and bearings should be lubricated at periodic intervals in accordance with the current lubrication order. All parts should be checked for possible damage and excessive wear.

### 4-48. Differential

The oil level in the differential housing should be checked periodically and changed as specified in the current lubrication order.

## Section XIV. MAINTENANCE OF THE BRAKES

### 4-49. General

The parking brake is a dual shoe mechanical brake, mounted on the drive shaft, and can be used either as a parking brake or an emergency brake. The brake shoes are actuated through a cable by an adjustable over-center type lever mounted on the left hand cowl panel. A service brake is mounted on each of the drive wheels. The service brakes are operated by hydraulic pressure. The brake drum rotates on the end

of the drive axle, and the shoe assemblies are mounted on the backing plate.

### 4-50. Parking Brake

#### a. Removal.

(1) Remove the floor plate.

(2) Remove the clevis pin from the yoke and remove the yoke from the brake lever (fig. 4-46).



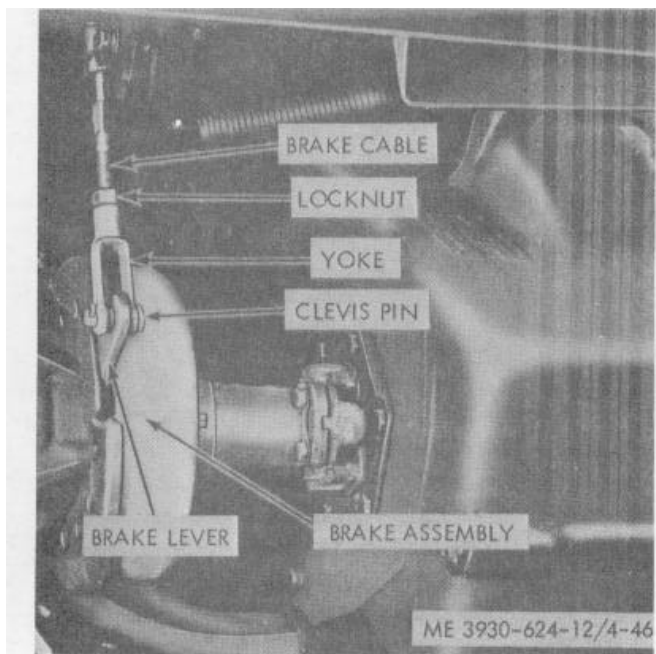
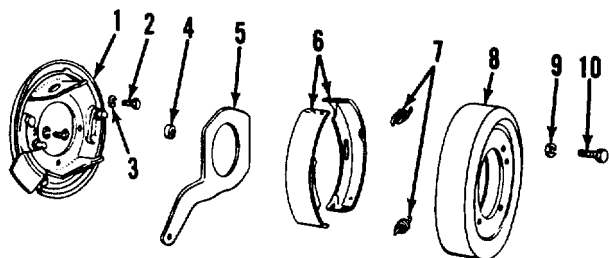

Figure 4-46. Parking brake removal.

- (3) Remove universal joint (para 4-46).
- (4) Remove the lockwire securing capscrews (10, fig. 4-47) and remove the four capscrews and lockwashers.



ME 3930-624-12/4-47

- |                  |                      |
|------------------|----------------------|
| 1. Backing plate | 6. Shoe and lining   |
| 2. Capscrew      | 7. Spring, centering |
| 3. Lockwasher    | 8. Drum              |
| 4. Roller        | 9. Lockwasher        |
| 5. Lever         | 10. Capscrew         |

Figure 4-47. Parking brake assembly.

- (5) Carefully slide brake drum (8) off the backing plate ( 1 ) taking care not to nick or damage the drive shaft.

- (6) Remove the two centering springs (7) and remove the brake shoes and linings (6).
- (7) Remove lever (5) and rollers (4).
- (8) Remove capscrews (2) and lockwashers (3) and remove backing plate (1).

b. *Installation.* Install the parking brake assembly by using the direct reversal of the removal procedure.

c. *Parking brake adjustment.*

- (1) Set the hand brake lever in the fully released position.
- (2) Remove the setscrew that locks the adjusting knob in position as illustrated in figure 4-48.

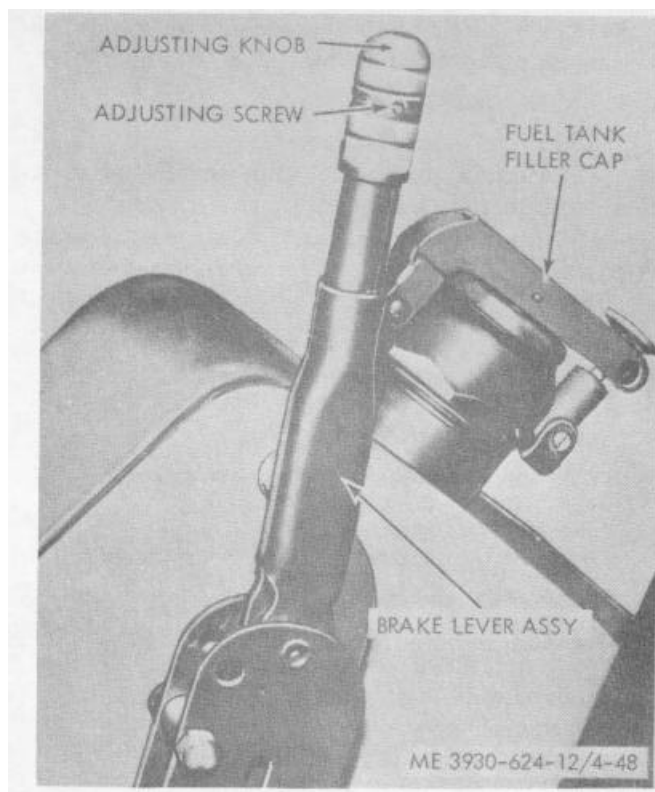

Figure 4-48. Hand brake adjustment.

- (3) Turn the adjusting knob in a clockwise direction one or two turns. Check the adjustment by engaging the brake.
- (4) Repeat step 3 if necessary; otherwise install the setscrew in the adjusting knob to prevent loss of adjustment.

d. *Brake Shoe Adjustment.* If the adjusting knob on the parking brake handle will no longer correct the brake adjustment, and sufficient brake lining is still available, further adjustment is made at the lower brake cable yoke (1) Remove the adjusting knob lock screw from the parking brake handle and back off the

knob four or five turns. The handle must be in the fully released position.

(2) Remove the floor plate.

(3) Remove the clevis pin from the yoke and loosen the yoke locknut (fig. 4-46).

(4) Rotate the yoke three or four turns in a clockwise direction to shorten the length.

(5) Install the yoke on the brake lever and check the adjustment by engaging the hand brake handle. If necessary, make further adjustment to the yoke to make certain the brake shoes do not drag when disengaged.

(6) After satisfactory adjustment is made, tighten the yoke locknut, install the cotter pin in the yoke clevis pin. Install the locking screw in adjusting knob of the parking brake handle.

#### 4-51. Service Brakes

##### a. Removal and Disassembly.

(1) Remove the wheel and wheel bearing at described in paragraph 4-55.

(2) Remove the dust shield to expose the brake components for service. Refer to figure 4-49.

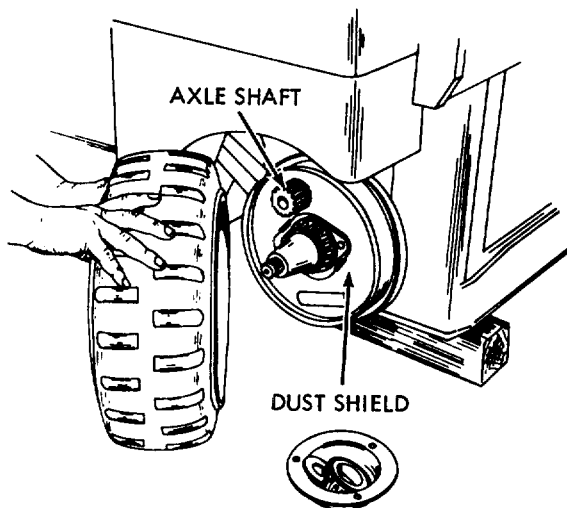

Figure 4-49. Dust shield.

(3) Remove the upper and lower shoe return springs (fig. 4-50).

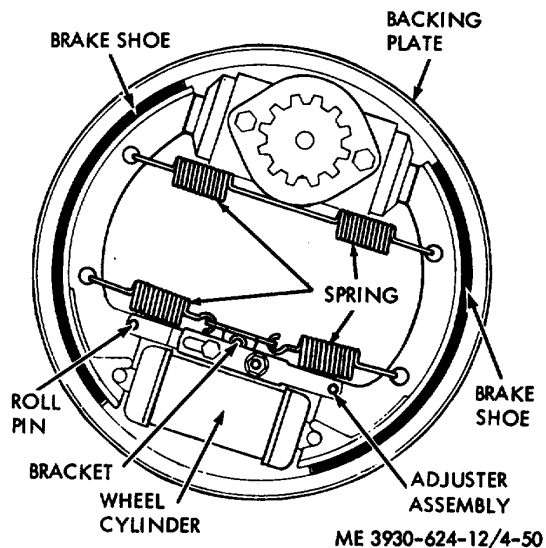

Figure 4-50. Self-adjusting brakes.

(4) Remove the brake shoes and adjuster assembly as a unit.

**Note.** The adjuster assembly must be compressed to disassemble the self-adjusting brakes. This compression of the adjuster assembly will not affect the adjustment of the brakes.

(5) Drive out the roll pins which attach the adjuster assembly to the brake shoes. Compress the adjuster assembly by placing one end on a solid surface and tapping the other end with a wooden mallet until it is fully compressed.

##### b. Cleaning and Inspection.

(1) Clean the brake shoes with a wire brush. Remove greasy or gummy deposits with a cloth dampened with a cleaning solvent.

(2) Wipe the exterior of the wheel cylinder with a cloth dampened with a cleaning solvent.

(3) Clean all metallic parts with cleaning solvent; dry thoroughly.

(4) Inspect the brake shoes for wear, cracks, oil saturation, or other damage. If the linings are damaged or worn to less than 1/16" thickness, replace the brakeshoes.

(5) Inspect the wheel cylinders for cracks,

deterioration of rubber parts, signs of leaking, or other damage; replace damaged wheel cylinders.

(6) Inspect the brake return springs for cracks, worn or damaged end hooks, or elongation. If the springs are damaged or if they are elongated so that spaces exist between loops of the springs, replace the springs.

(7) Inspect the backing plate for cracks, distortion, and other damage; replace authorized parts.

**Note.** The brake drum is an integral part of the drive wheel.

(8) Inspect brake drum interior for scoring, charring, or uneven wear. Replace the brake drum as directed in paragraph 4-55.

*c. Reassembly and Installation.*

(1) Attach the adjuster assembly to the brake shoes with the roll pins.

(2) Make certain the backing plate is secured tightly to the axle.

(3) If self-adjusting link is inadvertently disassembled, it must be replaced.

(4) Install the shoe and link assembly in place and install the springs. Install the wheel assembly as directed in paragraph 4-55.

#### 4-52. Brake Master Cylinder

*a. Removal.*

(1) Remove the floor plate.

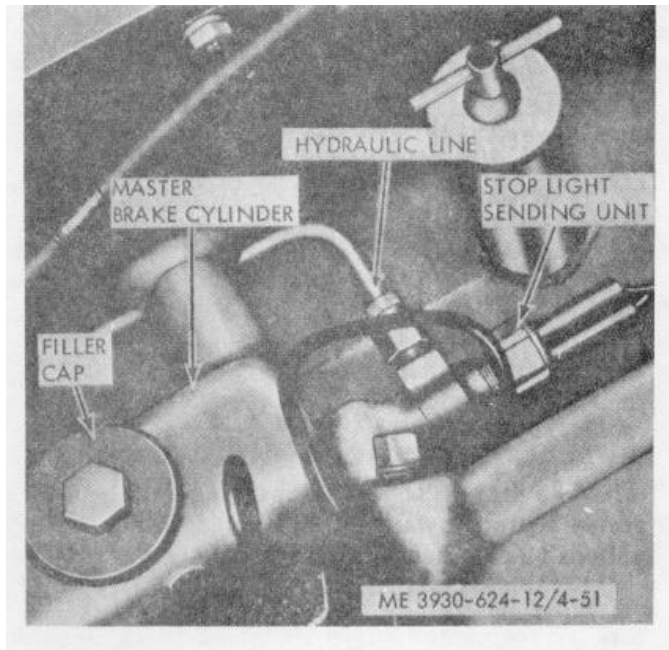

Figure 4-51. Master cylinder.

(3) Remove the clevis pin securing the push rod to the brake pedal assembly and disconnect tension spring (refer to fig. 4-52).

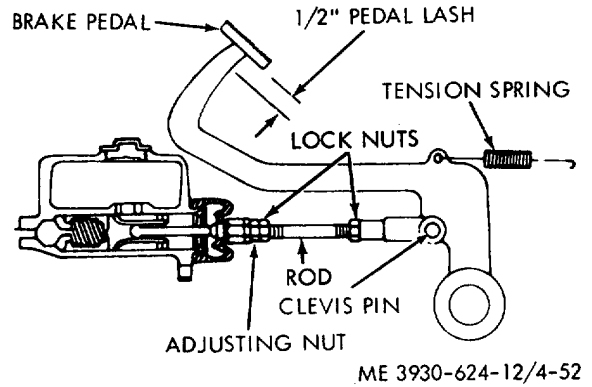

Figure 4-52. Pedal lash adjustment.

(4) Remove the capscrews holding the master cylinder to the inside of the frame and remove the cylinder.

*b. Cleaning and Inspection.*

(1) Clean exterior of master cylinder with a cleaning solvent.

(2) Inspect the master cylinder for cracks, leaks, faulty operation, or other damage; replace if damaged.

*c. Installation.* Install the master cylinder in the truck by reversing the removal procedure.

**Note.** Check to make sure engine ground strap is connected:

#### 4-53. Pedal Linkage

If the pedal linkage does not provide proper clearance between master cylinder piston and linkage with the brakes released, the piston cannot return to full off position. The brakes will drag after several applications if the by-pass port is blocked. Refer to figure 4-52. Adjust the linkage to provide 1/2 inch of free play measured at the brake pedal by loosening the locknuts and adjusting the adjusting nut. More free play will reduce the usable stroke of the master cylinder piston.

## Section XV. MAINTENANCE OF THE WHEELS

### 4-54. General

The truck is driven by the front wheels and utilizes the rear wheels for steering. The front wheels are driven by a ring gear and pinion system which provides the final speed reduction at the wheels. All wheel hubs ride on tapered roller bearings which must be cleaned and repacked with grease at the intervals indicated on the lubrication order. The tires are of the solid rubber cushion type.

### 4-55. Wheels and Tires

#### a. Removal

**Warning: Block the truck before attempting to remove the wheels.**

(1) To raise the front end of the truck for wheel and tire replacement, tilt the mast back as far as possible and install a wooden block under the mast assembly. Tilt the mast forward to raise the front of the truck. To raise the rear wheels for wheel and tire replacement, use a jack or hoist. Place blocking under the frame.

(2) Remove the bolts (1, fig. 4-53), lockwashers (2) and hubcap (3). Remove the cotter pin (4), washer (6), and retaining nut (5).

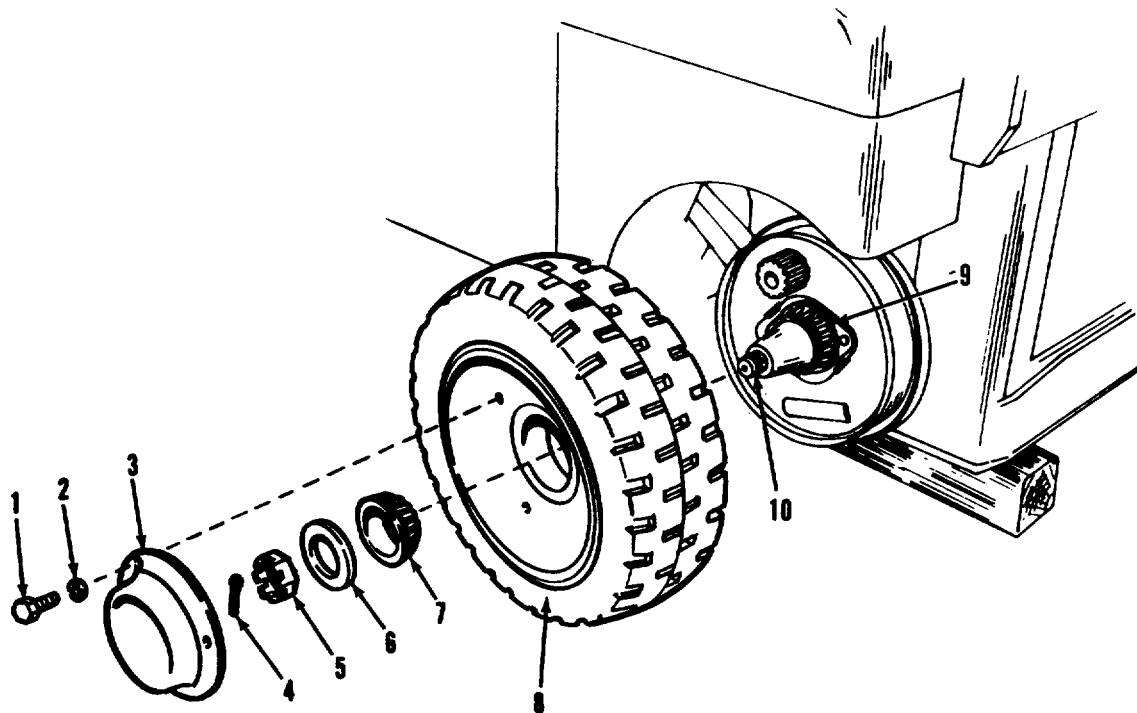

- |                  |                            |
|------------------|----------------------------|
| 1. Bolt          | 6. Washer                  |
| 2. Lockwasher    | 7. Outer wheel bearing     |
| 3. Hubcap        | 8. Wheel and tire assembly |
| 4. Cotter pin    | 9. Inner wheel bearing     |
| 5. Retaining nut | 10. Spindle                |

Figure 4-53. Wheel removal

(3) Remove the outer wheel bearing (7) and remove the wheel assembly (8).

#### b. Cleaning and Inspection.

(1) Inspect the wheels for distortion, cracks, elongated or worn mounting holes, and other damage.

(2) Inspect the tires for cuts, imbedded glass or metal, and excessive wear. Inspect for deterioration

caused by oil, grease or chemicals, and other damage. Use a sharp knife to trim around cuts, removing the edges which could catch and cause further enlargement of the damaged area.

(3) If either the wheel or tire is damaged, replace the parts as an assembly.

c. *Installation.* Install the wheel and tire assembly by reversing removal procedure. Refer to para 4-56 for torquing of wheel bearings.

#### 4-56. Wheel Bearings

##### a. *Removal and Disassembly*

**Warning:** Block the truck before attempting to remove the wheels.

(1) To raise the front end of the truck for wheel and tire replacement, tilt the mast back as far as possible and install a wooden block under the mast assembly. Tilt the mast forward to raise the front of the truck. To raise the rear wheels for wheel and tire replacement, use a jack or hoist. Place blocking under the frame.

(2) Remove the wheel and tire assembly as directed in paragraph 4-55.

(3) Remove inner wheel bearing (9, fig. 4-53).

##### b. *Cleaning and Inspection.*

(1) Clean the bearing cones by flushing up and down in a cleaning solvent. If necessary, tap the large side of the bearing against a soft wooden block to dislodge solidified grease. Dry the bearings with clean, dry compressed air. Direct the stream of air at the bearing so that the rollers and cage will not spin. Dip the bearings in light oil immediately after cleaning.

(2) Clean the hub and spindle (10) with a cloth dampened with cleaning solvent.

(3) For the drive wheels, clean the ring gear and pinion with a cleaning solvent and dry with compressed air.

(4) Inspect the bearing cones for pitting, scoring, wear, cracked cages, and for rough or binding operation. Replace damaged bearings.

(5) Inspect the bearing cups for scoring, scratches, nicks, and other damage. If damaged, drive the cups from the wheel hub using a soft drift. Press in new bearing cups, taking care not to damage the cups or hub.

c. *Packing Bearings.* Pack the bearing cones and the interior of the hub with the lubricant recommended by the lubrication order. Take care to prevent dirt or grit from contaminating the grease.

During reassembly, pack the ring gear of the drive wheels with grease.

##### d. *Reassembly.*

(1) Reassemble the bearings and hub on the spindle or steering knuckle in the reverse order of disassembly.

(2) Tighten drive wheel bearing nuts as follows. Using a torque wrench, tighten nuts (5, fig. 4-53) to a torque of 120 ft.-lbs. Just before maximum torque is applied turn wheel six times in each direction, then back nut off 300 minimum to 60 ° maximum so cotter pin can be installed. While tightening the steer wheel nut, rotate the wheel six times in each direction while torquing nut to 50 ft. lbs. Back nut off to 0 ft.-lbs., then retorque to 25 ft. lbs. while turning the wheel. Finally back nut off 30 o minimum to 60 ° maximum and install the cotter pin.

(3) Remove the blocking and lower the truck to the ground.

## Section XVI. MAINTENANCE OF THE STEERING SYSTEM

#### 4-57. General

The rear wheels are used to steer the truck. Steering is done by a steering handwheel through the steering valve, power steering cylinder, and the steer axle. The steer axle is located beneath the engine at the rear of the truck. The steering valve is mounted on the chassis in front of the operator. Through the power steering cylinder and pivot arm, the operator can turn the steer wheels to control the direction of the truck.

#### 4-58. Tie Rods

##### a. *Removal and Disassembly.*

(1) Remove the cotter pin and loosen the adjusting plug in the end of the tie rod. Remove the tie rod from the pivot arm. (fig. 4-54.)

(2) Remove the cotter pin nut and washer from the tie rod at the steering knuckle. Refer to figure 4-55.

(3) Disassemble as shown in figure 4-56.

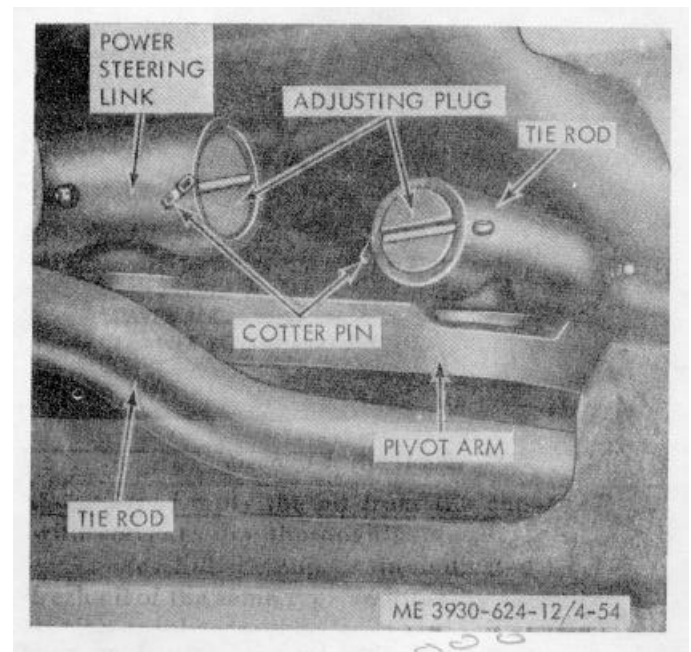

Figure 4-54. Tie rod removal (pivot arm end).

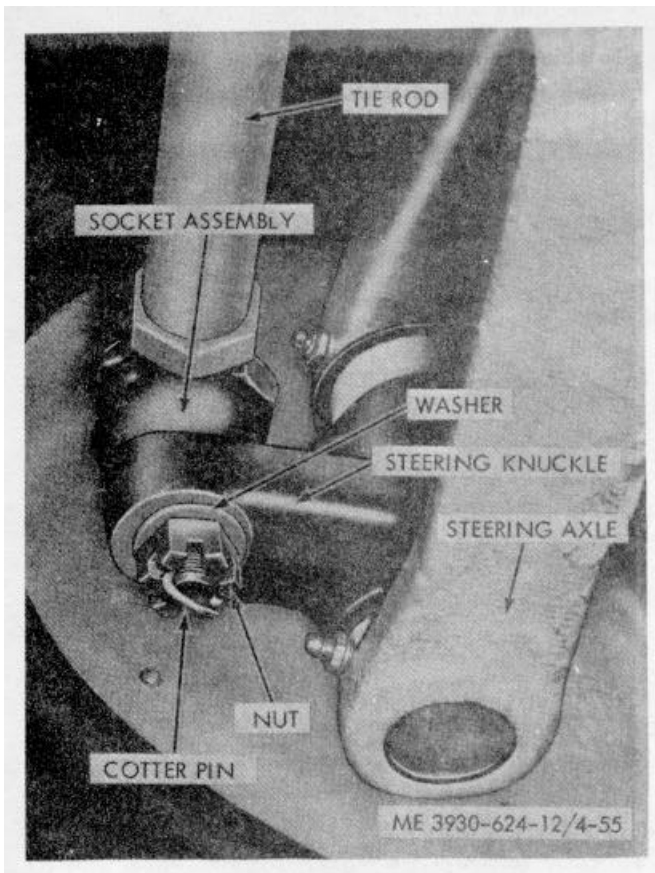
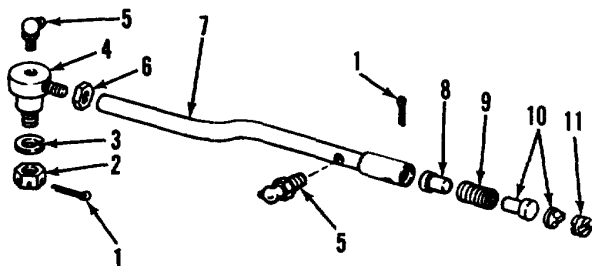

Figure 4-55. Tie rod removal (steering knuckle end).



- |                    |                    |
|--------------------|--------------------|
| 1. Cotter pin      | 7. Tie rod         |
| 2. Nut             | 8. Plug            |
| 3. Washer          | 9. Spring          |
| 4. Socket assembly | 10. Ball seats     |
| 5. Grease fitting  | 11. Adjusting plug |
| 6. Adjusting nut   |                    |

Figure 4-56. Tie rod assembly.

*b. Cleaning and Inspection.*

(1) Wipe the tie rod ends with a cloth dampened with a cleaning solvent. Clean all remaining parts with solvent and air dry.

(2) Inspect the tie rod ends for damaged threads, binding or seizing of the studs, scoring or corrosion. If tie rods are bent or damaged, they are to be replaced.

*c. Reassembly, Installation and Adjustment.*

(1) Reassemble the locknuts and tie rod ends on the tie rods. Do not tighten the locknuts until the tie rod length is adjusted.

(2) To adjust the tie rods, raise the truck with a jack under the counter-weight to raise the steering wheels from the floor. Disconnect the power steering cylinder from the pivot arm assembly, as directed in paragraph 4-59.

(3) Place the wheels in a straight ahead position, so that they will track with the drive wheels. Install the tie rods between the steering knuckles and the pivot arm assembly. If one wheel remains in a straight position and the other is turned slightly in or outward, adjust the tie rod of the wheel that is not straight, as zero degrees toe-in must be maintained at all times.

(4) To adjust the tie rod (fig. 4-56) loosen the adjustment plug and remove the rod from the pivot arm assembly. Swing the tie rod away from the steer axle. Align the steer wheel so that they are parallel with the side of the truck. Turn the tie rod on to the ball socket to shorten the tie rod, or turn the rod off of the ball socket to lengthen the tie rod.

(5) After the correct adjustment has been achieved, tighten the locknuts and replace the tie rod on the pivot arm assembly. Tighten the adjustment plug (refer to fig. 4-56 and 4-54).

(6) Adjust and install the steering cylinder as directed in paragraph 4-59.

**4-59. Power Steering Cylinder**

*a. Removal. (fig. 4-57).*

(1) Remove the inlet and outlet lines from the power steering cylinder; allowing the lines and cylinder to drain into a container of suitable size.

Plug the ends of the lines and the cylinder ports to keep out foreign matter.

(2) Disconnect ball socket connecting the power steering cylinder to the pivot arm, by removing the cotter pin and loosening the adjusting plug (fig. 4-54).

(3) To disconnect the front end of cylinder from the frame, remove the cotter pin securing shaft pin in bracket.

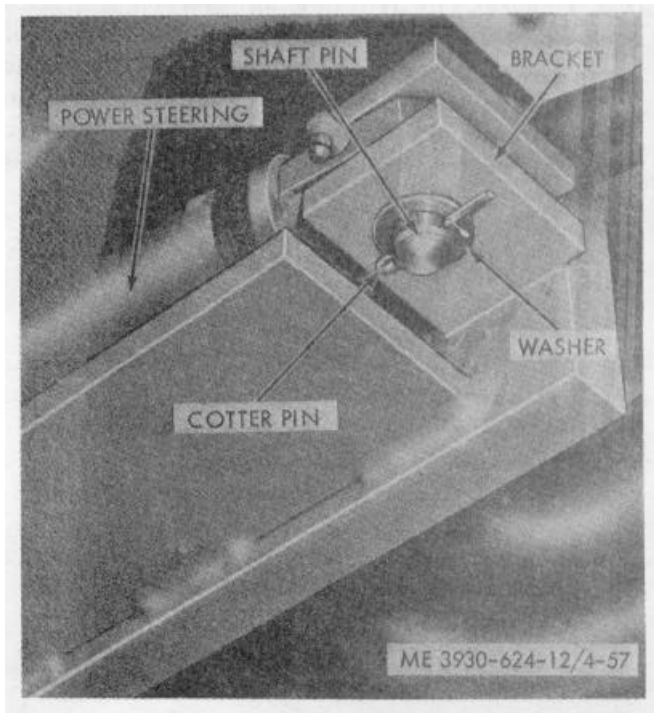

Figure 4-57. Power steering cylinder removal.

*b. Cleaning and Inspection.*

(1) Clean the outside of cylinder with a cloth dampened with cleaning solvent.

(2) Inspect cylinder for cracks, leaks, dents, distortion, corrosion, and other damage. Replace the power steering cylinder if damaged.

*c. Installation.* Install the power steering cylinder by reversing the removal procedure.

**Section XVII. MAINTENANCE OF HYDRAULIC LIFT COMPONENTS**

**4-60. General**

The lift and tilt cylinders are operated by means of hydraulic pressure. The hydraulic lift components described in this section consist of the following; tilt cylinder, lines and fittings, oil reservoir, oil filter and oil reservoir breather.

**4-61. Tilt Cylinder**

*a. Adjustment.*

(1) Use a protractor to obtain the proper degree of mast tilt.

(2) Set the protractor at 8° and place the protractor on the back of the mast. Tilt the mast to the end of the backward stroke. Refer to figure 4-58.

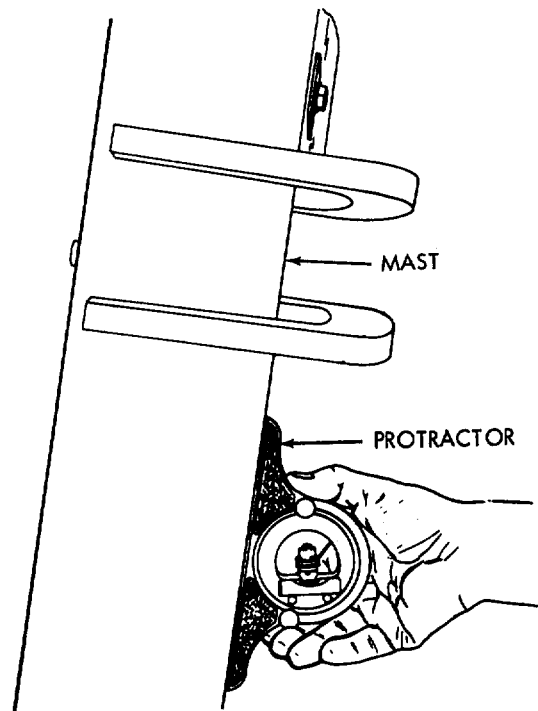

Figure 4-58. Checking mast tilt angle.

(3) The bubble in the level of the protractor should center if the degree of backward tilt is correct.

**Note. Check both the right and the left side of the mast assembly and at the same time make sure both cylinders have bottomed.**

(4) If adjustment is necessary, tilt the mast to the forward position and loosen the capscrew on the tilt cylinder clevis. Loosen the hex nut and place a wrench on the adjusting hex on the tilt cylinder rod and, turn in or out of the clevis to obtain the proper adjustment (fig. 4-59). Tighten lock nut.

(5) After each adjustment, check the degree of tilt. When the proper degree of tilt is obtained tighten the capscrews at the yoke.

(6) The forward tilt angle is automatically adjusted when the backward tilt is set.

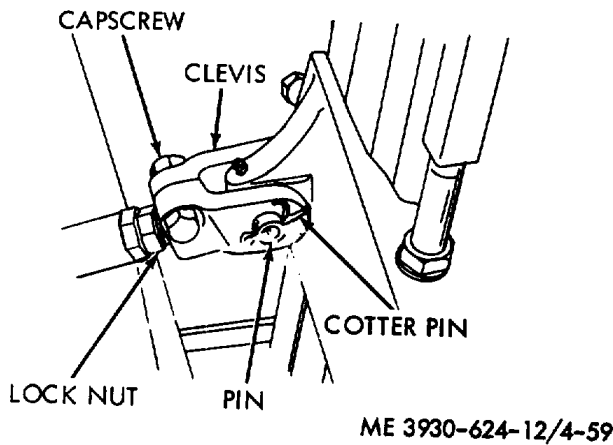

Figure 4-59. Tilt cylinder yoke.

#### 4-62. Lines and Fittings

##### a. Inspection.

- (1) Inspect all fittings for damaged or stripped threads.
- (2) Inspect clamps for cracks, stripped threads, perforated bands, or other damage.
- (3) Inspect flexible lines for soft spots, cracks, breaks, punctures, fraying, or other signs of damage or wear.
- (4) Inspect metal tubing for cracks, breaks, wear or corrosion leaks, bends which could greatly reduce effective oil flow, and other damage.

##### b. Replacement.

- (1) Remove any clamps which may hold the lines to the body or engine.
- (2) Replace any lines or fittings as necessary.

#### 4-63. Oil Reservoir

a. *General.* The hydraulic oil reservoir is located at the right side of the truck frame below the corner post. The purpose of the hydraulic reservoir is to hold sufficient oil for the entire hydraulic system. The reservoir is composed primarily of the dipstick and filler screen, breather assembly, suction hose and filter screen, and drain plug.

b. *Servicing.* Refer to figure 4-60.

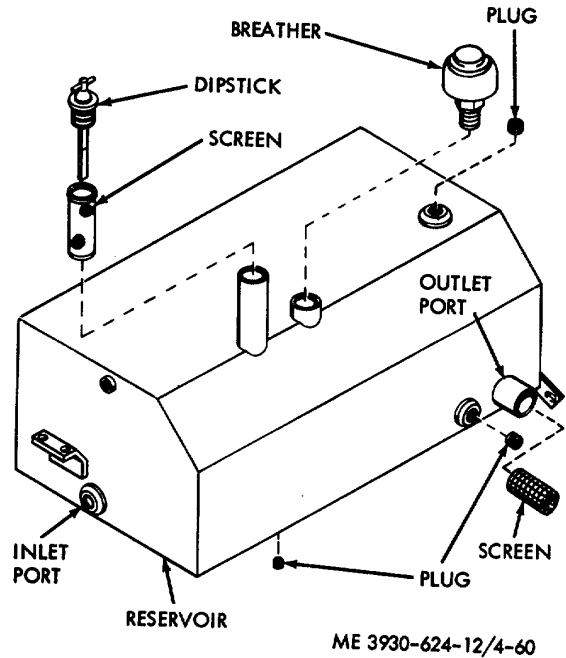

Figure 4-60. Hydraulic oil reservoir.

- (1) Disconnect the suction and return lines at the reservoir.
- (2) Remove the breather. Clean the outside and inside of the reservoir with a cleaning solvent.
- (3) Dry with compressed air.
- (4) Install the breather and suction and return lines.
- (5) Service the reservoir every 1000 hours.
- (6) Clean the filter screen at the suction hose with a cleaning solvent every 1000 hours.

#### 4-64. Oil Filter

##### a. Removal.

- (1) Remove the right-hand cowl.
- (2) Remove the nut and washer (fig. 4-61) from the hydraulic oil filter head.



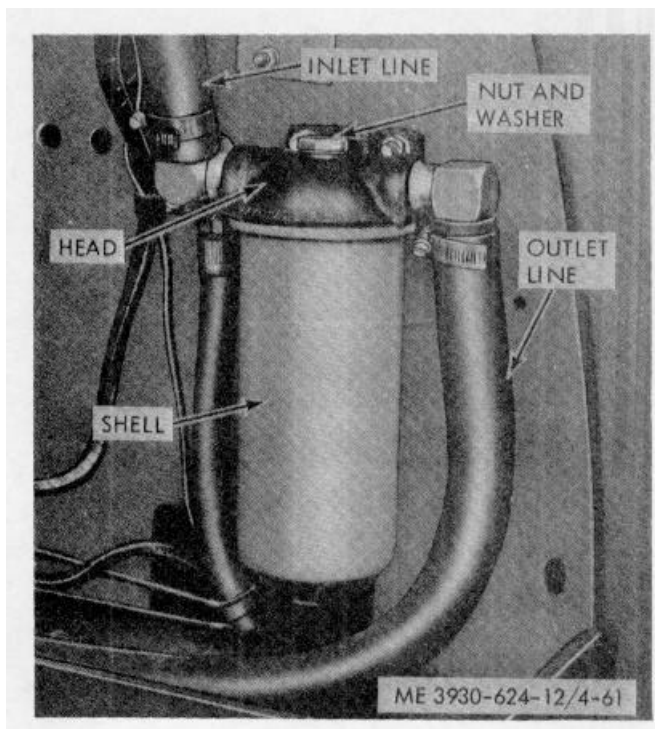

Figure 4-61. Hydraulic oil filter.

- (3) Separate the shell from the head and remove the gasket.
- (4) Remove the element from the shell.

b. *Servicing.* The filter element is a paper type and cannot be washed. If it is dirty, it must be replaced.

c. *Installation.*

- (1) Install the new filter element in the shell.
- (2) Position a new head gasket on the shell and install the shell on the head.
- (3) Install the washer and nut and tighten.
- (4) Operate the hydraulic system and check the filter for oil leaks.
- (5) Install the right-hand cowl.

#### 4-65. Oil Reservoir Breather

a. *Removal and Disassembly.* (fig. 4-60.)

- (1) Unscrew the breather from the tapped hole in the reservoir.
- (2) Plug the hole in the reservoir to prevent the entry of dirt or moisture.
- (3) Remove the screw and lockwasher from the top of the cover and lift the cover off. Remove the filter element.

b. *Service.*

- (1) Clean the filter element with compressed air.
- (2) Inspect the element for damage or hard deposits. If these conditions are present, replace the element.

### Section XVIII. MAINTENANCE OF THE BODY

#### 4-66. General

The truck has removable side panels and a removable seat and seat panel above the engine, all of which provide access to the engine compartment.

The floor plate and the toe plate are both removable to provide access to the torque converter, transmission, hydraulic oil reservoir, tilt cylinders, and pedal linkages. The adjustable operator's seat, which includes a backrest and cushion, is mounted on the seat deck

above the engine compartment. The overhead guard is provided over the operator's seat to protect him from falling loads.

#### 4-67. Radiator Grille

a. *Removal.* Remove the four capscrews, washers, lockwashers and nuts. Remove the grille (fig. 4-62).

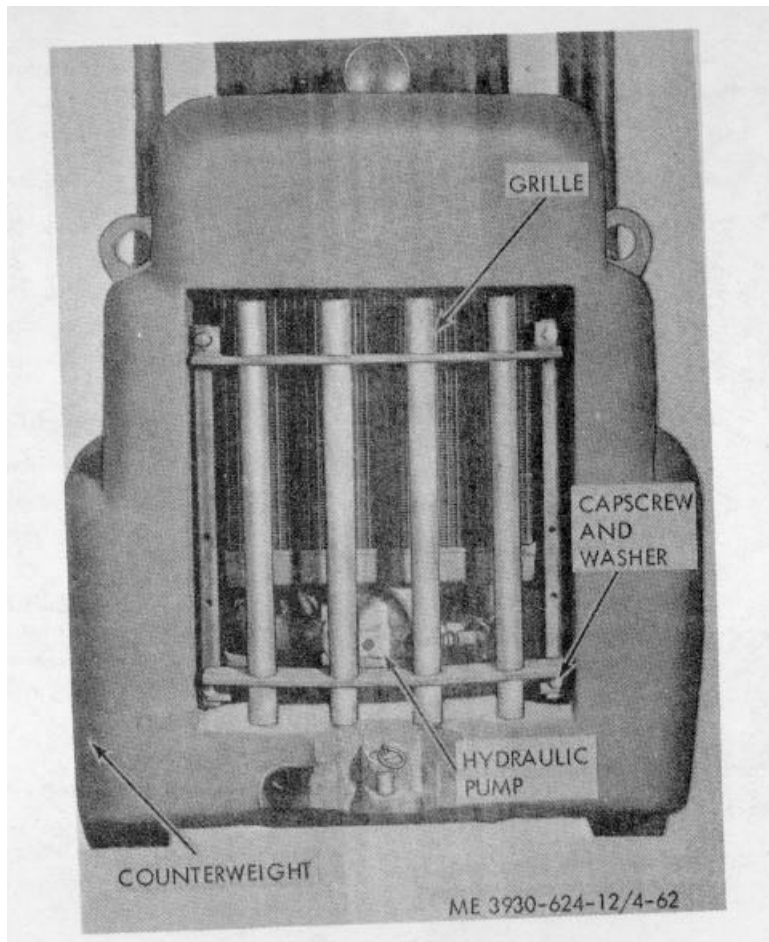
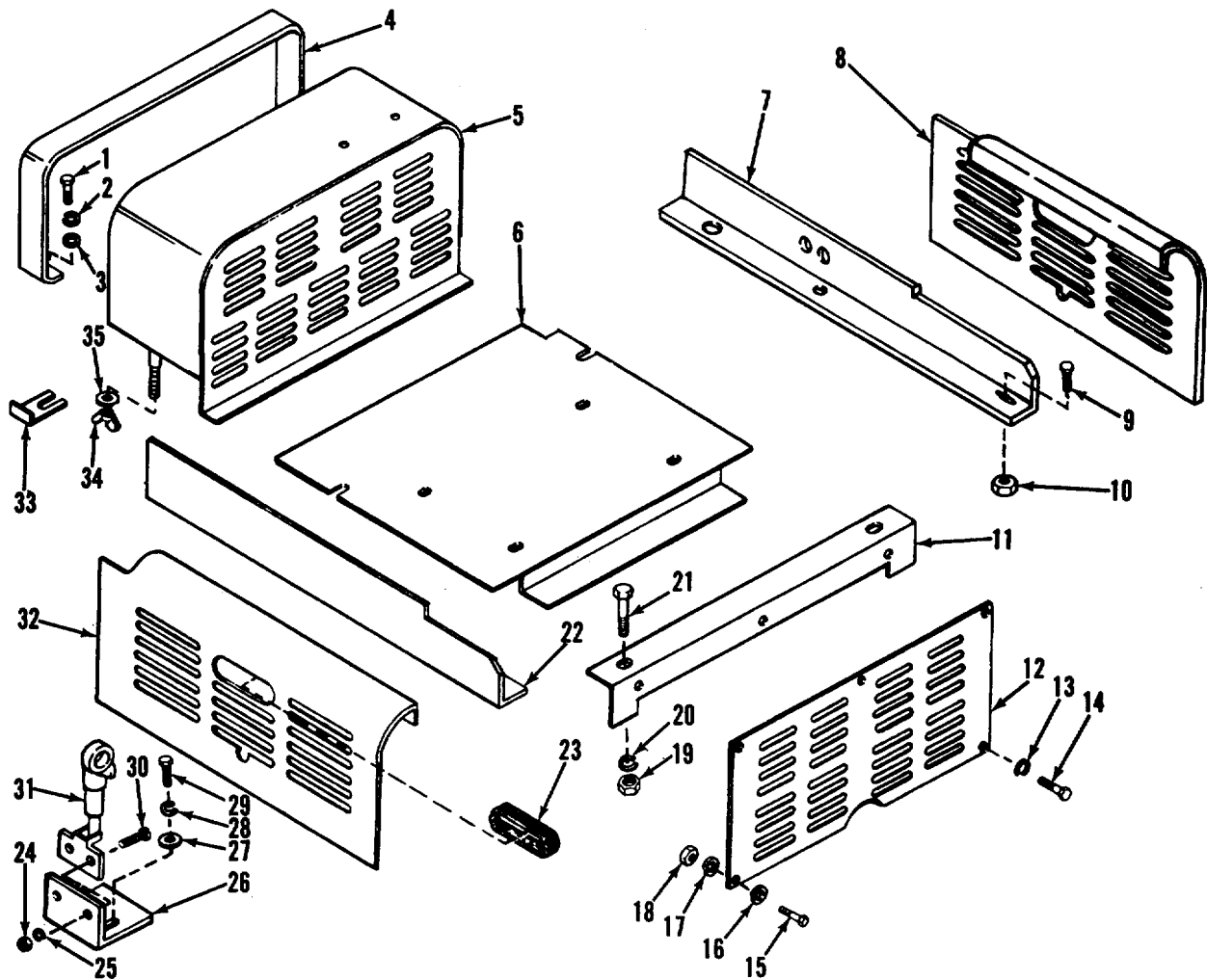

Figure 4-62. Grille removal

*b. Installation.* Install the radiator grille in the reverse order of removal.

*a. Removal.* Remove the five capscrews (14 and 15), lockwashers (13, 16, and 17) and two nuts (18). Remove the grille (12).

**4-68. Front Panel** (fig. 4-63)



ME 3930-624-12/4-63

- |                 |                |
|-----------------|----------------|
| 1. Capscrew     | 19. Nut        |
| 2. Lockwasher   | 20. Lockwasher |
| 3. Washer       | 21. Capscrew   |
| 4. Hood support | 22. Angle      |
| 5. Hood         | 23. Grommet    |
| 6. Deck         | 24. Nut        |
| 7. Angle        | 25. Lockwasher |
| 8. Panel        | 26. Bracket    |
| 9. Capscrew     | 27. Washer     |
| 10. Nut         | 28. Lockwasher |
| 11. Support     | 29. Capscrew   |
| 12. Grille      | 30. Screw      |
| 13. Lockwasher  | 31. Latch      |
| 14. Capscrew    | 32. Panel      |
| 15. Capscrew    | 33. Spacer     |
| 16. Lockwasher  | 34. Wingnut    |
| 17. Lockwasher  | 35. Washer     |
| 18. Nut         |                |

Figure 4-63. Hood, side panels, seat support and front grille.

b. *Installation.* Install the front grille in the reverse order of removal.

**4-69. Hood and Fenders**

a. *Removal.* Refer to figure 4-63.

(1) Remove the two wingnuts (134) and washers (135) securing the hood (5) to the frame. Remove the hood.

(2) Remove the four capscrew., lockwashers and spacers securing the right and left hand fenders. Be sure to note the size, quantity and location of the spacers. Remove the fenders.

b. *Installation.* Install the hood and fenders in the reverse order of removal.

**4-70. Counterweight**

a. *Removal.* (fig. 4-64).

**Note.** Loosen adjusting bolts top and side.

(1) Remove the retaining pin (12) securing the yoke pin (11). Drive the yoke pin out of the clevis (10).

(2) Remove the four capscrews (3 and 14) and nuts (5 and 15), and the lockwasher (14).

**Warning:** Use a hoist or winch of sufficient capacity to lift the counterweight, which weights approximately 3,125 pounds.

(3) Remove the towing shackle (1) securing the counterweight (6) to the frame (13). Remove the counterweight.

**Note.** Loosen adjusting bolts top and side.

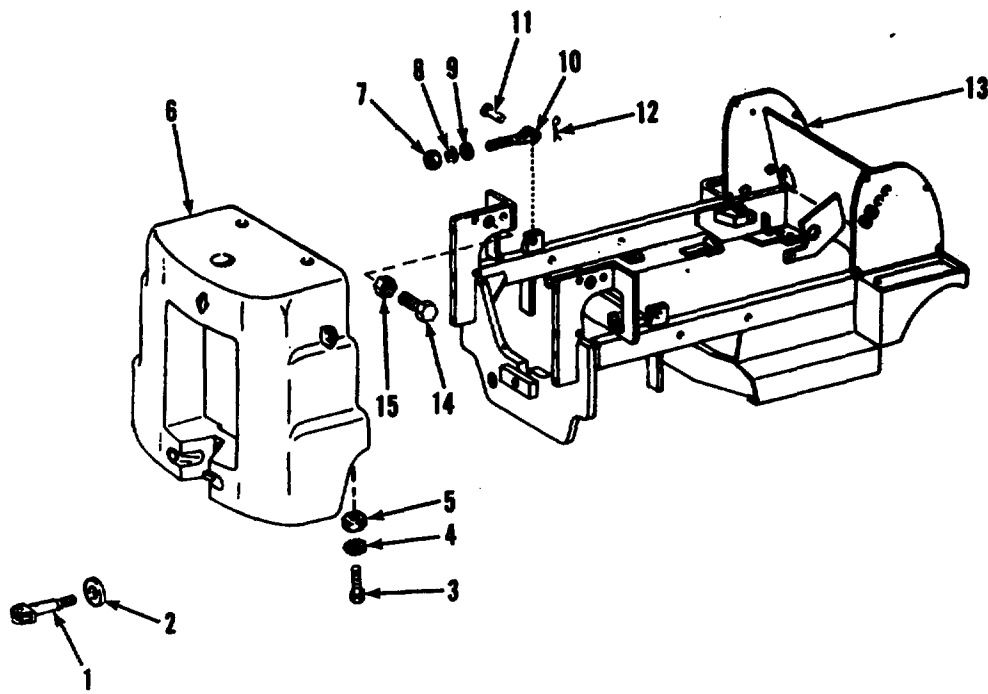

ME 3930-624-12/4-64

- |                   |                   |
|-------------------|-------------------|
| 1. Towing shackle | 9. Washer         |
| 2. Washer         | 10. Clevis        |
| 3. Capscrew       | 11. Yoke pin      |
| 4. lockwasher     | 12. Retaining pin |
| 5. Nut            | 13. Frame         |
| 6. Counterweight  | 14. Capscrew      |
| 7. Nut            | 15. Nut           |
| 8. Lockwasher     |                   |

Figure 4-64. Counterweight removal.

b. *Installation.* Install the counterweight in the reverse order of removal.

**4-71. Seat**

a. *Removal.* Remove four flanged nuts securing the seat assembly to the seat deck. Remove the seat assembly.

b. *Cleaning and Inspection.*

(1) Clean the seat cushion and the back cushion by washing with warm, soapy water.

(2) Clean the remaining parts with a cleaning solvent: dry thoroughly.

(3) Inspect the cushions for cracks, cuts,

collapsed springs, lumpy padding, or deteriorated covering. Replace damaged cushions.

(4) Inspect the seat frame for cracks, distortion, broken weldments, and other damage; replace damaged seat frame c. Installation. Install the seat assembly in the reverse order of removal.

**4-72. Floor Plate and Toe Plate**

a. Removal. (fig. 4-65).

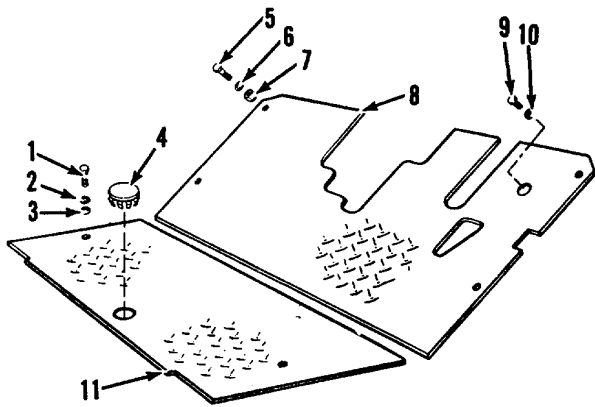

- |               |                 |
|---------------|-----------------|
| 1. Capscrew   | 7. Nut          |
| 2. Lockwasher | 8. Toe plate    |
| 3. Washer     | 9. Capscrew     |
| 4. Plug       | 10. Nut         |
| 5. Capscrew   | 11. Floor plate |
| 6. Washer     |                 |

Figure 4-65. Floor and toe plate.

(1) To remove floor plate, remove the two capscrews (1), washers (3), and lockwashers (2). Lift out the floor plate (11).

(2) Remove the four capscrews (5), washers (6), and nuts (7); remove the tow plate (8).

b. Installation. Install the floor and tow plate in the reverse order of removal.

**4-73. Overhead Guard**

a. Removal.

(1) Remove the pins securing the overhead guard to the frame (fig. 4-66).

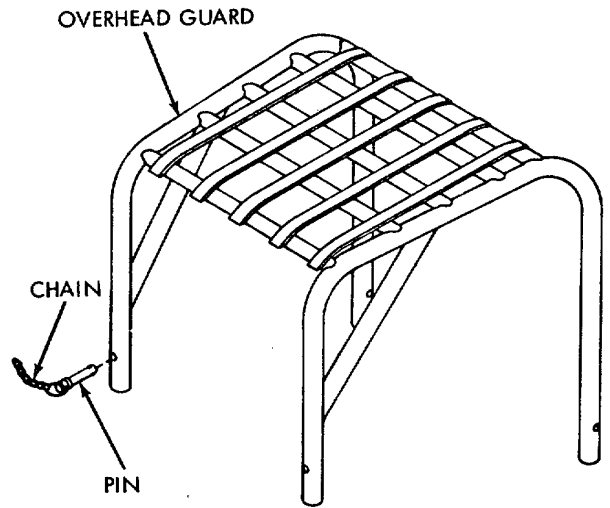

Figure 4-66. Overhead guard removal

(2) Attach a hoist to the overhead guard and lift it from the truck.

b. Cleaning and Inspection.

(1) Clean the overhead guard with warm, soapy water; flush with a water hose. Remove greasy, or gummy deposits with a cleaning solvent.

(2) Inspect for cracked or broken weldments, bent uprights, distortion, and other damage; replace a damaged guard.

c. Installation. Install the overhead guard in the reverse order of removal.

**4-74. Forks**

a. Removal.

(1) Position the fork carriage until the base of the fork just clears the floor.

(2) Release the lock pin (fig. 4-67) and slide the fork to a position over the cut-out in the lower carriage bar.

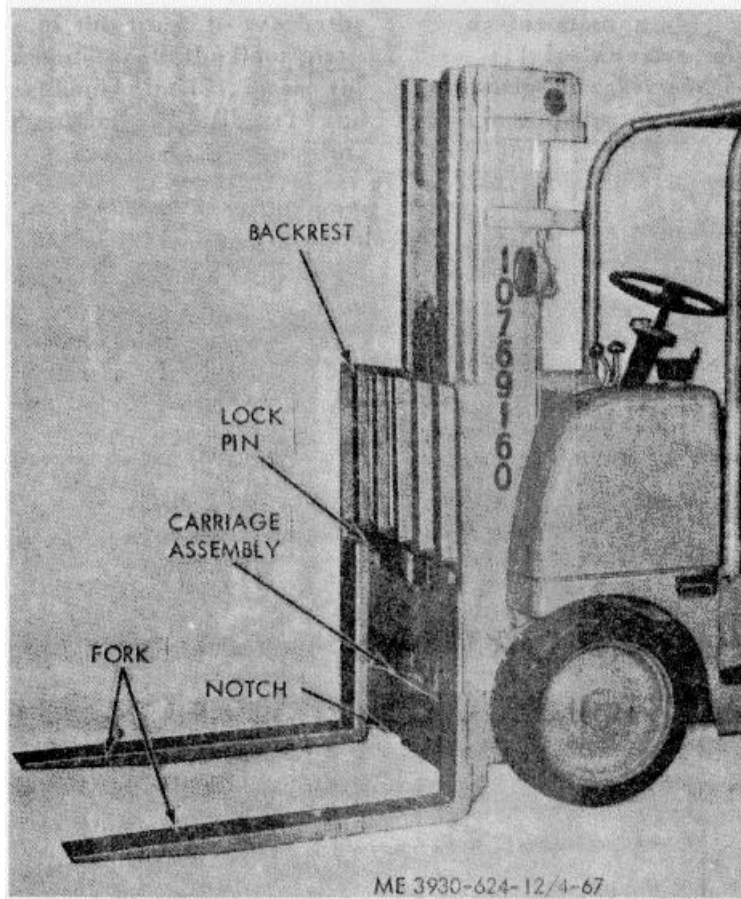

Figure 4-67. Fork removal.

(3) Tilt the lower portion of the fork forward and up, releasing the lower hanger from the lower carriage bar.

(4) Lift the fork up off the upper carriage bar.

*b. Inspection.*

(1) Inspect the fork and locking mechanism for signs of wear or damage.

(2) If the locking mechanism is worn or damaged, remove and replace it.

(3) Replace damaged or cracked forks.

*c. Installation.* The forks are installed by reversing the removal procedure.

*d. Adjustment.* The forks should always be adjusted sidewise on the carriage to obtain the maximum balance in proportion to the load. To change the fork location, pull up on the latch and move the fork right or left to the proper location and allow the fork lock pin to seat in a notch nearest the fork setting required.

## MATERIAL USED IN CONJUNCTION WITH THE TRUCK

**5-1. General**

This section contains instructions for operating the portable fire extinguisher (fig. 5-1) that is supplied with the truck. The dry chemical type fire extinguisher is suitable for use on all types of fire and is effective in areas where ambient temperature is 250°F and above. The fire extinguisher is a 2½ pound, stored pressure, lever operated extinguisher.

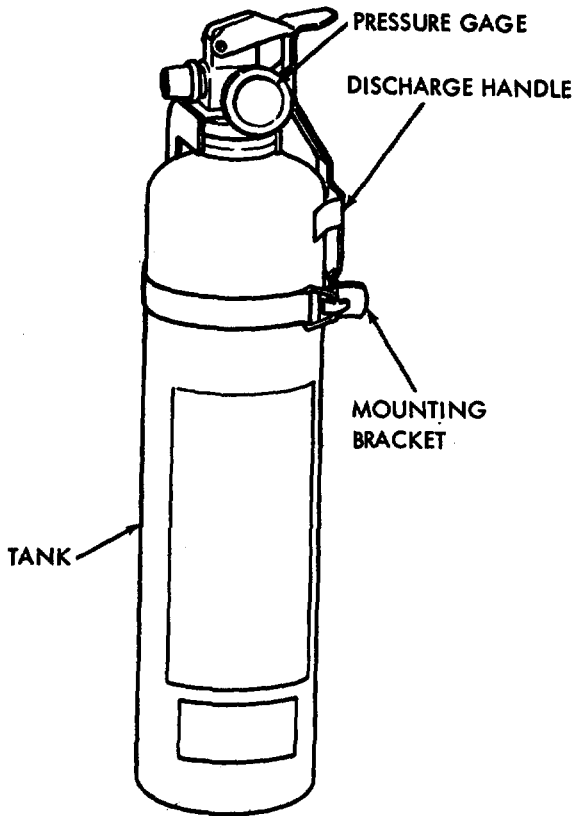

ME 3930-624-12/5-1

Figure 5-1. Fire extinguisher.

**5-2. Operating Extinguisher**

- a. Disconnect the clamp that secures the extinguisher to its mounting bracket, swing the clamp open, and remove the extinguisher.
- b. Hold the extinguisher upright and raise the locking handle to break the seal.
- c. Aim the nozzle at the base of the fire and depress the small operating lever with the thumb.
- d. Direct the discharge at the base of the fire with a side-to-side sweeping motion.

**Note.** This fire extinguisher can be used on flammable liquid and electrical fires.

**5-3. Maintenance**

- a. Check the fire extinguisher thoroughly to assure that it is in good condition and ready for operation.
- b. Check that the discharge nozzle is not dented or obstructed.
- c. Check the pressure gage to assure that it is at or above the FULL mark.
- d. If the pressure gage indicates less than full, the extinguisher must be replaced.

**Warning:** Do not attempt to recharge the extinguisher. It must be recharged by replacing with a new, factory charged cylinder.

## APPENDIX A

### REFERENCES

---

- A-1. Fire Protection**  
TB 5-4200-200-10  
Hand Portable Fire Extinguishers Approved for Army Users
- A-2. Lubrication**  
C9100IL  
LO 10-3930-624-12  
Fuels, Lubricants, Oils and Waxes  
Lubrication Order
- A-3. Painting**  
TM 9-213  
Painting Instructions for Field Use
- A-4. Radio Suppression**  
TM 11-483  
Radio Interference Suppression
- A-5. Maintenance**  
TB 750-651  
TM 38-750  
TM 10-3930-624-35P  
TM 10-3930-624-20P  
TM 9-6140-200-15  
Use of Antifreeze Solutions and Cleaning Compounds in Engine Cooling Systems  
The Army Maintenance Management System  
DS, GS, and Depot Maintenance Manual  
Organizational Maintenance Repair Parts Manual  
Operation and Organizational Field and Depot Maintenance Storage Batteries, Lead Acid Type
- A-6. Shipment and Storage**  
TB 740-93-2  
TM 740-90-1  
Preservation of USAMEC Mechanical Equipment for shipment and Storage  
Administrative Storage of Equipment
- A-7. Destruction of Army Materiel to Prevent Enemy Use**  
TM 750-244-3  
Procedures for Destruction of Equipment to Prevent Enemy Use (Mobility Equipment Command)



**APPENDIX B  
BASIC ISSUE ITEMS LIST**

**Section I. INTRODUCTION**

**B-1. Scope**

This appendix lists items which accompany the forklift truck or are required for installation, operation, or operator's maintenance.

**B-2. General**

This Basic Issue Items List is divided into the following sections:

*a. Basic Issue Items-Section II.* A list of items which accompany the forklift truck and are required by the operator/crew for installation, operation, or maintenance.

*b. Maintenance and Operating Supplies--Section III.* A listing of maintenance and operating supplies required for initial operation.

**B-3. Explanation of Columns**

The following provides an explanation of columns in the tabular list of Basic Issue Items, section II.

*a. Source, Maintenance, and Recoverability Codes (SMR):* (1) Source code indicates the source for the listed item. Source codes are:

<i>Code</i>	<i>Explanation</i>
P	Repair parts which are stocked in or supplied from the GSA/ DSA, or Army supply system and authorized for use at indicated maintenance categories.
M	Repair parts which are not procured or stocked, but are to be manufactured in indicated maintenance levels.
A	Assemblies which are not procured or stocked as such, but are made up of two or more units. Such component units carry individual stock numbers and descriptions, are procured and s stocked separately and can be assembled to form the required assembly at indicated maintenance categories.
X	Parts and assemblies which are not procured or stocked and the mortality of which normally is below that of the applicable end item or component. The failure of such part or assembly should result in retirement of the end item from the supply system.
X1	Repair parts which are not procured or stocked. The requirement for such items will be filled by use of the next higher assembly or component.
X2	Repair parts which are not stocked. The indicated maintenance category requiring such repair parts will attempt to obtain them through cannibalization. Where such repair parts are not obtainable through cannibalization,

<i>Code</i>	<i>Explanation</i>
	requirements will be requisitioned, with accompanying justification through normal supply channels.
G	Major assemblies that are procured with PEMA funds for initial issue only as exchange assemblies at DSU and GSU level. These assemblies will not be stocked above GS and DS level or returned to depot supply level. (2) Maintenance code indicates the lowest category of maintenance authorized to install the listed item. The maintenance level code is:
<i>Code</i>	<i>Explanation</i>
C	Operator / crew (3) Recoverability code indicates whether unserviceable items should be returned for recovery or salvage. Items not coded are expendable. Recoverability codes are:

<i>Code</i>	<i>Explanation</i>
R	Repair parts (assemblies and components) which are considered economically repairable at direct and general support maintenance levels. When the maintenance capability to repair these items does not exist, they are normally disposed of at the GS level. When supply considerations dictate, some of these repair parts may be listed for automatic return to supply for depot level repair as set forth in AR 710-50. When so listed, they will be replaced by supply on an exchange basis.
S	Repair parts and assemblies which are economically repairable at DSU and GSU activities and which normally are furnished by supply on an exchange basis. When items are determined by a GSU to be uneconomically repairable they will be evacuated to a depot for evaluation and analysis before final disposition.
T	High dollar value recoverable repair parts which are subject to special handling and are issued on an exchange basis. Such repair parts normally are repaired or overhauled at depot maintenance activities.
U	Repair parts specifically selected for salvage by reclamation units because of precious metal content, critical materials, or high dollar value reusable casings or castings.
	<i>b. Federal Stock Number.</i> This column indicates the Federal stock number assigned to the item and will be used for requisitioning purposes.

c. *Description*. This column indicates the Federal item name and any additional description of the item required. The abbreviation "w/e", when used as a part of the nomenclature, indicates the Federal stock number, includes all armament, equipment, accessories, and repair parts issued with the item. A part number or other reference number is followed by the applicable five-digit Federal supply code for manufacturers in parenthesis. Repair parts quantities included in kits, sets, and assemblies are shown in front of the repair part name.

d. *Unit of Measure (U/M)*. A two-character alphabetic abbreviation indicating the amount or quantity of the item upon which the allowances are based, e.g., ft, ea, pr, etc.

e. *Quantity Incorporated in Unit*. This column indicates the quantity of the item used in the assembly group. A "V" appearing in this column in lieu of a quantity indicates that a definite quantity cannot be indicated (e.g. shims, spacers, etc.).

f. *Quantity Furnished With Equipment*. This column indicates the quantity of an item furnished with the equipment.

g. *Illustration*. This column is divided as follows:

(1) Figure number. Indicates the figure number of the illustration in which the item is shown.

(2) Item number. Indicates the callout number used to reference the item in the illustration.

**B-4. Explanation of Columns in the Tabular List of Maintenance and Operating Supplies-Section III.**

a. *Component Application*. This column identifies the component application of each maintenance or operating supply item.

b. *Federal Stock Number*. This column indicates the Federal Stock number assigned to the item and will be used for requisitioning purposes.

c. *Description*. This column indicates the item name and brief description.

d. *Quantity Required for Initial Operation*. This column indicates the quantity of each maintenance or operating supply item required for initial Operation of the equipment.

e. *Quantity Required for 8-Hours Operation*. This column indicates the estimated quantities required for an average 8-hours of operation.

f. *Notes*. This column indicates informative notes keyed to data appearing in a preceding column.

**Section II. BASIC ISSUE ITEMS**

(1) SMR code	(2) Federal number	(3) Description  Ref No. & mfr. Code Usable on code		(4) Unit of meas	(5) Qty inc in unit	(6) Qty furn with equip	(7) Illustration	
							(A) Fig. No.	(B) Item No.
PC	7510-889-3494	Group 01 Accessories		ea		1		
		BINDER, Loose-leaf						
		CASE, Maintenance and Operation Manual						
PC	7520-559-9618	EXTINGUISHER, Fire 2 ½ lb. Fed. Spec O-E95		ea		1		
PC	4210-889-2221	Group 02 Publications		ea		1		
		Army Technical Manual TM 10-3930-624-12						
		Army Lubrication Order LO 10-3930-(24-12					ea	

**Section III. MAINTENANCE AND OPERATING SUPPLIES**

(1) Component application	(2) Federal stock number	(3) Description	(4) Quantity required f initial operation	(5) Quantity required f 8 hrs operation	(6) Notes
Air Cleaner	9150-265-9435(2) 9150-265-9428(2) 9150-242-7603(2)	OIL, LUBRICATING: 5-gal drum as follows: OE-30 OE-10 OES	½ pt ½ pt ½ Pt	(3) (3) (3)	(1) Includes quantity of oil to fill engine oil system as follows:  6 qts Engine crankcase 1 qt Oil filter
Crankcase	.....	OIL, LUBRICATING (4) OE-30 OE-10 OES	7qt (1) 7qt (1) 7qt (1)	(3) (3) (3)	(2) See C9100-IL for additional data and requisitioning procedures.) (3) 1 See current LO for grade. ap* plication and replenishment intervals.
Grease Points	.....	GREASE, AUTOMOTIVE AND AR-TILLERY: 5-lb can as follows: GAA	cleaner. 5 lb	(3)	(4) Use oil as prescribed for air
Hydraulic Brakes	9150-190-0905(2)	BRAKE FLUID, AUTOMOTIVE: 1-gal can as follows: HBA	5/16 qt	(3)	(5) Tank capacity. (6) Use oil as prescribed for hydraulic reservoir.
Hydraulic Reservoir	9150-231-9071(2)	OIL, LUBRICATING, ENGINE: 55-gal drum as follows: OE-10 OES	38 qt 38 qt	(3) (3)	
Oil Can Points	9150-265;9429(21) 9150-242-7604121	OIL, LUBRICATING (4) OE-30 OE-10			
Radiator	6850-644-1409 6850-174-1806	WATER ANTIFREEZE: 55-gal drum as follows: ANTIFREEZE: Ethylene glycol ANTIFREEZE: Compound arctic	16 qts  9 qts  16 qts		
Tank, Fuel	9130-160-1818(2) 9130.160-1830(2)	FUEL, GASOLINE: automotive; Bulk as follows: 91A 91C	8 3/4 gal 8 3/4 gal	(5) (5)	
Transmission, Torque Converter	OIL, LUBRICATING (6)	OE-10 OES	11 qts 11 qts	(3) (3)	
Differential	9150-577-5844 9150-257-5440	OIL, GEAR: GO GOS (Sub 0)	5 gal. can 5 pts 5 pts	(3) (3)	

## APPENDIX C

### MAINTENANCE ALLOCATION CHART

#### Section I. INTRODUCTION

##### C-1. General

a. This section provides a general explanation of all maintenance and repair functions authorized at various maintenance levels.

b. Section II designates overall responsibility for the performance of maintenance functions on the identified end item or component. The implementation of the maintenance functions upon the end item or component will be consistent with the assigned maintenance functions.

c. Section III is not applicable.

d. Section IV is not applicable.

##### C-2. Explanation of Columns in Section II

a. *Group Number, Column (1).* The assembly group is a numerical group assigned to each assembly in a top down breakdown sequence. The applicable assembly groups are listed on the MAC (Maintenance Allocation Chart) in disassembly sequence beginning with the first assembly removed in a top down disassembly sequence.

b. *Assembly Group, Column (2).* This column contains a brief description of the components of each assembly group.

c. *Maintenance Functions, Column (3).* This column lists the various maintenance functions (A through K) and indicates the lowest maintenance category authorized to perform these functions. The symbol designations for the various maintenance categories are as follows:

C--Operator or crew

O--Organizational maintenance

F--Direct support maintenance

H--General support maintenance

D--Depot maintenance

The maintenance functions are defined as follows:

**A--Inspect:** To determine serviceability of an item by comparing its physical, mechanical, and electrical characteristics with established standards.

**B--Test:** To verify serviceability and to detect electrical or mechanical failure by use of test equipment.

**C--Service:** To clean, to preserve, to charge, and to add fuel, lubricants, cooling agents, and air. If it is desired that elements such as painting and lubricating, be defined separately, they may be so listed.

**D--Adjust:** To rectify to the extent necessary to bring into proper operating range.

**E--Align:** To adjust specified variable elements of an item to bring to optimum performance.

**F--Calibrate:** To determine the corrections to be made in the readings of instruments or test equipment used in precise measurement. Consists of the comparison of two instruments, one of which is a certified standard of known accuracy, to detect and adjust any discrepancy in the accuracy of the instrument being compared with the certified standard.

**G--Install:** To set up for use in an operational environment such as an emplacement, site, or vehicle.

**H--Replace:** To replace unserviceable items with serviceable like items.

**I--Repair:** Those maintenance operations necessary to restore an item to serviceable condition through correction of material damage or a specific failure. Repair may be accomplished at each category of maintenance.

**J--Overhaul:** Normally, the highest degree of maintenance performed by the Army in order to minimize time work in process is consistent with quality and economy of operation. It consists of that maintenance necessary to restore an item to completely serviceable condition as prescribed by maintenance standards in technical publications for each item of equipment. Overhaul normally does not return an item to like new, zero mileage, or zero hour condition.

**K--Rebuild:** The highest degree of materiel maintenance. It consists of restoring equipment as nearly as possible to new condition in accordance with original manufacturing standards. Rebuild is performed only when required by operational considerations or other paramount factors and then only at the depot maintenance category. Rebuild reduces to zero the hours or miles the equipment, or component thereof, has been in use.

**d. Tools and Equipment, Column (4).** This column is provided for referencing by code the special tools and test equipment, (sec. III) required to perform the maintenance functions (sec. II).

e. *Remarks, Column (5).* This column is provided to the maintenance functions. for referencing by code the remarks (sec. IV) pertinent

**SECTION II. MAINTENANCE ALLOCATION CHART**

(1) Group No.	(2) Functional Group	(3) Maintenance functions										(4) Tools and equipment	(5) Remarks					
		A	B	C	D	E	F	G	H	I	J			K				
		Inspect	Test	Service	Adjust	Align	Calibrate	Install	Replace	Repair	Overhaul			Rebuild				
01	Engine																	
	Engine assembly.....	O	O	C	O				F	O		H				D		
	Cylinder block.....	H											D					
	Cylinder head.....								F	F								
	Crankshaft.....								H	D								
	Flywheel assembly.....								F	F								
	Engine valves.....				O				F	H								
	Timing gears.....	F							F									
	Oil filter.....			O					O									
	Oil pump.....	F							F									
	Manifold.....	O							O									
02	Fuel System																	
	Carburetor.....				O				O	F								
	Fuel pump.....		O	O					O									
	Fuel filter.....			O					O									
	Air cleaner.....			C					O									
	PCV valve.....			O					O									
	Fuel tank.....	O		C						H								
	Governor.....				O				F	F								
	Accelerator pedal & linkage.....				O				O									
03	Exhaust System																	
	Muffler and pipes.....	O							O									
04	Cooling System																	
	Radiator.....		F	C					O	H								
	Thermostat.....		O						O									
	Belt.....				O				O									
	Water pump.....		O						O									
05	Electrical System																	
	Alternator.....		O						O	F								
	Regulator, voltage.....		O						O									
	Starting motor.....		O						O	F								
	Distributor.....				O				O	O								
	Spark plugs.....				O				O									
	Ignition coil.....		O						O									
	Battery.....	O	O	C					O									
	Battery cables.....			O					O									
	Instrument panel and instruments.....	O							O									
06	Transmission																	
	Oil filter.....			O					O									
	Torque converter.....			O					F									
	Transmission assembly.....		F	C					F	F	H							
	Control valve.....		F						F	F								
07	Propeller Shafts																	
	Propeller shafts.....			O					O									
08	Front Axle (Drive)																	
	Drive axle ends.....								F	H								
	Differential.....								F	H								
09	Rear Axle (Steering)																	
	Rear axle assembly.....				F				F	F								
10	Wheels																	
	Wheel assembly.....								O	H								
	Tires.....	O							H									
11	Brakes																	
	Hand brake shoe.....				O				O									
	Hand brake lever.....				O				O									

**SECTION II. MAINTENANCE ALLOCATION CHART**

(1) Group No.	(2) Functional Group	(3) Maintenance functions											(4) Tools and equipment	(5) Remarks			
		A	B	C	D	E	F	G	H	I	J	K					
		Inspect	Test	Service	Adjust	Align	Calibrate	Install	Replace	Repair	Overhaul	Rebuild					
12	Service brake shoes.....				O				O	F							
	Wheel cylinders.....								O	F							
	Master cylinder.....				O				O	F							
	Brake pedal and linkage.....				O				F								
	Steering																
13	Tie rod.....				O				O	O							
	Steering gear assembly.....				F				F	H							
	Hydraulic cylinder.....				O				O	F							
	Hydraulic Lift Components																
	Hydraulic pump.....		F						F	F							
	Control valve.....								F	F							
	Tilt cylinder.....				O				F	F							
	Lift cylinder.....								F	F							
	Mast assembly.....								F	F							
	Carriage assembly.....								F	F							
Lines and fittings.....	O								O								
Oil filter.....			O						O								
Oil tank.....			O						F								
Tank breather.....			O						O								
Control levers and linkage.....				O					F								

# INDEX

	Paragraph	Page		Paragraph	Page
<b>A</b>					
Accelerator pedal and linkage:			Brakes:		
Cleaning and inspection .....	4-24	4-18	Brake lines .....	4-51	4-42
Reassembly and installation .....	4-24	4-18	General .....	4-49	4-40
Removal and disassembly .....	4-24	4-18	Master cylinder .....	4-52	4-43
Adjustment:			Parking brake handle and linkage .....	4-50	4-40
Carburetor .....	4-19	4-14	Service brake pedal linkage		
Fan and alternator belt .....	4-31	4-24	adjustment .....	4-53	4-53
Governor .....	4-22	4-16	Service brakes .....	4-51	4-42
Parking brake linkage .....	4-50	4-40			
Service brake pedal linkage .....	4-53	4-43	<b>C</b>		
Tie rods .....	4-58	4-45	Capacities .....	1-6	1-2
Valve .....	4-15	4-9	Carburetor:		
Air cleaner:			Adjustment .....	4-19	4-14
Cleaning and inspection .....	4-25	4-20	Installation .....	4-19	4-14
Reassembly and installation .....	4-25	4-20	Removal .....	4-19	4-14
Removal and disassembly .....	4-25	4-20	Cleaning:		
Service .....	4-25	4-20	Battery .....	4-39	4-33
Alternator:			Hydraulic oil tank and filter .....	4-63	4-48
Installation .....	4-33	4-25	Radiator .....	4-28	4-22
Removal .....	4-33	4-25	Cleaning and inspection:		
Testing .....	4-33	4-25	Accelerator pedal and linkage .....	4-24	4-18
			Air cleaner .....	4-25	4-20
<b>B</b>			Battery .....	4-39	4-33
Battery:			Battery cables .....	4-39	4-33
Cleaning .....	4-39	4-33	Body hoods .....	4-69	4-52
Cleaning and inspection .....	4-39	4-33	Brake master cylinder and brake lines .....	4-52	4-43
Installation .....	4-39	4-33	Engine oil filter .....	4-17	4-12
Removal .....	4-39	4-33	Exhaust muffler and piping .....	4-26	4-21
Service .....	4-39	4-33	Fuel tank, fuel lines, and fittings .....	4-21	4-16
Testing .....	4-39	4-33	Ignition distributor .....	4-36	4-28
Battery cables:			Instrument panel .....	4-40	4-34
Cleaning and inspection .....	4-39	4-33	Intake and exhaust manifold .....	4-18	4-12
Installation .....	4-39	4-33	Lights .....	4-41	4-36
Removal .....	4-39	4-33	Overhead guard .....	4-73	4-53
Bearings, wheel .....	4-56	4-45	Parking brake handle and linkage .....	4-50	4-40
Belt, fan and alternator .....	4-31	4-24	Positive crankcase ventilation		
Body:			valve .....	4-16	4-10
Body panels .....	4-68	4-50	Seat assembly .....	4-71	4-52
Counterweight .....	4-70	4-52	Service brakes .....	4-51	4-42
Floor Plate .....	4-72	4-53	Spark plugs .....	4-37	4-32
Forks .....	4-74	4-53	Starting motor .....	4-35	4-28
General .....	4-66	4-49	Tie rods .....	4-58	4-45
Hoods .....	4-69	4-52	Transmission oil filter and lines .....	4-45	4-37
Overhead guard .....	4-73	4-53	Wheel bearings .....	4-56	4-45
Radiator grille .....	4-67	4-49	Compression test .....	4-15	4-9
Seat assembly .....	4-71	4-52	Controls and instruments .....	2-5	2-1
Toe plate .....	4-72	4-53	Coolant .....		
Body hoods:			Cooling system:		
Cleaning and inspection .....	4-69	4-52	Fan and alternator belt .....	4-31	4-24
Installation .....	4-69	4-52	General .....	4-27	4-22
Removal .....	4-69	4-52	Radiator .....	4-28	4-22
Brake lines:			Thermostat .....	4-29	4-23
Cleaning and inspection .....	4-51	4-42	Water pump and fan blade .....	4-30	4-24
Installation .....	4-51	4-42	Counterweight:		
Removal .....	4-51	4-42	Installation .....	4-70	4-52
Brake master cylinder:			Removal .....	4-70	4-52
Cleaning and inspection .....	4-52	4-43			
Installation .....	4-52	4-43	<b>D</b>		
Removal .....	4-52	4-43	Depositing load .....		
			Description:		
			Drive system .....	1-5	1-1

	Paragraph	Page		Paragraph	Page
<b>D-(cont.)</b>					
Engine.....	1-5	11	Removal.....	4-35	4-28
Hydraulic system.....	1-5	1-1	Exhaust muffler and piping:		
Mast and carriage.....	1-5	1-1	Cleaning and inspection.....	4-26	4-21
Parking brake system.....	1-5	1-1	Reassembly and installation.....	4-26	4-21
Service brake system.....	1-5	1-1	Removal and disassembly.....	4-26	4-21
Steering system.....	1-5	1-1			
Dimensions and weight.....	1-6	1-2	<b>F</b>		
Disassembly:			Fan and alternator belt:		
Accelerator pedal and linkage.....	4-24	4-18	Adjustment.....	4-31	4-24
Air cleaner.....	4-25	4-20	Replacement.....	4-31	4-24
Body panels.....	4-68	4-50	Fan blade:		
Engine oil filter.....	4-17	4-12	Cleaning and inspection.....	4-30	4-24
Exhaust muffler and piping.....	4-26	4-21	Installation.....	4-30	4-24
Fuel tank, fuel lines and fittings.....	421	4-16	Removal.....	4-30	4-24
Hydraulic filter.....	464	4-48	Filter, hydraulic oil:		
Hydraulic( oil reservoir.....	4-63	4-48	Installation.....	4-64	4-48
Instrument panel.....	440	4-34	Removal.....	4-64	4-48
Lights.....	4-41	4-36	Servicing.....	4-64	4-48
Positive crankcase ventilation valve.....	4-16	4-10	Filter service:		
Service brakes.....	4-51	4-42	Transmission oil filter.....	4-45	4-37
Tie rods.....	4-58	4-45	Fire extinguisher:		
Transmission oil filter and lines.....	4-45	4-37	General.....	5-1	5-1
Wheel bearings.....	4-56	445	Maintenance.....	5-3	5-1
Dismantling for movement.....	2-2	2-1	Operating extinguisher.....	5-2	5-1
Distributor:			Floor plates:		
Distributor point repair and			Installation.....	4-72	4-53
replacement.....	4-36	4-28	Removal.....	4-72	4-53
Draining hydraulic oil tank.....	4-63	4-48	Forklift truck:		
Drive system:			Tabulated data.....	1-6	1-2
Description.....	1-5	1-1	Forks:		
Driving truck.....	2-6	2-3	Installation.....	4-74	4-53
Driving with load.....	2-6	23	Removal.....	4-74	4-53
			Fuel filter:		
<b>E</b>			Installation.....	4-23	4-17
Electrical system:			Removal.....	4-23	4-17
Alternator.....	4-33	4-25	Servicing.....	4-23	4-17
Battery and cables.....	4-39	4-33	Fuel pump:		
General.....	4-32	4-25	Inspection.....	4-20	4-15
Horn.....	4-42	4-37	Installation.....	4-20	4-15
Horn relay.....	4-43	4-37	Removal.....	4-20	4-15
Ignition oil.....	4-38	4-33	Testing.....	4-20	4-15
Ignition distributor.....	4-36	4-28	Fuel system:		
Instrument panel.....	4-40	4-34	Accelerator controls.....	4-24	4-18
Lights 4.....	4-41	4-36	Air cleaner.....	4-25	4-20
Spark plugs.....	4-37	4-32	Carburetor.....	4-19	4-14
Starting motor.....	4-35	4-28	Fuel filter.....	4-23	4-17
Voltage regulator.....	4-34	4-26	Fuel pump.....	4-20	4-15
Engine:			Fuel tank.....	4-21	4-16
Coolant.....	3-12	3-4	Governor adjustment.....	4-22	4-16
Description.....	1-5	1-1	Positive crankcase ventilation valve.....	4-16	4-10
General.....	1-5	1-1	Fuel tank:		
Intake and exhaust manifold.....	4-18	4-12	General.....	4-21	4-16
Oil filter.....	4-17	4-12	Installation.....	4-21	4-16
Valve adjustment.....	4-15	4-9	Removal.....	4-21	4-16
Engine alternator:					
Tabulated data.....	433	4-25	<b>G</b>		
Engine oil filter:			Governor:		
Cleaning and inspection.....	4-17	4-12	Adjustment.....	4-22	4-16
Disassembly.....	4-17	4-12			
Reassembly.....	4-17	4-12	<b>H</b>		
Service.....	4-17	4-12	Headlights.....	4-41	4-36
Engine starter:			Hydraulic lines and fittings:		
Cleaning and inspection.....	4-35	4-28	Inspection.....	4-62	4-48
Installation.....	4-35	4-28	Replacement.....	4-62	4-48
			Hydraulic oil filter:		
			Installation.....	4-64	4-48



	Paragraph	Page
<b>H (cont.)</b>		
Removal .....	4-64	4-48
Servicing .....	4-64	4-48
Hydraulic oil tank:		
Cleaning .....	4-63	4-48
Disassembly .....	4-63	4-48
Draining tank .....	4-63	4-48
Reassembly .....	4-63	4-48
Hydraulic reservoir breather:		
Reassembly and installation .....	4-65	4-49
Removal and disassembly .....	4-65	4-49
Service .....	4-65	4-49
Hydraulic system:		
Description .....	1-5	1-1
General .....	4-60	4-47
Hydraulic lines and fittings .....	4-62	4-48
Hydraulic oil filter .....	4-64	4-48
Hydraulic oil reservoir .....	4-63	4-48
Hydraulic reservoir breather .....	4-65	4-49
Tilt cylinder adjustment .....	4-61	4-47
<b>I</b>		
Identification .....	1-6	1-2
Ignition coil:		
Installation .....	4-38	4-33
Removal .....	4-38	4-33
Testing .....	4-38	4-33
Ignition distributor:		
Cleaning and inspection .....	4-36	4-28
Distributor point repair and replacement .....	4-36	4-28
Installation .....	4-36	4-28
Removal .....	4-36	4-28
Ignition timing test .....	4-36	4-28
Inspecting and servicing equipment .....	4-1	4-1
Inspection and testing:		
Radiator .....	4-28	4-22
Thermostat .....	4-29	4-23
Installation:		
Accelerator pedal and linkage .....	4-24	4-18
Air cleaner .....	4-25	4-20
Alternator .....	4-33	4-25
Battery .....	4-39	4-33
Battery cables .....	4-39	4-33
Body hoods E .....	4-69	4-52
Body panels .....	4-68	4-50
Brake master cylinder and brake lines .....	4-52	4-43
Carburetor .....	4-19	4-14
Counterweight .....	4-70	4-52
Exhaust muffler and piping .....	4-26	4-21
Fuel filter .....	4-23	4-17
Fuel plump .....	4-20	4-15
Fuel tank .....	4-21	4-16
Horn .....	4-42	4-37
Horn relay .....	4-43	4-37
Ignition coil .....	4-38	4-33
Ignition distributor .....	4-36	4-28
Instrument panel .....	4-40	4-34
intake and exhaust manifold .....	4-18	4-12
Lights .....	4-41	4-36
Overhead guard .....	4-73	4-53
Parking brake handle and linkage .....	4-50	4-40
Positive crankcase ventilation valve .....	4-16	4-10
Radiator .....	4-28	4-22
Radiator grille .....	4-67	4-49

	Paragraph	Page
Seat assembly .....	4-71	4-52
Service brakes .....	4-51	4-42
Spark plugs .....	4-37	4-32
Starting motor .....	4-35	4-28
Thermostat .....	429	4-23
Tie rods .....	4-58	4-45
Toe plate .....	4-72	4-53
Transmission oil filter and lines .....	4-45	4-37
Voltage regulator .....	4-34	4-26
Wheels and tires .....	4-54	4-44
Installation of separately packed components .....	4-2	4-1
Installation or setting up instructions .....	4-2	4-1
Instrument panel:		
Cleaning and inspection .....	4-40	4-34
Installation .....	4-40	4-34
Removal .....	4-40	4-34
Intake and exhaust manifold:		
Cleaning and inspection .....	4-18	4-12
Installation .....	4-18	4-12
Removal .....	4-18	4-12
Interference suppression components:		
General .....	4-11	4-8
Primary .....	4-12	4-9
Replacement .....	4-13	4-9
Secondary .....	4-12	4-9
Testing .....	4-14	4-9
Introduction:		
Forms and records .....	1-2	1-1
Scope .....	11	1-1
<b>L</b>		
Lamp replacement .....	4-41	4-36
Lights:		
Cleaning and inspection .....	4-41	4-36
Installation .....	4-41	4-36
Removal .....	4-41	4-36
Lubrication:		
Detailed lubrication information .....	4-7	4-2
General lubrication information .....	4-6	4-2
<b>M</b>		
Mast and carriage:		
Description .....	1-5	1-1
Master cylinder, brake .....	4-5	4-43
<b>O</b>		
Oil service:		
Engine .....	3-2	3-1
Transmission .....	3-2	3-1
Operation:		
In extreme cold .....	2-10	2-4
In extreme heat .....	2-11	2-5
In high altitudes .....	2-15	2-6
In rainy or humid areas .....	2-13	2-5
in salt water areas .....	2.14	2-5
In sandy or dusty areas .....	2-12	2-5
Under usual conditions .....	2-9	2-4
Operation under usual conditions:		
Depositing load .....	2-9	2-4
Driving truck .....	2-9	2-4
Driving with load .....	2-9	2-4
General .....	2-4	2-1
Picking up load .....	2-9	2-4
Starting .....	2-7	2-2
Stopping .....	2.8	2-2

## O (cont.)

	Paragraph	Page
Operator's maintenance:		
Air cleaner service .....	3-9	3-4
Engine coolant .....	3-12	3-4
Fuel supply .....	3-10	3-4
Overhead guard:		
Cleaning and inspection .....	4-73	4-53
Installation .....	4-73	4-53
Removal .....	4-73	4-53

## P

Packing, wheel bearing .....	4-56	4-45
Parking brake handle and linkage:		
Adjustment .....	4-50	4-40
Cleaning and inspection .....	4-50	4-40
Installation .....	4-50	4-40
Removal .....	4-50	4-40
Parking brake system:		
Description .....	1-5	1-1
Picking up load .....	2-11	2-5
Positive crankcase ventilation valve:		
Cleaning and inspection .....	4-16	4-10
Removal .....	4-16	4-10
Service .....	4-16	4-10
Preventive maintenance checks and services .....	4-2	4-2
Propeller shafts .....	4-46	4-40

## R

Radiator:		
Cleaning .....	4-28	4-22
Inspection and testing .....	4-28	4-22
Installation .....	4-28	4-22
Removal .....	4-28	4-22
Radiator grille:		
Installation .....	4-67	4-49
Removal .....	4-67	4-49
Radio interference suppression .....	4-11	4-8
Reassembly:		
Accelerator pedal and linkage .....	4-24	4-18
Air cleaner .....	4-25	4-20
Body hoods .....	4-69	4-52
Body panels .....	4-68	4-50
Engine oil filter .....	4-17	4-12
Exhaust muffler and piping .....	4-26	4-21
Fuel tanks, fuel lines, and fittings .....	4-21	4-16
Hydraulic oil tank and filter .....	4-63	4-48
Instrument panel .....	4-40	4-34
Lights .....	4-41	4-36
Positive crankcase ventilation valve .....	4-16	4-10
Service brakes .....	4-51	4-42
Tie rods .....	4-58	4-45
Transmission oil filter and 11 .....	4-45	4-37
Wheel bearings .....	4-56	4-45
Records and forms .....	1-2	1-1
Removal:		
Accelerator pedal and linkage .....	4-24	4-18
Air cleaner .....	4-25	4-20
Alternator .....	433	4-25
Battery .....	4-39	4-33
Battery cables .....	4-39	4-33
Body hoods .....	4-69	4-52
Body panels .....	4-68	4-50
Brake master cylinder and brake lines .....	4-52	4-43
Carburetor .....	4-19	4-14

	Paragraph	Page
Counterweight .....	4-70	4-52
Exhaust muffler and piping .....	4-26	4-21
Floor plates .....	4-72	4-53
Forks .....	4-74	4-53
Hydraulic lines and fittings .....	4-62	4-48
Ignition coil .....	4-38	4-33
Ignition distributor .....	4-36	4-28
Instrument panel .....	4-40	4-34
Intake and exhaust manifold .....	4-18	4-12
Lights .....	4-41	4-36
Overhead guard and floor plate .....	4-73	4-53
Parking brake handle and linkage .....	4-50	4-40
Positive crankcase ventilation valve .....	4-16	4-10
Radiator .....	4-28	4-22
Radiator grille .....	4-67	4-49
Seat assembly .....	4-71	4-52
Service brakes .....	4-51	4-42
Spark plugs .....	4-37	4-32
Starting motor .....	4-35	4-28
Thermostat .....	4-29	4-23
Tie rods .....	4-58	4-45
Toe plates .....	4-72	4-53
Transmission oil filter and lines .....	4-45	4-37
Voltage regulator .....	4-34	4-26
Wheel bearings .....	4-56	4-45
Wheels and tires .....	4-55	4-44
Replacement:		
Fan and alternator belt .....	4-31	4-24

## S

Scope .....	1-1	1-1
Seat assembly:		
Cleaning and inspection .....	4-71	4-52
Installation .....	4-71	4-52
Removal .....	4-71	4-52
Service:		
Air cleaner .....	3-8	3-4
Battery .....	4-39	4-33
Engine filter .....	4-17	4-12
Positive crankcase ventilation valve .....	4-16	4-10
Service brake system:		
Description .....	1-5	1-1
Service brakes:		
Cleaning and inspection .....	4-51	4-42
Reassembly and installation .....	4-51	4-42
Removal and disassembly .....	4-51	4-42
Service upon receipt of materiel:		
Inspecting and servicing equipment .....	4-1	4-1
Installation of separately packed components .....	4-2	4-1
Installation or setting up instructions .....	4-2	4-1
Unloading the equipment .....	4-2	4-1
Service:		
Fuel filter .....	4-23	4-17
Spark plugs:		
Cleaning and inspection .....	4-37	4-32
Installation .....	4-37	4-32
Removal .....	4-37	4-32
Starting .....	4-37	4-32
Starting motor:		
Cleaning and inspection .....	4-35	4-28
Installation .....	4-35	4-28
Removal .....	4-35	4-28
Testing .....	4-35	4-28

**S (cont.)**

Steering:		
General .....	4-57	4-45
Power steering cylinder .....	4-59	4-46
Tie rods .....	4-58	4-45
Steering system:		
Description .....	1-5	1-1
Stopping .....	2-8	2-3

**T**

Tabulated data:		
Alternator .....	4-33	4-25
Capacities .....	1-6	1-2
Engine .....	1.6	1-2
Forklift truck .....	1-6	1-2
Hydraulic Pump .....	1-6	1-2
Tires .....	1-6	1-2
Transmission .....	1.6	1-2
Voltage regulator .....	4-34	4-26
Testing:		
Alternator .....	4-33	4-25
Fuel pump .....	4-20	4-15
Ignition coil .....	4-38	4-33
Ignition timing test .....	4-36	4-28
Starting motor .....	4-35	4-28
Testing and adjustment:		
Voltage regulator .....	4-34	4-26
Thermostat:		
Inspection and testing .....	4-29	4-23
Installation .....	4-29	4-23
Removal .....	4-29	4-23
Tie Rods:		
Cleaning and inspection .....	4-58	4-45
Reassembly, installation, and adjustment .....	4-58	4-45
Removal and disassembly .....	4-58	4-45
Tires:		
Tabulated data .....	1-6	1-2
Toe plate:		
Installation .....	4-72	4-53

Removal .....	4-72	4-53
Tool and equipment .....	4-3	4-1
Transmission:		
General .....	4-44	4-37
Oil filter and lines .....	4-45	4-37
Oil service .....	4-45	4-37
Tabulated data .....	1-6	1-2
Transmission oil filter and lines:		
Cleaning and inspection .....	4-45	4-37
Filter service .....	4-45	4-37
Reassembly and installation .....	4-45	4-37
Removal and disassembly .....	4-45	4-37
Troubleshooting .....	4-10	4-2

**V**

Valve:		
Adjustment .....	4-15	4-9
Voltage regulator:		
Installation .....	4-34	4-26
Removal .....	4-34	4-26
Tabulated data .....	4-34	4-26
Testing and adjustment .....	4-34	4-26

**W**

Water pump:		
Cleaning and inspection .....	4-30	4-24
Reassembly and installation .....	4-30	4-24
Removal and disassembly .....	4-30	4-24
Wheel bearings:		
Cleaning and inspection .....	4-56	4-45
Packing .....	4-56	4-45
Reassembly .....	4-56	4-45
Removal and disassembly .....	4-56	4-45
Wheels and tires:		
Cleaning and inspection .....	4-55	4-44
General .....	4-54	4-44
Installation .....	4-55	4-44
Removal .....	4-55	4-44
Wheel bearings .....	4-56	4-45

By Order of the Secretary of the Army:

Official:

KENNETH G. WICKHAM,  
*Major General, United States Army,  
The Adjutant General.*

W. C. WESTMORELAND,  
*General, United States Army,  
Chief of Staff.*

Distribution:

To be distributed in accordance with DA Form 12-25, Section I. (qty rqr block no. 193) operators maintenance requirements for Truck. Fork Lift: Gasoline.

\*U.S. GOVERNMENT PRINTING OFFICE: 1985 461 421 21339

RECOMMENDED CHANGES TO EQUIPMENT TECHNICAL PUBLICATIONS



THEN... JOT DOWN THE DOPE ABOUT IT ON THIS FORM, CAREFULLY TEAR IT OUT, FOLD IT AND DROP IT IN THE MAIL!

**SOMETHING WRONG WITH THIS PUBLICATION?**

FROM: (PRINT YOUR UNIT'S COMPLETE ADDRESS)

DATE SENT

PUBLICATION NUMBER

PUBLICATION DATE

PUBLICATION TITLE

BE EXACT... PIN-POINT WHERE IT IS

IN THIS SPACE TELL WHAT IS WRONG AND WHAT SHOULD BE DONE ABOUT IT:

PAGE NO.	PARA-GRAPH	FIGURE NO.	TABLE NO.
----------	------------	------------	-----------

TEAR ALONG PERFORATED LINE

PRINTED NAME, GRADE OR TITLE, AND TELEPHONE NUMBER

SIGN HERE:

DA FORM 2028-2 JUL 79

PREVIOUS EDITIONS ARE OBSOLETE.

P.S.—IF YOUR OUTFIT WANTS TO KNOW ABOUT YOUR RECOMMENDATION MAKE A CARBON COPY OF THIS AND GIVE IT TO YOUR HEADQUARTERS.

